

CODE 4

**OECD STANDARD CODE
FOR THE OFFICIAL TESTING
OF PROTECTIVE STRUCTURES ON
AGRICULTURAL AND FORESTRY TRACTORS**

(STATIC TEST)

TABLE OF CONTENTS

1. DEFINITIONS	3
1.1 Agricultural and forestry tractors	3
1.2 Rolling Over Protective Structure (ROPS).....	3
1.3 Track.....	3
1.4 Wheelbase.....	4
1.5 Determination of seat index point; Seat location and adjustment for test	4
1.6 Clearance zone.....	4
1.7 Mass.....	6
1.8 Permissible measurement tolerances	6
1.9 Symbols	6
2. FIELD OF APPLICATION.....	7
3. RULES AND DIRECTIONS	7
3.1 General regulations.....	7
3.2 Apparatus.....	8
3.3 Test conditions.....	9
3.4 Sequence of tests	9
3.5 Horizontal loading tests from the rear, front and side	10
3.6 Crushing tests	11
3.7 Second longitudinal loading test.....	12
3.8 Conditions for acceptance	13
3.9 Extension to other tractor models.....	13
3.10 Labelling.....	15
3.11 Cold weather performance of protective structures.....	16
3.12 Seatbelt anchorage performance (optional).....	17
SPECIMEN TEST REPORT	37
1. SPECIFICATION OF TEST TRACTOR.....	37
2. SPECIFICATION OF PROTECTIVE STRUCTURE.....	38
3. TEST RESULTS	40
SPECIMEN TECHNICAL EXTENSION REPORT	43
1. SPECIFICATION OF TEST TRACTOR.....	43
2. SPECIFICATION OF PROTECTIVE STRUCTURE.....	45
3. TEST RESULTS (in case of a validation test)	47
SPECIMEN ADMINISTRATIVE EXTENSION REPORT.....	50
ANNEX I CLEARANCE ZONE REFERRED TO THE SEAT REFERENCE POINT	51
INTRODUCTION	52
1. DEFINITIONS	52
1.5 Determination of seat reference point; Seat location and adjustment for test	52
1.6 Clearance zone.....	53

CODE 4
OECD STANDARD CODE FOR THE OFFICIAL TESTING
OF PROTECTIVE STRUCTURES ON AGRICULTURAL AND FORESTRY TRACTORS
(STATIC TEST)

1. DEFINITIONS

1.1 *Agricultural and forestry tractors*

Self-propelled wheeled vehicles, having at least two axles, or with tracks, designed to carry out the following operations, primarily for agricultural and forestry purposes:

to pull trailers;

to carry, pull or propel agricultural and forestry tools or machinery and, where necessary, supply power to operate them with the tractor in motion or stationary.

1.2 *Rolling Over Protective Structure (ROPS)*

Roll-over protective structure (safety cab or frame), hereinafter called “protective structure”, means the structure on a tractor the essential purpose of which is to avoid or limit risks to the driver resulting from roll-over of the tractor during normal use.

The roll-over protective structure is characterized by the provision of space for a clearance zone large enough to protect the driver when seated either inside the envelope of the structure or within a space bounded by a series of straight lines from the outer edges of the structure to any part of the tractor that might come into contact with flat ground and that is capable of supporting the tractor in that position if the tractor overturns.

1.3 *Track*

1.3.1 Preliminary definition: median plane of the wheel or track

The median plane of the wheel or track is equidistant from the two planes containing the periphery of the rims or tracks at their outer edges.

1.3.2 Definition of track

The vertical plane through the wheel axis intersects its median plane along a straight line which meets the supporting surface at one point. If **A** and **B** are the two points thus defined for the wheels on the same axle of the tractor, then the track width is the distance between points **A** and **B**. The track may be thus defined for both front and rear wheels. Where there are twin wheels, the track is the distance between two planes each being the median plane of the pairs of wheels.

For tracklaying tractors, the track is the distance between the median planes of the tracks.

1.3.3 Additional definition: median plane of the tractor

Take the extreme positions of points **A** and **B** for the tractor rear axle, which gives the maximum possible value for the track. The vertical plane at right angles to the line **AB** at its centre point is the median plane of the tractor.

1.4 Wheelbase

The distance between the vertical planes passing through the two lines **AB** as defined above, one for the front wheels and one for the rear-wheels.

1.5 Determination of seat index point; Seat location and adjustment for test

1.5.1 Seat index point (SIP)¹

The seat index point shall be determined in accordance with ISO 5353:1995

1.5.2 Seat location and adjustment for test

1.5.2.1 where the seat position is adjustable, the seat must be adjusted to its rear uppermost position;

1.5.2.2 where the inclination of the backrest is adjustable, it must be adjusted to the mid position;

1.5.2.3 where the seat is equipped with suspension, the latter must be blocked at mid-travel, unless this is contrary to the instructions clearly laid down by the seat manufacturer;

1.5.2.4 where the position of the seat is adjustable only lengthwise and vertically, the longitudinal axis passing through the seat index point shall be parallel with the vertical longitudinal plane of the tractor passing through the centre of the steering wheel and not more than 100 mm from that plane.

1.6 Clearance zone

1.6.1 Reference plane

The clearance zone is illustrated in figures 4.9 to 4.11 and table 4.2. The zone is defined in relation to the reference plane and the seat index point (SIP). The reference plane is a vertical plane, generally longitudinal to the tractor and passing through the seat index point and the centre of the steering wheel. Normally the reference plane coincides with the longitudinal median plane of the tractor. This reference plane shall be assumed to move horizontally with the seat and steering wheel during loading but to remain perpendicular to the tractor or the floor of the roll-over protective structure. The clearance zone shall be defined on the basis of Sections 1.6.2 and 1.6.3.

1.6.2 Determination of the clearance zone for tractors with a non-reversible seat

The clearance zone for tractors with a non-reversible seat is defined in 1.6.2.1 to 1.6.2.10 below and is bounded by the following planes, the tractor being on a horizontal surface, the seat adjusted and located as

¹ For extension tests to test reports that originally used seat reference point (SRP), the required measurements shall be made with reference to SRP instead of SIP and the use of SRP shall be clearly indicated (see Annex 1).

specified in Sections 1.5.2.1 to 1.5.2.4², and the steering wheel, where adjustable, adjusted to the mid position for seated driving:

1.6.2.1 a horizontal plane **A₁ B₁ B₂ A₂**, (810 + a_v) mm above the seat index point (SIP) with line B₁B₂ located (a_h - 10) mm behind the SIP;

1.6.2.2 an inclined plane **G₁ G₂ I₂ I₁**, perpendicular to the reference plane, including both a point 150 mm behind line B₁B₂ and the rearmost point of the seat backrest;

1.6.2.3 a cylindrical surface **A₁ A₂ I₂ I₁** perpendicular to the reference plane, having a radius of 120 mm, tangential to the planes defined in 1.6.2.1 and 1.6.2.2 above;

1.6.2.4 a cylindrical surface **B₁ C₁ C₂ B₂**, perpendicular to the reference plane, having a radius of 900 mm extending forward for 400 mm and tangential to the plane defined in 1.6.2.1 above along line B₁B₂;

1.6.2.5 an inclined plane **C₁ D₁ D₂ C₂**, perpendicular to the reference plane, joining the surface defined in 1.6.2.4 above and passing 40 mm from the forward external edge of the steering wheel. In the case of a high steering wheel position, this plane extends forward from line B₁B₂ tangentially to the surface defined in 1.6.2.4 above;

1.6.2.6 a vertical plane **D₁ E₁ E₂ D₂** perpendicular to the reference plane 40 mm forward of the external edge of the steering wheel;

1.6.2.7 a horizontal plane **E₁ F₁ F₂ E₂** passing through a point (90 - a_v) mm below the seat index point (SIP);

1.6.2.8 a surface **G₁ F₁ F₂ G₂**, if necessary curved from the bottom limit of the plane defined in 1.6.2.2 above to the horizontal plane defined in 1.6.2.7 above, perpendicular to the reference plane, and in contact with the seat backrest throughout its length;

1.6.2.9 vertical planes **J₁ E₁ F₁ G₁ H₁** and **J₂ E₂ F₂ G₂ H₂**. These vertical planes shall extend upwards from plane **E₁ F₁ F₂ E₂** for 300 mm; the distances **E₁ E₀** and **E₂ E₀** shall be 250 mm;

1.6.2.10 parallel planes **A₁ B₁ C₁ D₁ J₁ H₁ I₁** and **A₂ B₂ C₂ D₂ J₂ H₂ I₂** inclined so that the plane upper edge of the plane on the side on which the force is applied is at least 100 mm from the vertical reference plane.

1.6.3 Determination of clearance zone for tractors with a reversible driver's position

For tractors with a reversible driver's position (reversible seat and steering wheel), the clearance zone is the envelope of the two clearance zones defined by the two different positions of the steering wheel and the seat. 1.6.4 Optional seats

1.6.4.1 In case of tractors that could be fitted with optional seats, the envelope comprising the seat index points of all options offered shall be used during the tests. The protective structure shall not enter the larger clearance zone which takes account of these different seat index points.

² Users are reminded that the seat index point is determined according to ISO 5353 and is a fixed point with respect to the tractor that does not move as the seat is adjusted away from the midposition.

1.6.4.2 In the case where a new seat option is offered after the test has been performed, a determination shall be made to see whether the clearance zone around the new SIP falls within the envelope previously established. If it does not, a new test must be performed.

1.7 Mass

1.7.1 Unballasted Mass

The mass of the tractor without ballasting devices and, in the case of tractors with pneumatic tyres, without liquid ballast in the tyres. The tractor shall be in running order with tanks, circuits and radiator full, protective structure with cladding and any track equipment or additional front wheel drive components required for normal use. The operator is not included.

1.7.2 Maximum Permissible Mass

The maximum mass of the tractor stated by the manufacturer to be technically permissible and declared on the vehicle's identification plate and/or in the Operator's Handbook;

1.7.3 Reference Mass

The mass selected by the manufacturer for calculation of the energy inputs and crushing forces to be used in the tests. Must not be less than the unballasted mass and must be sufficient to ensure the Mass Ratio does not exceed 1.75 (see Sections 1.7.4 and 2.1)."

1.7.4 Mass Ratio

The ratio of $\left(\frac{\text{Max. Permissible Mass}}{\text{Reference Mass}} \right)$ This must not be greater than 1.75.

1.8 Permissible measurement tolerances

Time	± 0.2 s
Distance	± 0.5 %
Force	± 1.0 %
Mass	± 0.5 %

1.9 Symbols

a_h	(mm)	Half of the horizontal seat adjustment
a_v	(mm)	Half of the vertical seat adjustment
D	(mm)	Deflection of the protective structure at the point of and in line with the load application
D'	(mm)	Deflection of the protective structure for the calculated energy required
E_{IS}	(J)	Energy input to be absorbed during side loading
E_{IL1}	(J)	Energy input to be absorbed during longitudinal loading
E_{IL2}	(J)	Energy input to be absorbed in case of a second longitudinal loading
F	(N)	Static load force
F_{max}	(N)	Maximum static load force occurring during loading, with the exception of the overload
F'	(N)	Force for the calculated energy required
M	(kg)	Reference mass used for calculating energy inputs and crushing forces

2. FIELD OF APPLICATION

2.1 This OECD Standard Code is applicable to tractors having at least two axles for pneumatic tyred wheels or having tracks instead of wheels and with an unballasted tractor mass not less than 600 kg. The Mass Ratio (*Maximum Permissible Mass / Reference Mass*) must not be greater than 1.75.

2.2 The minimum track width of the rear-wheels should generally be greater than 1 150 mm. It is recognised that there may be designs of tractors, for example, lawn mowers, narrow vineyard tractors, low profile tractors used in buildings with limited overhead clearance or in orchards, stilt tractors (high clearance) and special forestry machines, such as forwarders and skidders, for which this Standard Code is not applicable.

3. RULES AND DIRECTIONS

3.1 *General regulations*

3.1.1 The protective structure may be manufactured either by the tractor manufacturer or by an independent firm. In either case a test is only valid for the model of tractor on which it is carried out. The protective structure must be retested for each model of tractor to which it is to be fitted. However, testing stations may certify that the strength tests are also valid for tractor models derived from the original model by modifications to the engine, transmission and steering and front suspension (*see below 3.9: Extension to other tractor models*). On the other hand, more than one protective structure may be tested for any one model of tractor.

3.1.2 The protective structure submitted for static test must be supplied attached in the normal manner to the tractor or tractor chassis on which it is used. The tractor chassis shall be complete including attaching brackets and other parts of the tractor that may be affected by loads imposed on the protective structure.

3.1.3 Where a "tandem" tractor is concerned, the mass of the standard version of that part to which the protective structure is fitted is to be used.

3.1.4 A protective structure may be designed solely to protect the driver in the event of the tractor overturning. Onto this structure it may be possible to fit weather protection for the driver, of a more or less temporary nature. The driver will usually remove this in warm weather. There are protective structures however, in which the cladding is permanent and warm weather ventilation provided by windows or flaps. As the cladding may add to the strength of the structure and if removable may well be absent when an accident occurs, all parts that can be so taken away by the driver will be removed for the purpose of the test. Doors, roof hatch and windows that can be opened shall be either removed or fixed in the open position for the test, so that they do not add to the strength of the protective structure. It shall be noted whether, in this position, they would create a hazard for the driver in the event of overturning.

Throughout the remainder of these rules, reference will only be made to testing the protective structure. It must be understood that this includes cladding not of a temporary nature.

A description of any temporary cladding supplied is to be included in the specifications. All glass or similar brittle material shall be removed prior to the test. Tractor and protective structure components which might sustain needless damage during the test and which do not affect the strength of the protective structure or its dimensions may be removed prior to the test if the manufacturer wishes. No repairs or adjustment may be carried out during the test.

3.1.5 Any component of the tractor contributing to the strength of the protective structure such as mudguards, which has been reinforced by the manufacturer, should be described and its measurements given in the test report.

3.2 Apparatus

For verifying that the clearance zone has not been entered during the test, means shall be used as described in point 1.6, figures 4.9 to 4.11 and Table 4.2.

3.2.1 Horizontal loading tests (figures 4.1 to 4.5)

The following shall be used in horizontal loading tests:

3.2.1.1 material, equipment and means of attachment to ensure that the tractor chassis is firmly fixed to the ground and supported independently of the tyres;

3.2.1.2 device for applying a horizontal force to the protective structure; provision shall be made so that the load can be uniformly distributed normal to the direction of loading :

3.2.1.2.1 a beam of length not less than 250 mm nor more than 700 mm in exact multiples of 50 mm between these lengths shall be used. The beam shall have a vertical dimension of 150 mm;

3.2.1.2.2 the edges of the beam in contact with the protective structure shall be curved with a maximum radius of 50 mm;

3.2.1.2.3 universal joints or the equivalent shall be incorporated to ensure that the loading device does not constrain the protective structure in rotation or translation in any direction other than the direction of loading;

3.2.1.2.4 where the straight line defined by the appropriate beam on the protective structure is not normal to the direction of application of load the space shall be packed so as to distribute the load over the full length;

3.2.1.3 equipment for measuring force and deflection in the load direction, relative to the tractor chassis. To ensure accuracy, measurements shall be taken as continuous readings. The measuring devices shall be located so as to record the force and deflection at the point of, and along the line of, loading.

3.2.2 Crushing tests (figures 4.6 to 4.8)

The following shall be used in crushing tests:

3.2.2.1 material, equipment and means of attachment to ensure that the tractor chassis is firmly fixed to the ground and supported independently of the tyres ;

3.2.2.2 device for applying a downward force to the protective structure, including a stiff beam with a width of 250 mm ;

3.2.2.3 equipment for measuring the total vertical force applied.

3.3 Test conditions

3.3.1 The protective structure shall be to production specifications and shall be fitted to the appropriate tractor model chassis in accordance with the manufacturer's declared method of attachment.

3.3.2 The assembly shall be secured to the bedplate so that the members connecting the assembly and the bedplate do not deflect significantly in relation to the protective structure under load. The assembly shall not receive any support under load other than that due to the initial attachment.

3.3.3 An adjustable track width setting for the wheels or tracks, if present, shall be chosen such that no interference exists with the protective structure during the tests.

3.3.4 The protective structure shall be instrumented with the necessary equipment to obtain the required force-deflection data.

3.3.5 All tests shall be performed on the same protective structure. No repairs or straightening of any members shall be carried out between any parts of the test.

3.3.6 On completion of all tests, permanent deflections of the protective structure shall be measured and recorded.

3.4 Sequence of tests

Tests shall be conducted in the following sequence:

3.4.1 Longitudinal loading

For a wheeled tractor with at least 50 % of its mass on the rear axle and for tracklaying tractors, the longitudinal loading shall be applied from the rear. For other tractors the longitudinal loading shall be applied from the front.

3.4.2 First crushing test

The first crushing test shall be applied at the same end of the protective structure as the longitudinal loading.

3.4.3 Loading from the side

In the case of an offset seat or non-symmetrical strength of the protective structure, the side loading shall be on the side most likely to lead to infringement of the clearance zone.

3.4.4 Second crushing test

The second crushing test shall be applied at the end of the protective structure opposite from that receiving the first longitudinal loading. In the case of two-post designs, the second crush may be at the same point as the first crush.

3.4.5 Second longitudinal loading

3.4.5.1 A second longitudinal loading shall be applied to tractors fitted with a folding (e.g. two posts) or tiltable (e.g. non-two posts) protective structure, if one or more of the following conditions exists:

Temporary folding for special operating conditions;

Structures designed to tilt for service, unless the tilt mechanism is independent from the structural integrity of the roll-over protective structure.

3.4.5.2 For folding protective structures, if the first longitudinal loading was applied in the folding direction then a second longitudinal loading is not required.

3.5 *Horizontal loading tests from the rear, front and side*

3.5.1 General provisions

3.5.1.1 The load applied to the protective structure shall be distributed uniformly by means of a stiff beam, normal to the direction of load application (see 3.2.1.2). The stiff beam may be equipped with a means of preventing its sideways displacement. The rate of load application shall be such that it can be considered static. As the load is applied, force and deflection shall be recorded as a continuous record to ensure accuracy. Once the initial application has commenced, the load shall not be reduced until the test has been completed. The direction of the applied force shall be within the following limits:

- at start of test (no load): $\pm 2^\circ$;
- during test (under load): 10° above and 20° below the horizontal.

The rate of load application shall be considered static if the rate of deflection under loading is not greater than 5 mm/s.

3.5.1.2 If no structural cross member exists at the point of load application, a substitute test beam which does not add strength will be utilised.

3.5.2 Longitudinal loading (figures 4.1 and 4.2)

The load shall be applied horizontally and parallel to the median plane of the tractor. If the load is applied from the rear (Section 3.4.1), the longitudinal load and the lateral load shall be applied on different sides of the median plane of the tractor. If the longitudinal load is applied from the front, it shall be on the same side as the side load.

The load shall be applied to the uppermost transverse structural member of the protective structure (i.e. that part which would be likely to strike the ground first in an overturn).

The point of application of the load shall be located at one sixth of the width of the top of the protective structure inwards from the outside corner. The width of the protective structure shall be taken as the distance between two lines parallel to the median plane of the tractor touching the outside extremities of the protective structure in the horizontal plane touching the top of the uppermost transverse structural members.

In the event that the ROPS is formed of curved members and no appropriate corners exist, the following general procedure shall apply for determining W. The test engineer shall identify the curved member most likely to first strike ground in the event of an asymmetrical rear or front overturn (e.g. an overturn to the front or rear where one side of the ROPS is likely to bear the initial loading). The endpoints of W shall be the mid-points of the external radii created between other straight or curved members which form the uppermost ROPS structure. In the event that multiple curved members could be selected, the test

engineer shall establish ground lines for each possible member to determine which surface is most likely to strike ground first. See Figures 4.3 a) and b) for examples.

NOTE In the event of curved members, only the width at the end of the structure to which the longitudinal load is to be applied need be considered

The length of the load distribution device (see 3.2.1.2) shall be not less than one third of the width of the protective structure and not more than 49 mm greater than this minimum.

The longitudinal loading shall be stopped when:

3.5.2.1 the energy absorbed by the protective structure is equal to or greater than the required energy input, E_{ILI} where:

$$E_{ILI} = 1.4 M$$

3.5.2.2 the protective structure infringes on the clearance zone or leaves the clearance zone unprotected (Condition of acceptance in 3.8 below).

3.5.3 Side loading (figures 4.4 and 4.5)

The side loading shall be applied horizontally at 90° to the median plane of the tractor. It shall be applied to the upper extremity of the protective structure at a point (160 - a_h) mm forward of the seat index point.

For tractors with a reversible driver's position (reversible seat and steering wheel), it shall be applied to the upper extremity of the protective structure at the mid-point between the two seat index points.

If it is certain that any particular part of the protective structure will touch ground first when the tractor overturns sideways, the loading shall be applied at that point, provided that this permits uniform distribution of the load as specified in 3.5.1.1. In the case of a two-post protective structure, side loading shall be applied at the structural member uppermost on the side, regardless of the seat index position.

Specifications for the load distribution beam are given in Section 3.2.1.2.1.

The side loading shall be stopped when:

3.5.3.1 The energy absorbed by the protective structure is equal to or greater than the required energy, E_{IS} , where:

$$E_{IS} = 1.75 M$$

3.5.3.2 The protective structure infringes on the clearance zone or leaves the clearance zone unprotected (Condition of acceptance in 3.8 below).

3.6 Crushing tests

3.6.1 Crushing at the rear (figures 4.6, 4.7.a and 4.7.b)

3.6.1.1 The crushing beam shall be positioned across the rear uppermost structural members so that the resultant of the crushing forces is located in the vertical reference plane. The crushing force **F** shall be applied where:

$$F = 20 M$$

This force shall be maintained for 5 seconds after cessation of any visually detectable movement of the protective structure.

3.6.1.2 Where the rear part of the protective structure roof will not sustain the full crushing force, the force shall be applied until the roof is deflected to coincide with the plane joining the upper part of the protective structure with that part of the rear of the tractor capable of supporting the tractor when overturned. The force shall then be removed and the crushing beam repositioned over that part of the protective structure that would support the tractor when completely overturned. The crushing force **F = 20 M** shall then be applied.

3.6.2 Crushing at the front (figures 4.6 to 4.8)

3.6.2.1 The crushing beam shall be positioned across the front uppermost structural members so that the resultant of the crushing forces is located in the vertical reference plane. The crushing force **F** shall be applied where:

$$F = 20 M.$$

This force shall be maintained for 5 seconds after cessation of any visually detectable movement of the protective structure.

3.6.2.2 Where the front part of the roof of the protective structure will not sustain the full crushing force (figures 4.8.a and 4.8.b), the force shall be applied until the roof is deflected to coincide with the plane joining the upper part of the protective structure with that part of the front of the tractor capable of supporting the tractor when overturned. The force shall then be removed and the crushing beam repositioned over that part of the protective structure that would support the tractor when completely overturned. The crushing force **F = 20 M** shall then be applied.

3.7 *Second longitudinal loading test*

The load shall be applied in the opposite direction to and at the corner farthest from the point of application of the first longitudinal load (figures 4.1 and 4.2).

The longitudinal loading shall be stopped when:

3.7.1 The energy absorbed by the protective structure is equal to or greater than the required energy, **E_{IL2}**, where :

$$E_{IL2} = 0.35 M$$

3.7.2 The protective structure infringes on the clearance zone or leaves the clearance zone unprotected (Condition of acceptance in 3.8 below).

3.8 *Conditions for acceptance*

For the protective structure to be accepted it shall fulfil the following conditions during and after completion of the tests:

3.8.1 no part shall enter the clearance zone during any part of the tests. No part may strike the seat during the tests. Furthermore, the clearance zone shall not be outside the protection of the protective structure. For this purpose, it shall be considered to be outside the protection of the structure if any part of it would come in contact with flat ground if the tractor overturned towards the direction from which the test load is applied. For estimating this, the tyres and track width setting shall be the smallest standard fitting specified by the manufacturer;

3.8.2 for the articulated tractors, the median planes of the two parts shall be assumed to be in line;

3.8.3 after the final crushing test, the permanent deflection of the protective structure shall be recorded. For this purpose, before the start of the test, the position of the main protective structure members in relation to the seat index point must be recorded. Then any displacement of the members resulting from the loading tests and any change of the height of the front and back members of the roof of the protective structure shall be recorded;

3.8.4 at the point where the required energy absorption is met in each of the specified horizontal loading tests the force shall exceed $0.8 F_{max}$;

3.8.5 an overload test shall be required if the applied force decreases by more than 3 % over the last 5 % of the deflection attained when the energy required is absorbed by the structure (Figures 4.12 to 4.14). Description of the overload test:

3.8.5.1 an overload test shall consist of continuing the horizontal loading in increments of 5 % of the original required energy, up to a maximum of 20 % additional energy;

3.8.5.2 the overload test shall be successfully completed if after the absorption of 5, 10 or 15 % additional energy the force drops by less than 3 % for each 5 % energy increment whilst remaining greater than $0.8 F_{max}$ or if, after the absorption of 20 % additional energy the force is greater than $0.8 F_{max}$;

3.8.5.3 additional cracks or tears or entry into or lack of protection of the clearance zone, due to elastic deformation, are permitted during the overload test. After removing the load, however, the protective structure shall not infringe on the clearance zone, which shall be completely protected;

3.8.6 the required force must be sustained in both crushing tests;

3.8.7 there shall be no protruding member or component which would be likely to cause serious injury during an overturning accident or which, through the deformation occurring, might trap the operator, for example by the leg or foot;

3.8.8 there shall be no other components presenting a serious hazard to the operator.

3.9 *Extension to other tractor models*

3.9.1 Administrative extension

If there are changes in the make, denomination or marketing features of the tractor or protective structure tested or listed in the original test report, the testing station that has carried out the original test can issue an “administrative extension report”. This extension report shall contain a reference to the original test report.

3.9.2 Technical extension

When technical modifications occur on the tractor, the protective structure or the method of attachment of the protective structure to the tractor, the testing station that has carried out the original test can issue a “technical extension report” in the following cases:

3.9.2.1 Extension of the structural test results to other models of tractors

The loading and crushing tests need not be carried out on each model of tractor, provided that the protective structure and tractor comply with the conditions referred to hereunder 3.9.2.1.1 to 3.9.2.1.5.

3.9.2.1.1 The structure shall be identical to the one tested;

3.9.2.1.2 The required energy shall not exceed the energy calculated for the original test by more than 5 %. The 5 % limit shall also apply to extensions in the case of substituting tracks for wheels on the same tractor;

3.9.2.1.3 The method of attachment and the tractor components to which the attachment is made shall be identical;

3.9.2.1.4 Any components such as mudguards and bonnet that may provide support for the protective structure shall be identical;

3.9.2.1.5 The position and critical dimensions of the seat in the protective structure and the relative position of the protective structure on the tractor shall be such that the clearance zone would have remained within the protection of the deflected structure throughout all tests (this shall be checked by using the same reference of clearance zone as in the original test report, respectively Seat Reference Point [SRP] or Seat Index Point [SIP]).

3.9.2.2 Extension of the structural test results to modified models of the protective structure

This procedure has to be followed when the provisions of paragraph 3.9.2.1 are not fulfilled, it may not be used when the method of attachment of the protective structure to the tractor does not remain of the same principle (e.g. rubber supports replaced by a suspension device):

3.9.2.2.1 Modifications having no impact on the results of the initial test (e.g. weld attachment of the mounting plate of an accessory in a non-critical location on the structure), addition of seats with different SIP location in the protective structure (subject to checking that the new clearance zone(s) remain(s) within the protection of the deflected structure throughout all tests).

3.9.2.2.2 Modifications having a possible impact on the results of the original test without calling into question the acceptability of the protective structure (e.g. modification of a structural component, modification of the method of attachment of the protective structure to the tractor). A validation test can be carried out and the test results will be drafted in the extension report.

The following limits for this type extension are fixed:

3.9.2.2.2.1 No more than 5 extensions may be accepted without a validation test;

3.9.2.2.2.2 The results of the validation test will be accepted for extension if all the acceptance conditions of the Code are fulfilled and if the force measured when the required energy level has been reached in the various horizontal load tests does not deviate from the force measured when the required energy has been reached in the original test by more than $\pm 7\%$ and the deflection measured³ when the required energy level has been reached in the various horizontal load tests does not deviate from the deflection measured when the required energy has been reached in the original test report by more than $\pm 7\%$.

3.9.2.2.2.3 More than one protective structure modifications may be included in a single extension report if they represent different options of the same protective structure, but only one validation test can be accepted in a single extension report. The options not tested shall be described in a specific section of the extension report.

3.9.2.2.3 Increase of the reference mass declared by the manufacturer for a protective structure already tested. If the manufacturer wants to keep the same approval number it is possible to issue an extension report after having carried out a validation test (the limits of $\pm 7\%$ specified in 3.9.2.2.2.2 are not applicable in such a case).

3.10 Labelling

3.10.1 OECD labelling is optional. If it is utilised, it shall contain at least the following information:

3.10.1.1 name and address of the manufacturer of the protective structure;

3.10.1.2 protective structure identification number (design or serial number);

3.10.1.3 tractor make, model(s) or series number(s) that the protective structure is designed to fit;

3.10.1.4 OECD approval number of test report

³ Permanent + elastic deflection measured at the point when the required energy level is obtained.

3.10.2 The label shall be durable and permanently attached to the protective structure such that it can be easily read and it shall be protected from environmental damage.

3.11 Cold weather performance of protective structures

3.11.1 If the protective structure is claimed to have properties resistant to cold weather embrittlement, the manufacturer shall give details that shall be included in the report.

3.11.2 The following requirements and procedures are intended to provide strength and resistance to brittle fracture at reduced temperatures. It is suggested that the following minimum material requirements shall be met in judging the protective structure's suitability at reduced operating temperatures in those countries requiring this additional operating protection.

3.11.2.1 Bolts and nuts used to attach the protective structure to the tractor and used to connect structural parts of the protective structure shall exhibit suitable controlled reduced temperature toughness properties.

3.11.2.2 All welding electrodes used in the fabrication of structural members and mounts shall be compatible with the protective structure material as given in 3.11.2.3 below.

3.11.2.3 Steel materials for structural members of the protective structure shall be of controlled toughness material exhibiting minimum Charpy V-Notch loading energy requirements as shown in Table 4.1. Steel grade and quality shall be specified in accordance with ISO 630:1995; Amd1:2003.

Steel with an as-rolled thickness less than 2.5 mm and with a carbon content less than 0.2 % is considered to meet this requirement. Structural members of the protective structure made from materials other than steel shall have equivalent low temperature loading resistance.

3.11.2.4 When testing the Charpy V-Notch loading energy requirements, the specimen size shall be no less than the largest of the sizes stated in Table 4.1 that the material will permit.

3.11.2.5 The Charpy V-Notch tests shall be made in accordance with the procedure in ASTM A 370-1979, except for specimen sizes that shall be in accordance with the dimensions given in Table 4.1.

3.11.2.6 Alternatives to this procedure are the use of killed or semi-killed steel for which an adequate specification shall be provided. Steel grade and quality shall be specified in accordance with ISO 630:1995; Amd1:2003.

3.11.2.7 Specimens are to be longitudinal and taken from flat stock, tubular or structural sections before forming or welding for use in the protective structure. Specimens from tubular or structural sections are to be taken from the middle of the side of greatest dimension and shall not include welds.

Specimen size	Energy at	Energy at
	-30 °C	-20 °C
mm	J	J ^{b)}
10 x 10 ^{a)}	11	27.5
10 x 9	10	25
10 x 8	9.5	24
10 x 7,5 ^{a)}	9.5	24
10 x 7	9	22.5
10 x 6.7	8.5	21
10 x 6	8	20
10 x 5 ^{a)}	7.5	19
10 x 4	7	17.5
10 x 3.5	6	15

Table 4.1
Minimum Charpy V-notch impact energies

- ^{a)} Indicates preferred size. Specimen size shall be no less than largest preferred size that the material permits.
- ^{b)} The energy requirement at -20 °C is 2.5 times the value specified for -30 °C. Other factors affect impact energy strength, i.e. direction of rolling, yield strength, grain orientation and welding. These factors shall be considered when selecting and using steel.

3.12 Seatbelt anchorage performance (optional)

3.12.1 Scope

Seat belts are one of the operator restraint systems used for securing the driver in motor vehicles.

This recommended procedure provides minimum performance and tests requirements for anchorage for agricultural and forestry tractors.

It applies to the anchorage of pelvic restraint systems.

3.12.2 Explanation of terms used in the performance testing

3.12.2.1 The *seat belt assembly* is any strap or belt device fastened across the lap or pelvic girdle area designed to secure a person in a machine.

3.12.2.2 The *extension belt* is intended as any strap, belt, or similar device that aids in the transfer of seat belt loads.

3.12.2.3 The *anchorage* is intended as the point where the seat belt assembly is mechanically attached to the seat system or tractor.

3.12.2.4 The *seat mounting* is intended as all intermediary fittings (such as slides, etc.) used to secure the seat to the appropriate part of the tractor.

3.12.2.5 The *Operator Restraint System* is intended as the total system composed of seat belt assembly, seat system, anchorages and extension which transfers the seat belt load to the tractor.

3.12.2.6 *Applicable Seat Components* comprise all components of the seat whose mass could contribute to loading of the seat mounting (to the vehicle structure) during a roll-over event.

3.12.3 Test procedure

Only static tests for anchorages are given in this procedure.

If, for a given protective structure, a manufacturer provides more than one totally identical seat with regard to the seatbelt anchorage performance test, the Testing Station is authorized to test only one configuration, corresponding to the heaviest seat (*see also below*).

The seat shall be in position during the tests and fixed to the mounting point on the tractor using all intermediary fittings (such as suspension, slides, etc.) specified for the complete tractor. No additional non-standard fittings contributing to the strength of the construction may be used.

The worst case loading scenario for seat belt anchorage performance testing should be identified with consideration to the following points:-

- If the masses of alternative seats are comparable, those featuring seat belt anchorages which transfer loading through the seat structure (*e.g. via the suspension system and/or adjustment slides*), will be required to withstand much higher test loading. They are therefore likely to represent the worst case;
- If the applied loading will pass through the seat mountings to the vehicle chassis, the seat should be adjusted longitudinally to achieve the minimum amount of overlap of the mounting slides / rails. This will usually be when the seat is in the fully-rearward position but, if certain vehicle installations limit seat rearward travel, the fully-forward seat position may provide the worst case loading position. Observation of the amount of seat movement and mounting slide / rail overlap is required.

The anchorages shall be capable of withstanding the loads applied to the seat belt system using a device as shown in Figure 4.15. The seat belt anchorages shall be capable of withstanding these test loads applied with the seat adjusted in the worst position of the longitudinal adjustment to ensure that the test condition is met. The test loads shall be applied with the seat in the mid-position of the longitudinal adjustment if a worst position among the possible seat adjustments is not recognised by the testing station. For a suspended seat, the seat shall be set to the midpoint of the suspension travel, unless this is contradictory to a clearly stated instruction by the seat manufacturer. Where special instructions exist for the seat setting, these shall be observed and specified in the report.

After the load is applied to the seat system, the load application device shall not be repositioned to compensate for any changes that may occur to the load application angle.

3.12.3.1 Forward loading

A tensile force shall be applied in a forward and upward direction at an angle of $45^\circ \pm 2^\circ$ to the horizontal, as shown in Figure 4.16. The anchorages shall be capable of withstanding a force of 4 450 N. In the event that the force applied to the seat belt assembly is transferred to the vehicle chassis by means of the seat, the seat mounting shall be capable of withstanding this force plus an

additional force equal to four times the force of gravity on the mass of all applicable seat components, applied $45^\circ \pm 2^\circ$ to the horizontal in a forward and upward direction, as shown in Figure 4.16.

3.12.3.2 Rearward loading

A tensile force shall be applied in a rearward and upward direction at an angle of $45^\circ \pm 2^\circ$ to the horizontal, as shown in Figure 4.17. The anchorages shall be capable of withstanding a force of 2 225 N. In the event that the force applied to the seat belt assembly is transferred to the vehicle chassis by means of the seat, the seat mounting shall be capable of withstanding this force plus an additional force equal to two times the force of gravity on the mass of all applicable seat components, applied $45^\circ \pm 2^\circ$ to the horizontal in a rearward and upward direction, as shown in Figure 4.17.

Both tensile forces shall be equally divided between the anchorages.

3.12.3.3 Seatbelt buckle release force (if required by the manufacturer)

The seat belt buckle shall open with a maximum force of 140 N following the load applications. This requirement is fulfilled for seat belt assemblies that satisfy the requirements of UN-ECE R-16 or Directive 77/541/EEC as last amended.

3.12.4. Test result

Condition of acceptance

Permanent deformation of any system component and anchorage area is acceptable under the action of the forces specified in 3.12.3.1 and 3.12.3.2. However, there shall be no failure allowing release of the seat belt system, seat assembly, or the seat adjustment locking mechanism.

The seat adjuster or locking device need not be operable after application of the test load.

The results of a test performed on an identical “operator restraint system” may be included in more than one test report provided that this system is fitted exactly in the same conditions.

The results of a test performed after the approval of the test report of the protective structure shall be drafted in a technical extension report.

Dimensions in mm

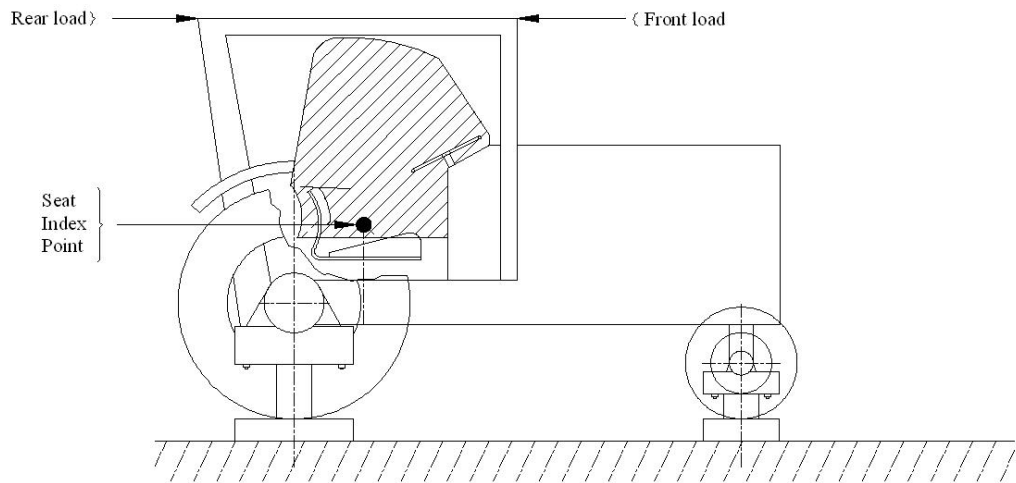

Figure 4.1.a Protective cab

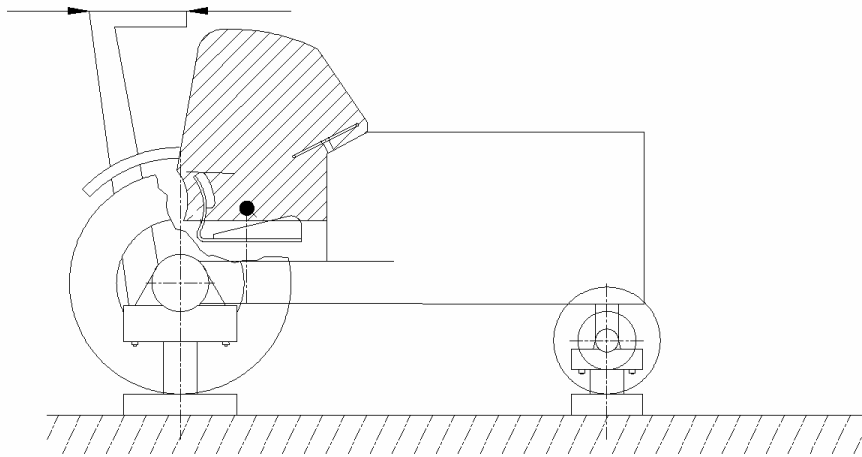

Figure 4.1.b Rear roll bar frame

Figure 4.1

**Front and rear load applications,
protective cab and rear roll bar frame**

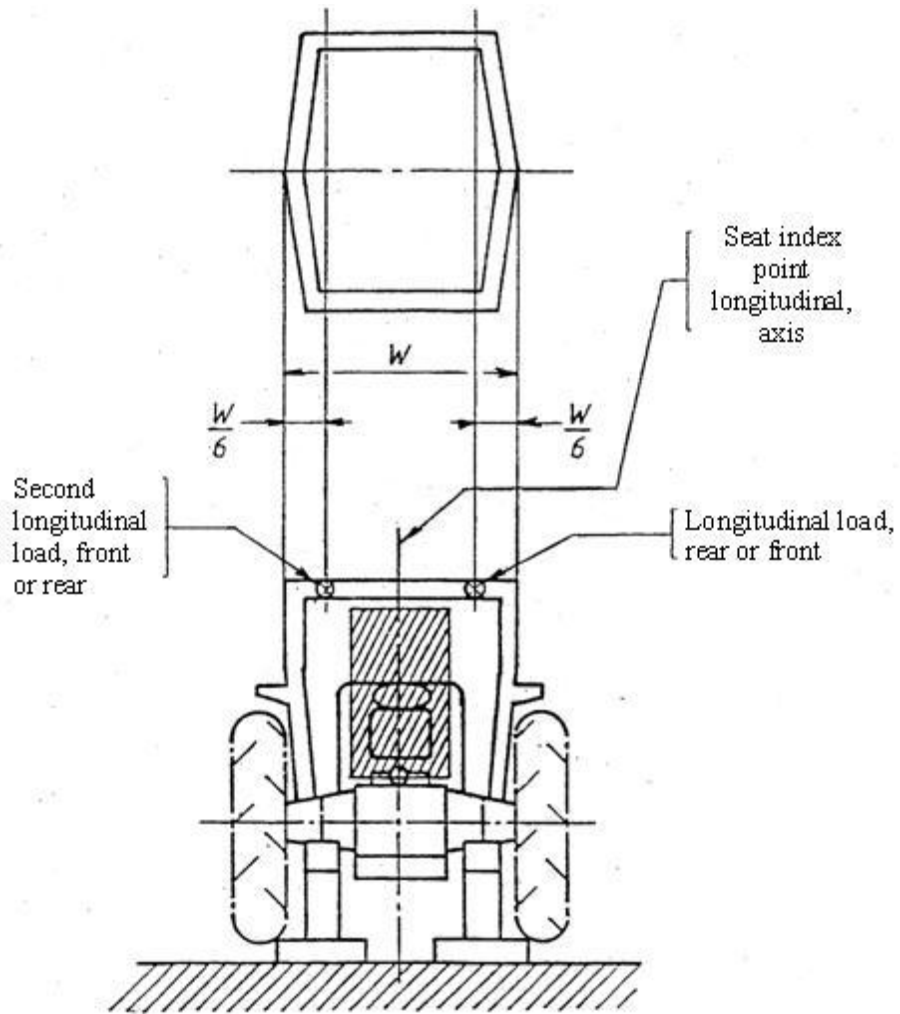
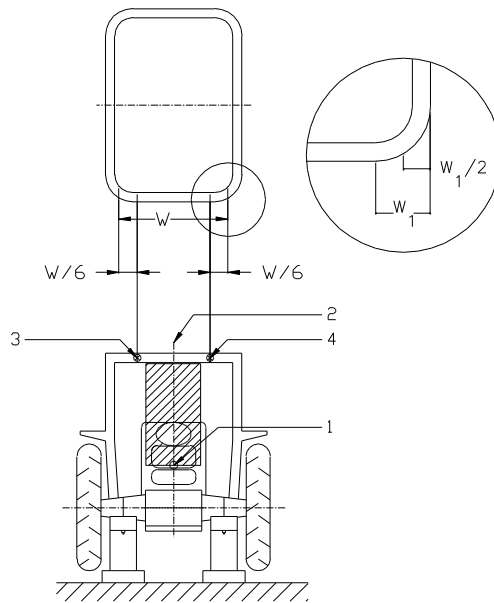

Figure 4.2

Longitudinal load applications



KEY

- 1 – Seat index point
- 2 – SIP, longitudinal centre-plane
- 3 – Point of second longitudinal load application, front or rear
- 4 – Point of longitudinal load application, rear or front

Figure 4.3.a Four-post ROPS

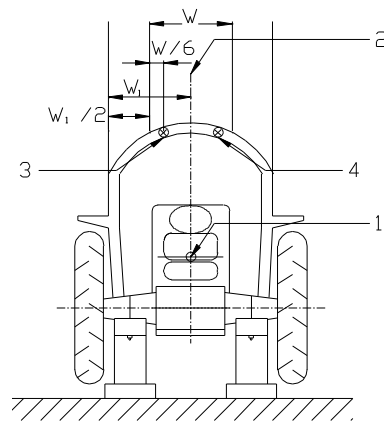

Figure 4.3.b Two-post ROPS

KEY

- 1 – Seat index point (SIP)
- 2 – SIP, longitudinal centre-plane
- 3 – Point of second longitudinal load application, front or rear
- 4 – Point of longitudinal load application, rear or front

Figure 4.3

Examples of ‘W’ for ROPS with curved members

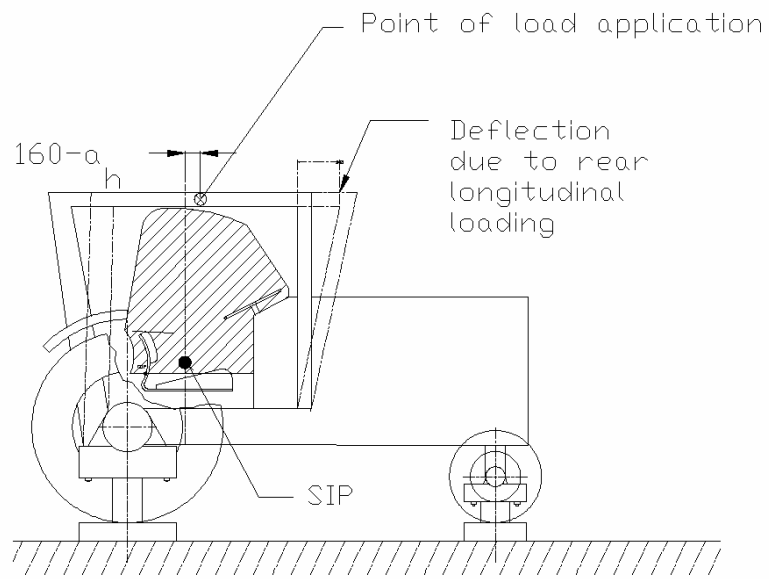

Figure 4.4.a Protective cab

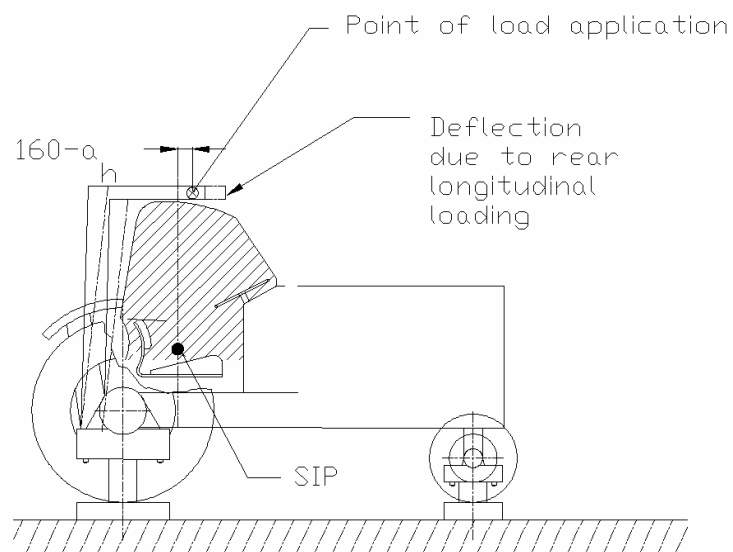

Figure 4.4.b Rear roll bar frame

Figure 4.4

**Side load application (side view),
protective cab and rear roll bar frame**

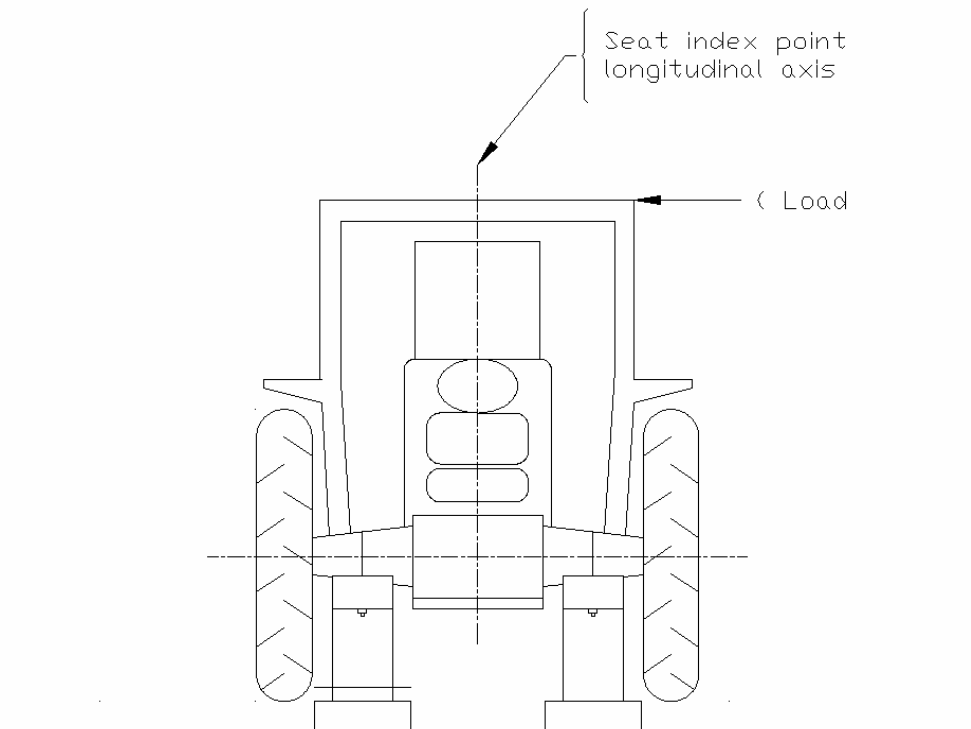

Figure 4.5

Side load application (rear view)

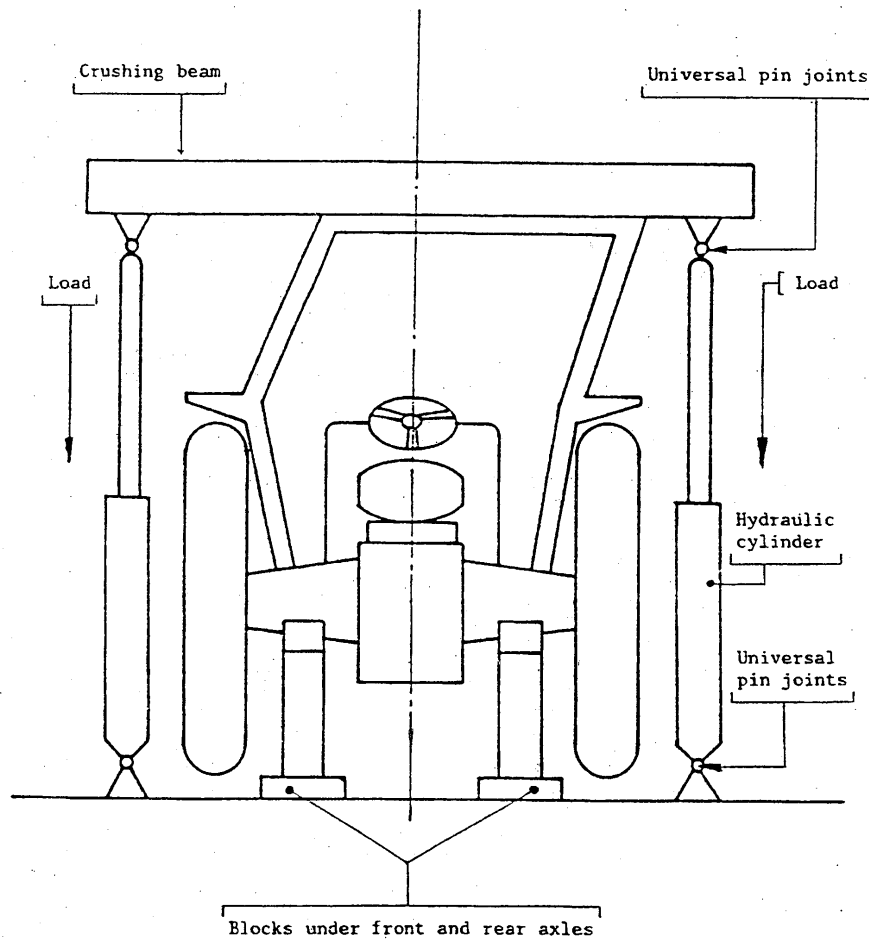

Figure 4.6

Example of arrangement for crushing test

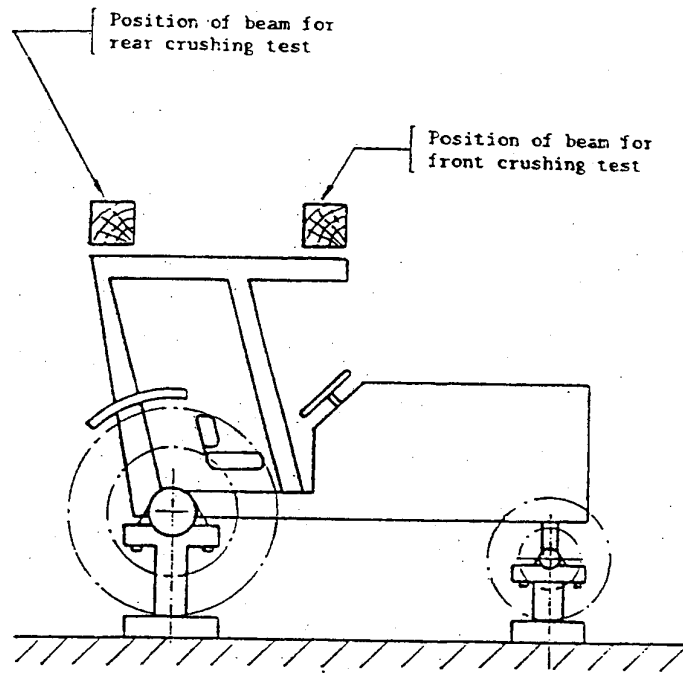

Figure 4.7.a Protective cab

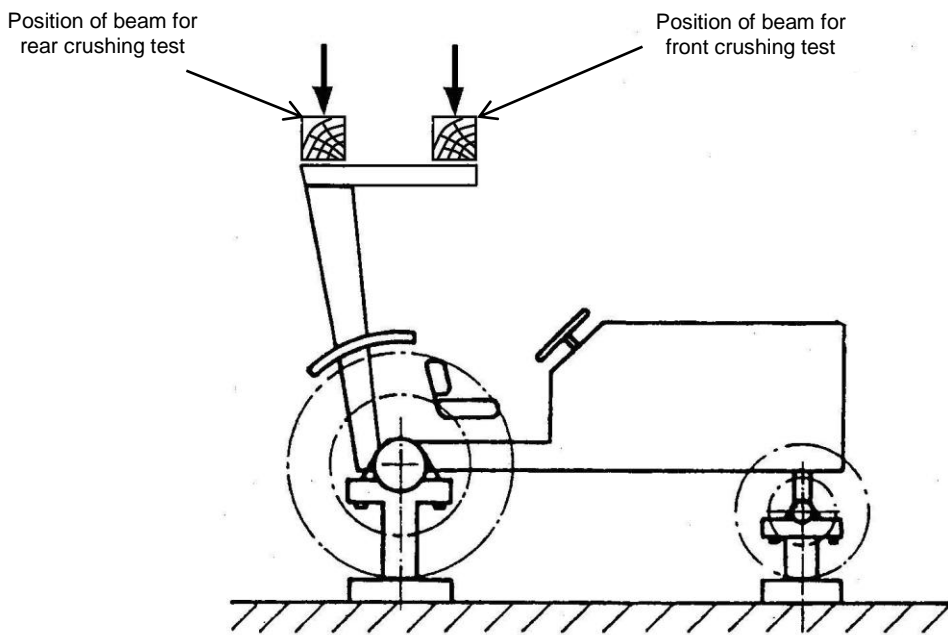

Figure 4.7.b Rear roll bar frame

Figure 4.7

**Position of beam for front and rear crushing tests,
protective cab and rear roll bar frame**

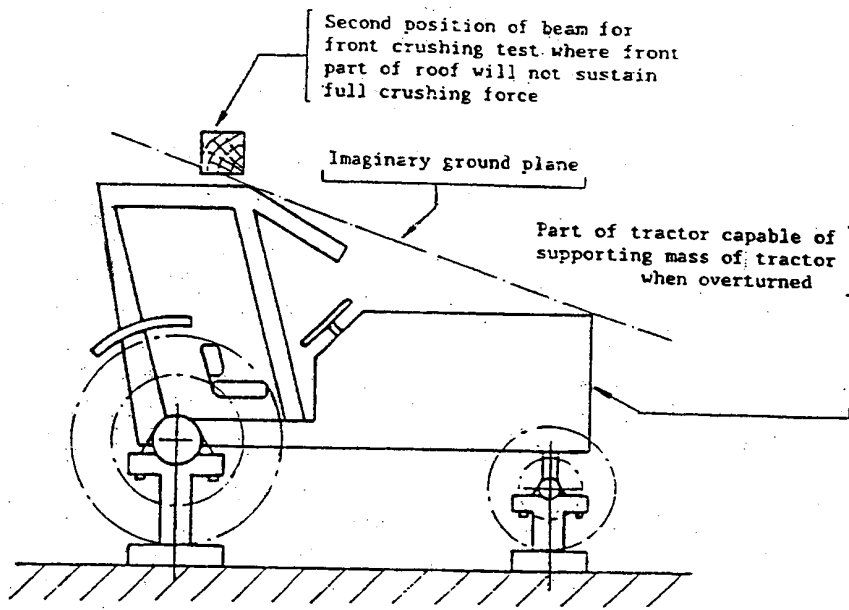

Figure 4.8.a Protective cab

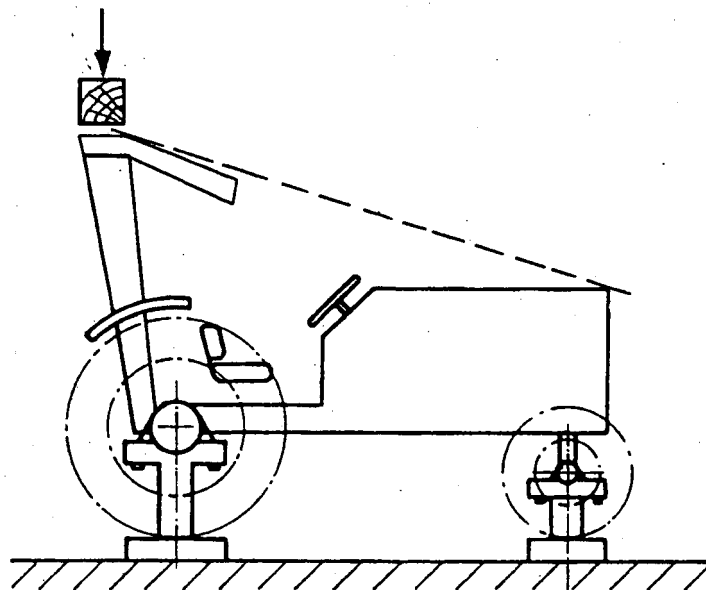

Figure 4.8.b Rear roll bar frame

Figure 4.8

Position of beam for front crushing test when full crushing force not sustained in front

Dimensions	mm	Remarks
A ₁ A ₀	100	minimum
B ₁ B ₀	100	minimum
F ₁ F ₀	250	minimum
F ₂ F ₀	250	minimum
G ₁ G ₀	250	minimum
G ₂ G ₀	250	minimum
H ₁ H ₀	250	minimum
H ₂ H ₀	250	minimum
J ₁ J ₀	250	minimum
J ₂ J ₀	250	minimum
E ₁ E ₀	250	minimum
E ₂ E ₀	250	minimum
D ₀ E ₀	300	minimum
J ₀ E ₀	300	minimum
A ₁ A ₂	500	minimum
B ₁ B ₂	500	minimum
C ₁ C ₂	500	minimum
D ₁ D ₂	500	minimum
I ₁ I ₂	500	minimum
F ₀ G ₀	-	depending on the tractor
I ₀ G ₀	-	
C ₀ D ₀	-	
E ₀ F ₀	-	

Table 4.2

Dimensions of the clearance zone

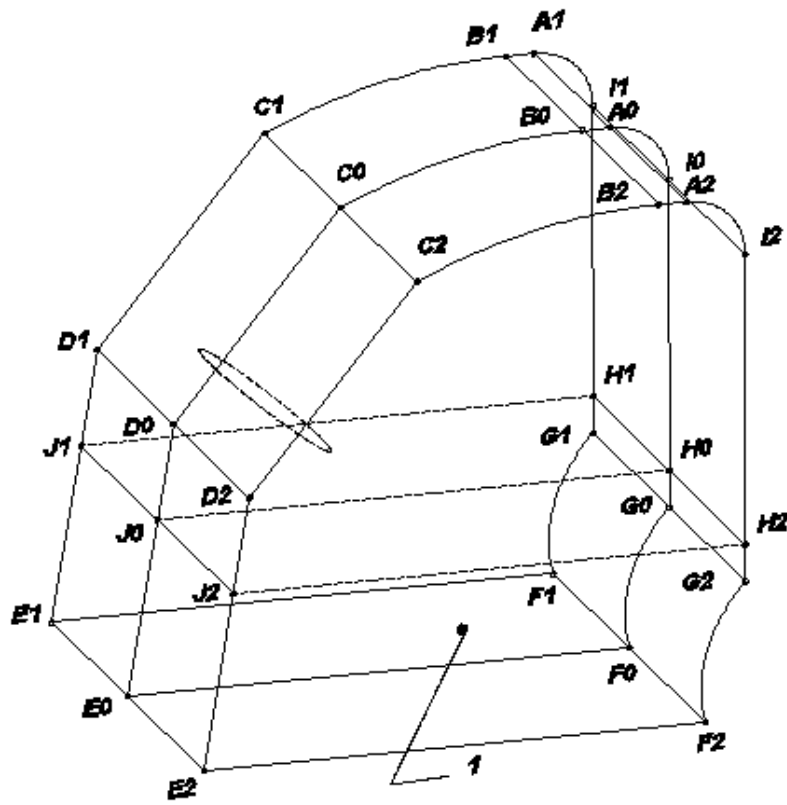

1 – Seat index point

Figure 4.9

Clearance zone

Note: for dimensions, see Table 4.2 above

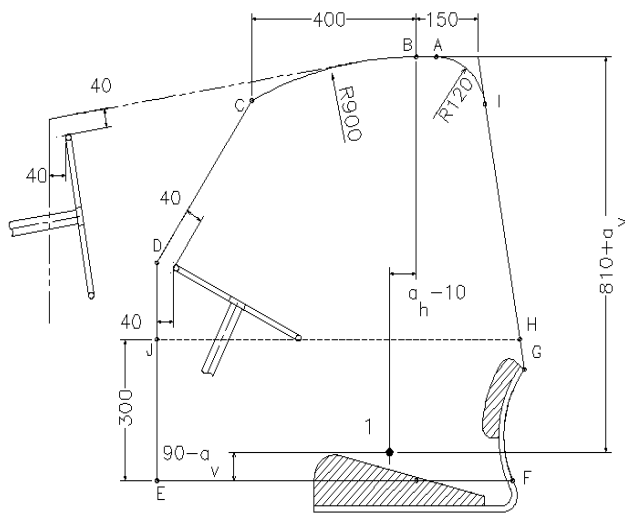

Figure 4.10.a
side view
section in reference plan

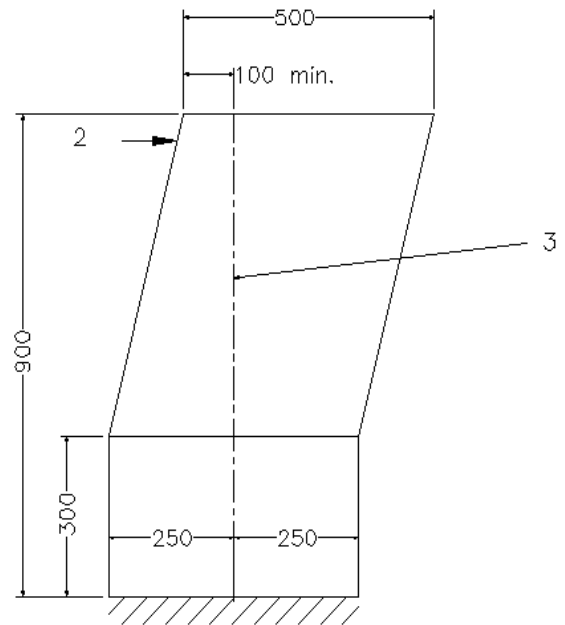

Figure 4.10.b
rear or front view

- 1 – Seat index point
- 2 – Force
- 3 – Vertical reference plane

Figure 4.10
Clearance zone

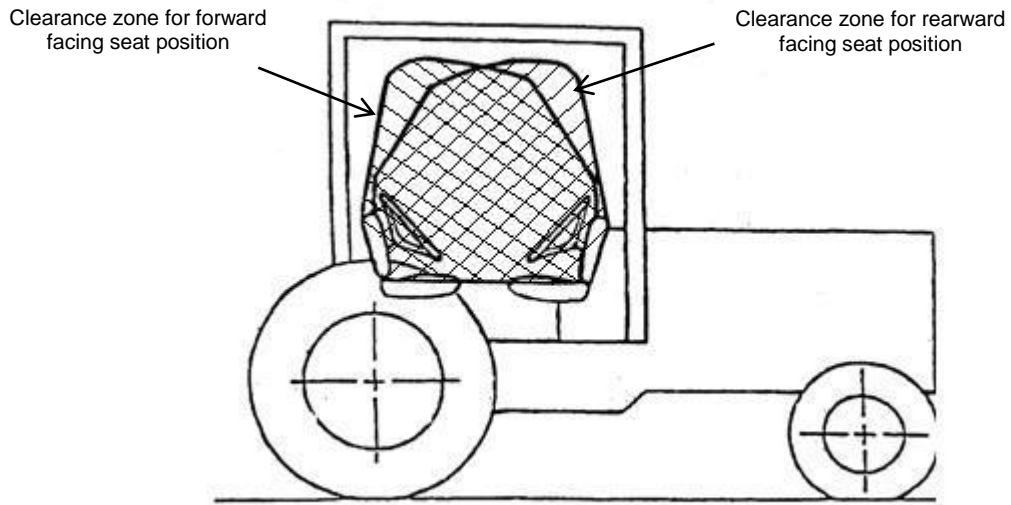

Figure 4.11.a Protective cab

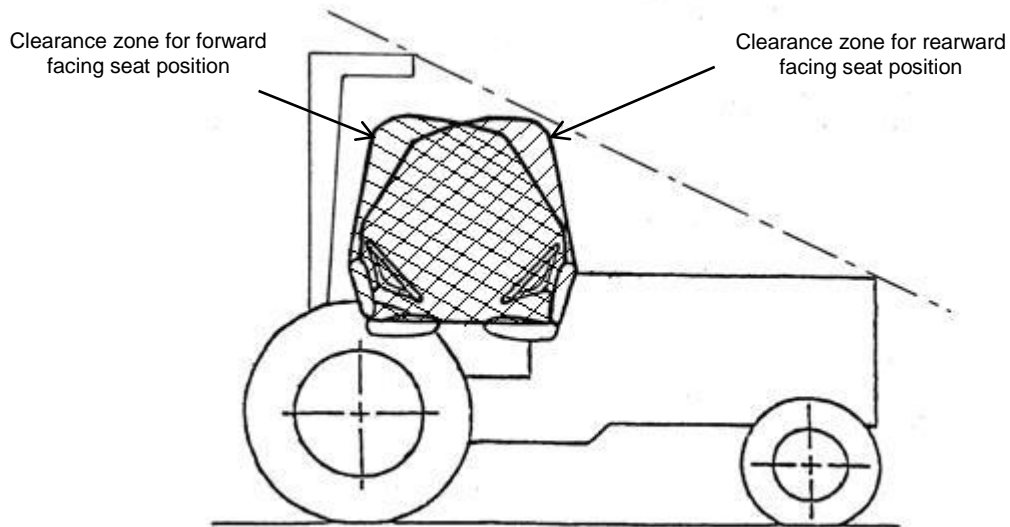
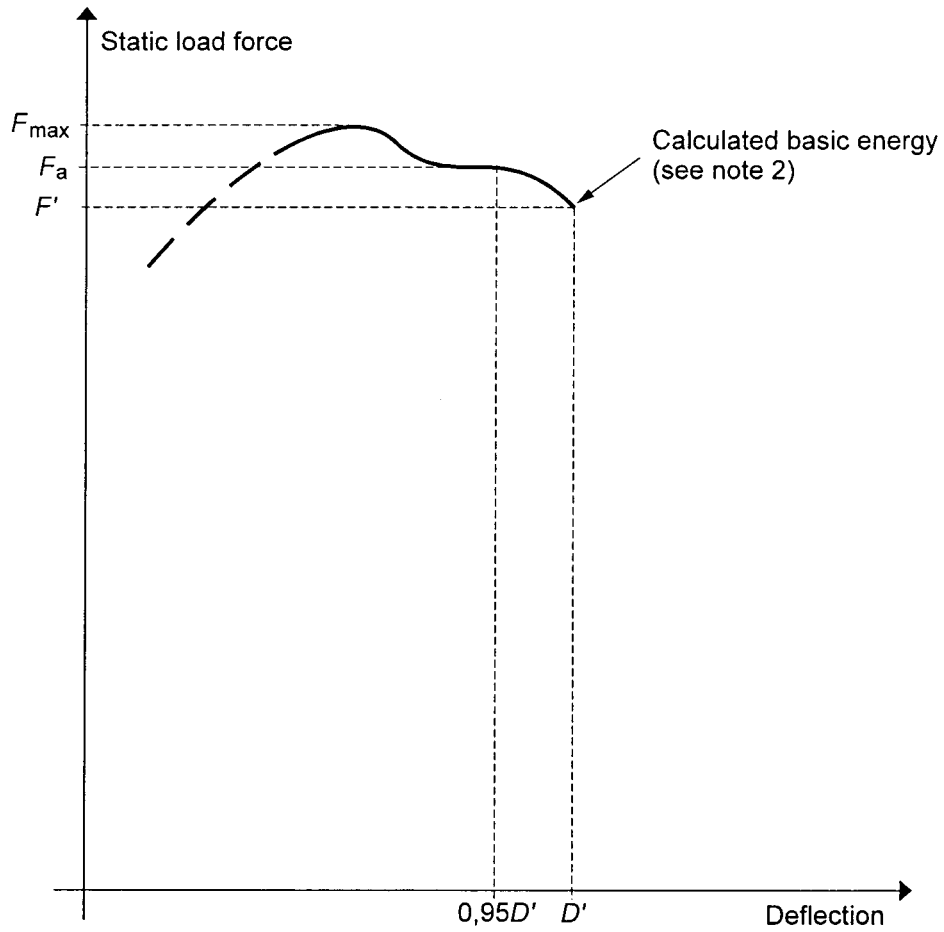

Figure 4.11.b Rear roll bar frame

Figure 4.11

**Clearance zone for tractor with reversible seat and steering wheel,
protective cab and rear roll bar frame**



Notes:

1. Locate F_a in relation to $0,95 D'$
2. Overload test not necessary as $F_a \leq 1,03 F'$

Figure 4.12

**Force / deflection curve
Overload test not necessary**

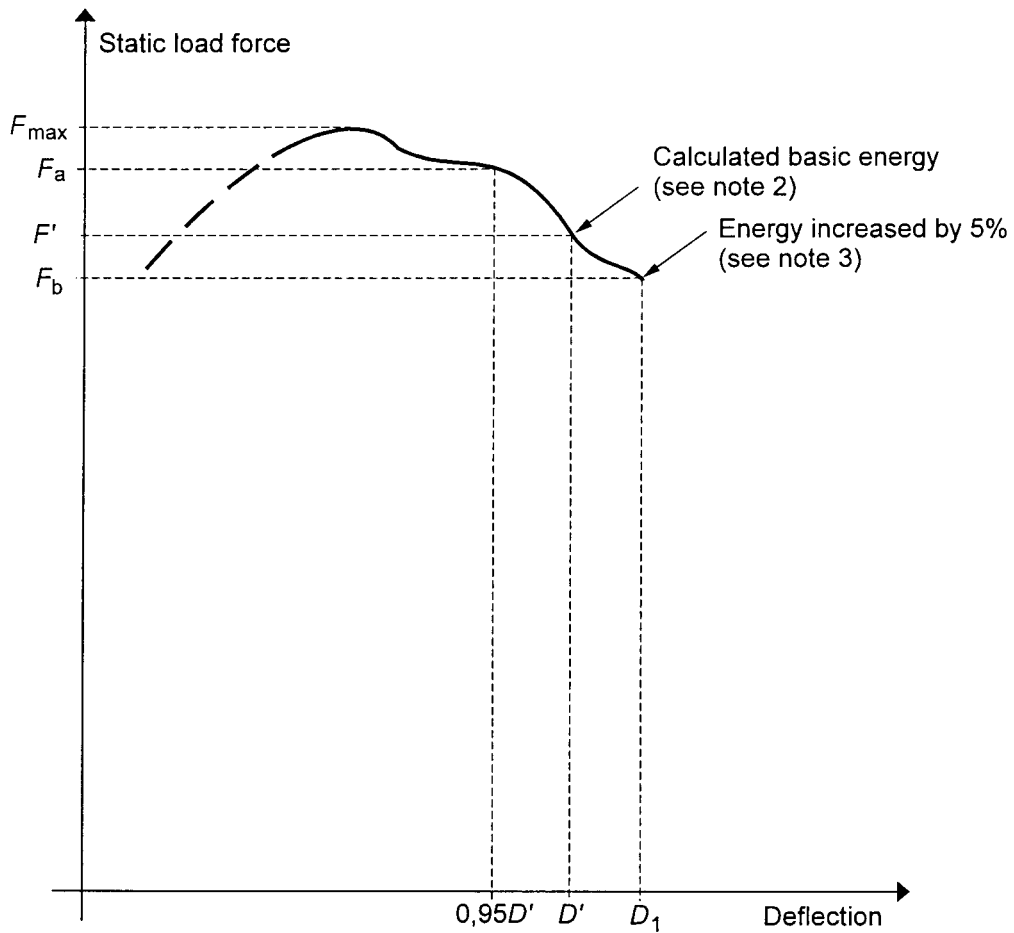

Notes:

1. Locate F_a in relation to $0,95 D'$
2. Overload test necessary as $F_a > 1,03 F'$
3. Overload test performance satisfactory as $F_b > 0,97F'$ and $F_b > 0,8F_{max}$

Figure 4.13

**Force / deflection curve
Overload test necessary**

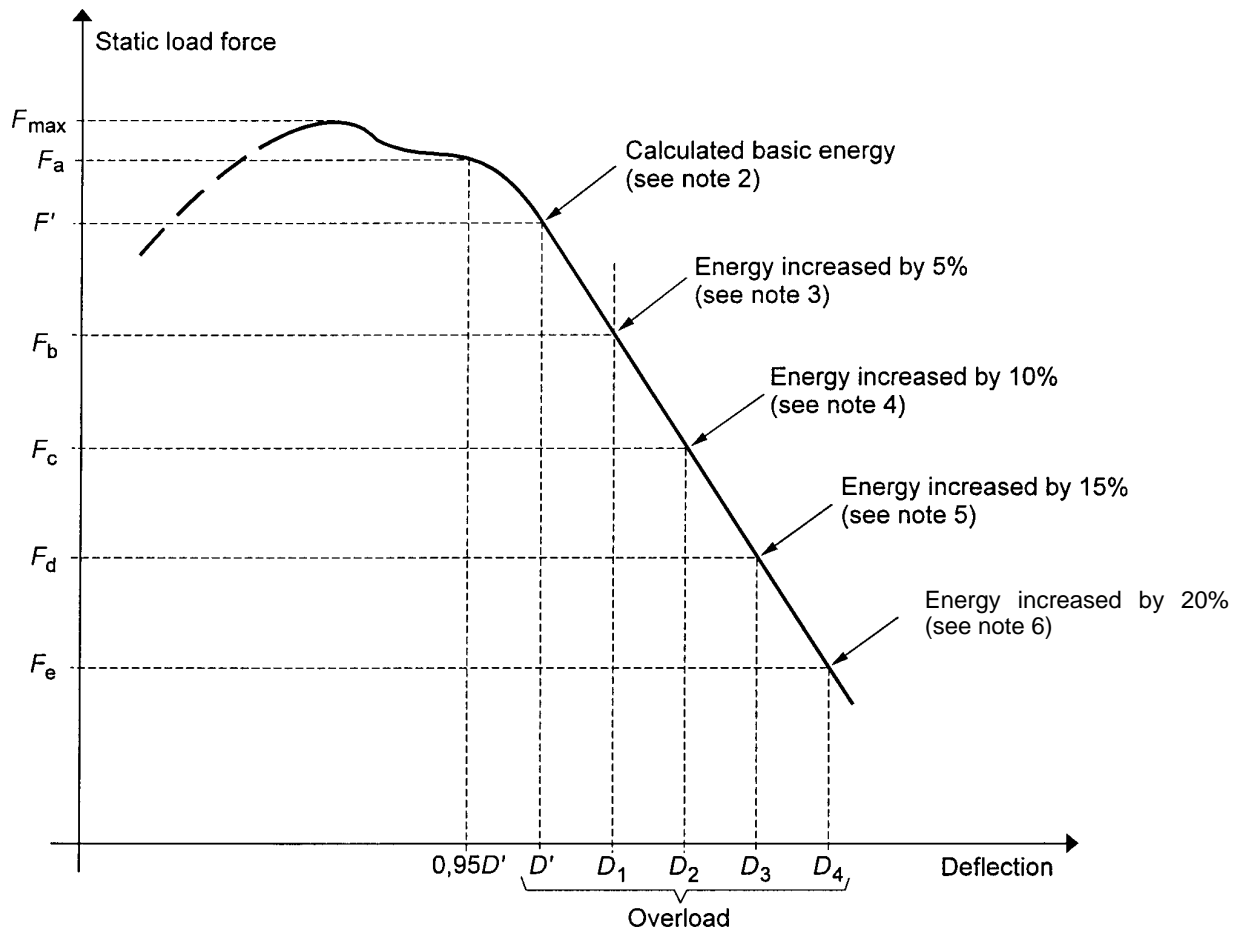

Notes:

1. Locate F_a in relation to $0,95 D'$
2. Overload test necessary as $F_a > 1,03 F'$
3. $F_b < 0,97 F'$ therefore further overload necessary
4. $F_c < 0,97 F_b$ therefore further overload necessary
5. $F_d < 0,97 F_c$ therefore further overload necessary
6. Overload test performance satisfactory, if $F_e > 0,8 F_{max}$
7. Failure at any stage when load drops below $0,8 F_{max}$

Figure 4.14

**Force / deflection curve
Overload test to be continued**

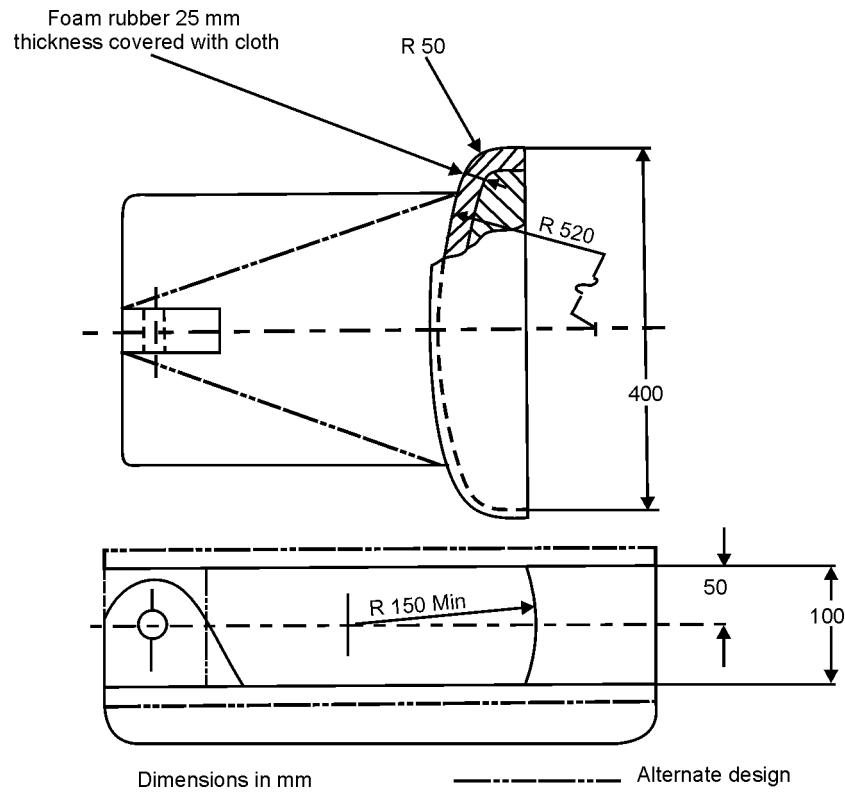

Figure 4.15

The load application device

Note: The dimensions not shown are optional to satisfy the test facility and do not influence the test results.

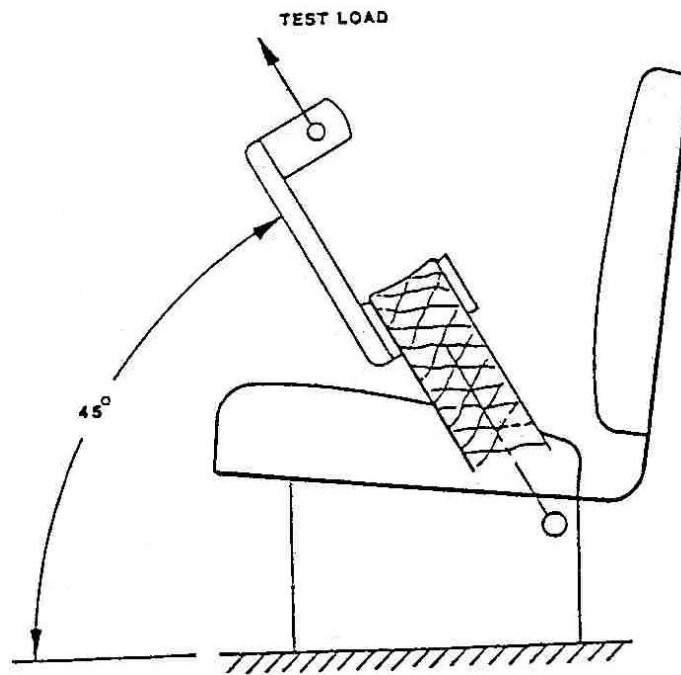

Figure 4.16

Load application in the upward and forward direction

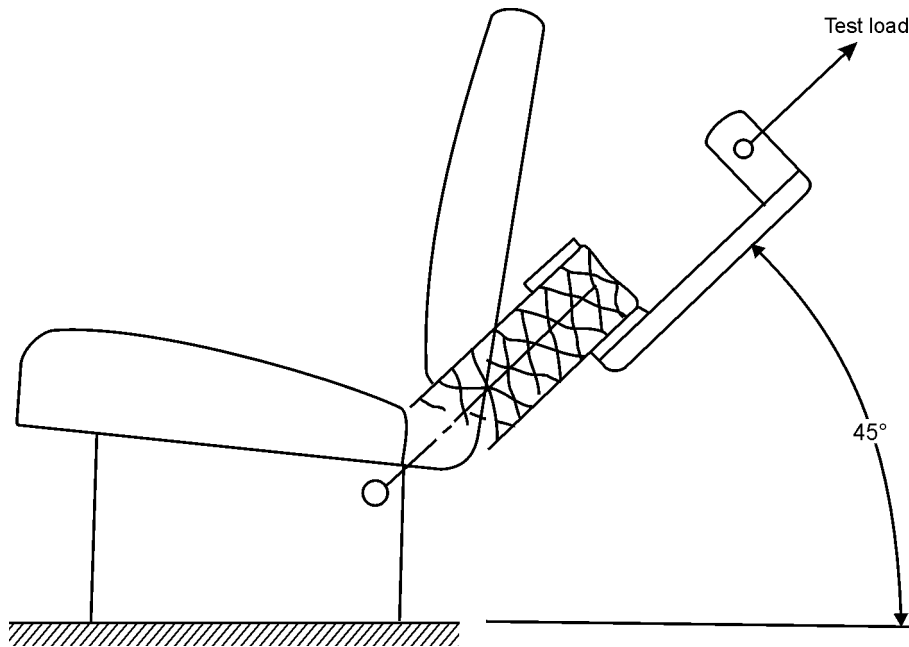

Figure 4.17

Load application in the upward and rearward direction

SPECIMEN TEST REPORT

Note: Units shown below, which appear in ISO 1000:1992; Amd1:1998, shall be stated and followed by national units in parentheses, if necessary.

- Protective structure manufacturer’s name and address:
- Submitted for test by:

- Make of the protective structure:
- Model of the protective structure:
- Type of the protective structure: *Cab, Frame, Rear rollbar, Cab with integrated frame, etc.*

- Date, location of test and Code version:

1. SPECIFICATION OF TEST TRACTOR

1.1 Identification of tractor to which the protective structure is fitted for the test

- 1.1.1 - Make of the tractor: (*)
 - Model (trade name):
 - Type: 2 *WD* or 4 *WD*; *rubber or steel tracks (if applicable); articulated 4 WD or articulated 4 WD with twin (dual) wheels (if applicable)*

(*) possibly different from tractor manufacturer's name

- 1.1.2 Numbers
 - 1st Serial No. or prototype No.:
 - Serial No.:

1.2 Mass of unballasted tractor with protective structure fitted and without driver

Front	kg
Rear	kg
Total	kg

- Maximum permissible mass of tractor: kg
- Reference mass used for calculating loading energies and crushing forces: kg
- Mass Ratio value - (*Maximum Permissible Mass / Reference Mass*):-

1.3 Minimum track and tyre sizes

	Minimum track	Tyre sizes
Front	mm	
Rear	mm	

1.4 Tractor seat

- Tractor with a reversible driver’s position (reversible seat and steering wheel): Yes / No
- Make/ type/ model of seat:
- Make/ type/ model of optional seat(s)
and position(s) of the seat index point (SIP) :
 - (description of seat 1 and SIP position)
 - (description of seat 2 and SIP position)
 - (description of seat _ and SIP position)
- Seat belt anchorage: Type
- Seat mounting on the tractor: Type
- Other seat components: Type
- Total mass of the seat: (kg)

2. SPECIFICATION OF PROTECTIVE STRUCTURE

2.1 Photographs from side and rear showing mounting details including mudguards

2.2 General arrangement drawing of the side and the rear of the structure including position of the seat index points (SIP), details of mountings and position of the front part of the tractor capable of supporting the tractor when overturned (if necessary). The main dimensions must figure on the drawings, including external dimensions of tractor with protective structure fitted and main interior dimensions.

2.3 Brief description of the protective structure comprising:

- type of construction;
- details of mountings;
- details of the front part of the tractor capable of supporting the tractor when overturned (if necessary)
- means of access and escape;
- additional frame: Yes / No

2.4 Tiltable or not tiltable/ Folding or not folding structure

-- Tiltable / not tiltable (*)

If it is necessary to tilt with any tools, this should be stated as follows:

-- Tiltable with tools/ tiltable without tools (*)

-- Folding/ not folding (*)

If it is necessary to fold with any tools, this should be stated as follows:

-- Folding with tools/ folding without tools (*)

(*) *delete as appropriate*

2.5 Dimensions

Dimensions should be measured with seatpan and backrest loaded and adjusted according to Definition 1.5 of the Code.

When the tractor is fitted with different optional seats or has a reversible driver's position (reversible seat and steering wheel), the dimensions in relation to the seat index points shall be measured in each case (SIP 1, SIP 2, etc.).

2.5.1	Height of roof members above the seat index point:	mm
2.5.2	Height of roof members above the tractor footplate:	mm
2.5.3	Interior width of the protective structure (810 + a _v) mm above the seat index point:	mm
2.5.4	Interior width of the protective structure vertically above the seat index point at the level of centre of the steering wheel:	mm
2.5.5	Distance from the centre of the steering wheel to the right-hand side of the protective structure:	mm
2.5.6	Distance from the centre of the steering wheel to the left-hand side of the protective structure:	mm
2.5.7	Minimum distance from the steering wheel rim to the protective structure:	mm
2.5.8	Horizontal distance from the seat index point to the rear of the protective structure at a height of (810 + a _v) mm above the seat index point:	mm
2.5.9	Position (with reference to the rear axle) of the front part of the tractor capable of supporting the tractor when overturned (if necessary):	
	horizontal distance	mm
	vertical distance	mm

2.6 Details of materials used in the construction of the protective structure and specifications of steels used

Steel specifications shall be in conformity with ISO 630:1995; Amd1:2003.

2.6.1 Main frame: (parts - material - sizes)

- steel standard and reference:

- 2.6.2 Mountings: (parts - material - sizes)
- steel standard and reference:
- 2.6.3 Assembly and mounting bolts: (parts - sizes)
- 2.6.4 Roof (if equipped): (parts - material - sizes)
- 2.6.5 Cladding (if equipped): (parts - material - sizes)
- 2.6.6 Glass (if equipped): (type - grade - sizes)
- 2.6.7 Front part of the tractor capable of supporting the tractor when overturned (if necessary) (parts - material - sizes)

2.7. Details of tractor manufacturer's reinforcements on original parts

3. TEST RESULTS

3.1 Static loading and crushing tests

3.1.1 Condition of tests

- Loading tests were made:

- to the rear left / right
- to the front right / left
- to the side right / left

- Mass used for calculating loading energies and crushing forces: kg

- Energies and forces applied:

- rear: kJ
- front: kJ
- side: kJ
- crushing force: kN

3.1.2 Permanent deflections measured after the tests

3.1.2.1 Permanent deflections of the extremities of the protective structure measured after the series of tests:

- Back (forwards / backwards):

- left-hand: mm
- right-hand: mm

- Front (forwards / backwards):

- left-hand: mm
- right-hand: mm

- Sideways (to the left / to the right):

- front: mm
 - rear: mm
- Top (downwards / upwards):
- rear: left-hand: mm
 - right-hand: mm
 - front: left-hand: mm
 - right-hand: mm
- 3.1.2.2 Difference between total instantaneous deflection and residual deflection during sideways loading test (elastic deflection): mm

Statement:

The acceptance conditions of these tests relative to the protection of the clearance zone are fulfilled. The structure is a roll-over protective structure in accordance with the Code.

3.1.3 Curves

A copy of the force/deflection curves derived during the tests shall be included.

If a horizontal overload test was required, the reason for the overload shall be described and the copy of additional force/deflection curves obtained during overload shall be included.

3.2 Cold weather performance (resistance to brittle fracture)

Method used to identify resistance to brittle fracture at reduced temperature:

- .
- .
- .

Steel specifications shall be in conformity with ISO 630:1995; Amd1:2003.

Steel specification: (reference and relevant standard)

3.3 Anchorage performance

3.3.1 Loading in the forward and upward direction

Driver seat	Make/Model/Type	
GRAVITY FORCE ($F_g = \text{seat mass} \times 9.81$) N	REQUIRED FORCE ($4450 + 4 F_g$) N	APPLIED FORCE N

3.3.2. Loading in the rearward and upward direction

Driver seat	Make/Model/Type	
GRAVITY FORCE	REQUIRED FORCE	APPLIED FORCE

(Fg = seat mass x 9.81) N	(2225 + 2 Fg) N	N

3.3.3 Curves, drawings and photos

A copy of the force/deflection curves derived during the tests shall be included.

Drawings and/or photos of the seat mounting and anchorages have to be added.

Statement (if necessary):

The testing station certifies that the tested seat is the worst variant among the seats listed below that are identical regarding the make, range and fixing on the protective structure.

Statement:

During the test, no structural failure or release of seat, seat adjuster mechanism or other locking service occurred. The seat and safety belt anchorage tested fulfil the requirement of the OECD procedure.

3.4 Tractor(s) to which the protective structure is fitted

OECD Approval Number:										
Make	Model	Type	Other specifications	Mass			Tiltable	Wheel-Base	Minimum track	
				Front	Rear	Total			Front	Rear
		<i>2/4 WD, etc</i>	<i>where applicable</i>	kg	kg	kg	Yes/ No	mm	mm	

SPECIMEN TECHNICAL EXTENSION REPORT

Note: Units shown below, which appear in ISO 1000:1992; Amd1:1998, shall be stated and followed by national units in parentheses, if necessary.

- Protective structure manufacturer's name and address:
- Submission for extension by:

- Make of the protective structure:
- Model of the protective structure:
- Type of the protective structure: *Cab, Frame, Rear rollbar, Cab with integrated frame, etc.*

- Date, location of extension and Code version:

- Reference of the original test:
- Approval number and date of the original test report:

- Statement giving the reasons of the extension and explaining the procedure chosen (e.g. extension with validation test):

Depending on the case some of the following paragraphs may be omitted if their content is identical to the one of the original test report. It is only necessary to highlight the differences between the tractor and protective structure described in the original test report and the one for which the extension has been required.

1. SPECIFICATION OF TEST TRACTOR

1.1 Identification of tractor to which the protective structure is fitted for the test

- 1.1.1 - Make of the tractor: (*)
- Model (trade name):
- Type: *2 WD or 4 WD; rubber or steel tracks (if applicable); articulated 4 WD or articulated 4 WD with twin (dual) wheels (if applicable)*

(*) *possibly different from tractor manufacturer's name*

1.1.2 Numbers

- 1st Serial No. or prototype:
- Serial No.:

1.1.3 Other specifications (if applicable)

- Model denomination(s) for other countries:
- Transmission type or gears x ranges:
- Speed version: *30 or 40 km/h:*
- Manufacturer identification or Technical type number:

1.2 Mass of unballasted tractor with protective structure fitted and without driver

Front	kg
Rear	kg
Total	kg

- Maximum permissible mass of tractor: kg
- Reference mass used for calculating loading energies and crushing forces: kg
- Mass Ratio value - (*Maximum Permissible Mass / Reference Mass*):-

1.3 Minimum track and tyre sizes

	Minimum track	Tyre sizes
Front	mm	
Rear	mm	

1.4 Tractor seat

- Tractor with a reversible driver’s position (reversible seat and steering wheel): Yes / No
- Make/ type/ model of seat:
- Make/ type/ model of optional seat(s) and position(s) of the seat index point (SIP) :
 - (description of seat 1 and SIP position)
 - (description of seat 2 and SIP position)
 - (description of seat _ and SIP position)
- Seat belt anchorage: Type
- Seat mounting on the tractor: Type
- Other seat components: Type
- Seat operating position in the test: Description

Masses used for calculating the loads

Seat	Make/Model/Type
COMPONENTS	MASS (kg)
Driver seat:	
Seat belt assembly:	
Other seat components:	
Total:	

2. SPECIFICATION OF PROTECTIVE STRUCTURE

2.1 Photographs from side and rear showing mounting details including mudguards

2.2 General arrangement drawing of the side and the rear of the structure including position of the seat index points (SIP), details of mountings and position of the front part of the tractor capable of supporting the tractor when overturned (if necessary). The main dimensions must figure on the drawings, including external dimensions of tractor with protective structure fitted and main interior dimensions.

2.3 Brief description of the protective structure comprising:

- type of construction;
- details of mountings;
- details of cladding and padding;
- details of the front part of the tractor capable of supporting the tractor when overturned (if necessary);
- means of access and escape;
- additional frame: Yes / No

2.4 Tiltable or not tiltable/ Folding or not folding structure

-- Tiltable / not tiltable (*)

If it is necessary to tilt with any tools, this should be stated as follows:

-- Tiltable with tools/ tiltable without tools (*)

-- Folding/ not folding (*)

If it is necessary to fold with any tools, this should be stated as follows:

-- Folding with tools/ folding without tools (*)

(*) *delete as appropriate*

2.5 Dimensions

Dimensions should be measured with seatpan and backrest loaded and adjusted according to Definition 1.5 of the Code.

When the tractor is fitted with different optional seats or has a reversible driver's position (reversible seat and steering wheel), the dimensions in relation to the seat index points shall be measured in each case (SIP 1, SIP 2, etc.).

- 2.5.1 Height of roof members above the seat index point: mm
- 2.5.2 Height of roof members above the tractor footplate: mm
- 2.5.3 Interior width of the protective structure
(810 + a_v) mm above the seat index point: mm

2.5.4	Interior width of the protective structure vertically above the seat index point at the level of centre of the steering wheel:	mm
2.5.5	Distance from the centre of the steering wheel to the right-hand side of the protective structure:	mm
2.5.6	Distance from the centre of the steering wheel to the left-hand side of the protective structure:	mm
2.5.7	Minimum distance from the steering wheel rim to the protective structure:	mm
2.5.8	Width of the doorways <ul style="list-style-type: none"> • at the top: • in the middle: • at the bottom: 	 mm mm mm
2.5.9	Height of the doorways <ul style="list-style-type: none"> • above foot platforms: • above highest mounting steps: • above lowest mounting steps: 	 mm mm mm
2.5.10	Overall height of the tractor with the protective structure fitted:	mm
2.5.11	Overall width of the protective structure (if mudguards are included, this is to stated):	mm
2.5.12	Horizontal distance from the seat index point to the rear of the protective structure at a height of $(810 + a_v)$ mm above the seat index point:	mm
2.5.13	Position (with reference to the rear axle) of the front part of the tractor capable of supporting the tractor when overturned (if necessary) <ul style="list-style-type: none"> • horizontal distance: • vertical distance: 	 mm mm

2.6 Details of materials used in the construction of the protective structure and specifications of steels used

Steel specifications shall be in conformity with ISO 630:1995; Amd1:2003.

2.6.1	Main frame: <ul style="list-style-type: none"> • Is steel rimmed, semi-killed or killed?: • steel standard and reference: 	(parts - material - sizes)
2.6.2	Mountings: <ul style="list-style-type: none"> • Is steel rimmed, semi-killed or killed?: • steel standard and reference: 	(parts - material - sizes)
2.6.3	Assembly and mounting bolts:	(parts - sizes)
2.6.4	Roof:	(parts - material - sizes)

- 2.6.5 Cladding: (parts - material - sizes)
- 2.6.6 Glass: (type - grade - sizes)
- 2.6.7 Front part of the tractor capable of supporting the tractor when overturned (if necessary) (parts - material - sizes)

2.7. Details of tractor manufacturer's reinforcements on original parts

3. TEST RESULTS (in case of a validation test)

3.1 Static loading and crushing tests

3.1.1 *Condition of tests*

- Loading tests were made:

- to the rear left / right
- to the front right / left
- to the side right / left

- Mass used for calculating loading energies and crushing forces: kg

- Energies and forces applied:

- rear: kJ
- front: kJ
- side: kJ
- crushing force: kN

3.1.2 Permanent deflections measured after the tests

3.1.2.1 Permanent deflections of the extremities of the protective structure measured after the series of tests:

- Back (forwards / backwards):

- left-hand: mm
- right-hand: mm

- Front (forwards / backwards):

- left-hand: mm
- right-hand: mm

- Sideways (to the left / to the right):

- front: mm
- rear: mm

- Top (downwards / upwards):

- rear: left-hand: mm
- right-hand: mm
- front: left-hand: mm
- right-hand: mm

3.1.2.2 Difference between total instantaneous deflection and residual deflection during sideways loading test (elastic deflection): mm

Statement:

The difference between the original tested models and the models for which the extension has been required are:

- ...
-

The results of the validation test fulfil the $\pm 7\%$ conditions (if relevant)

The test station has checked the modifications and certifies that the effect of these modifications does not affect the results on the strength of the protective structure.

The acceptance conditions relative to the protection of the clearance zone are fulfilled. The structure is a roll-over protective structure in accordance with the Code.

3.1.3 Curves

A copy of the force/deflection curves derived during the tests shall be included (in the case of a validation test).

	Deflection measured when required energy level has been reached			Force measured when required energy level has been reached		
	original test mm	validation test mm	relative deviation %	original test kN	validation test kN	relative deviation %
First longitudinal loading test						
Lateral loading test						
Second longitudinal test						

If a horizontal overload test was required, the reason for the overload shall be described and the copy of additional force/deflection curves obtained during overload shall be included.

3.2 Cold weather performance (resistance to brittle fracture)

Method used to identify resistance to brittle fracture at reduced temperature:

- .
- .

Steel specifications shall be in conformity with ISO 630:1995; Amd1:2003.

Steel specification: (reference and relevant standard)

3.3 Anchorage performance

3.3.1 Loading in the forward and upward direction

Driver seat	Make/Model/Type	
GRAVITY FORCE ($F_g = \text{seat mass} \times 9.81$) N	REQUIRED FORCE ($4450 + 4 F_g$) N	APPLIED FORCE N

3.3.2. Loading in the rearward and upward direction

Driver seat	Make/Model/Type	
GRAVITY FORCE ($F_g = \text{seat mass} \times 9.81$) N	REQUIRED FORCE ($2225 + 2 F_g$) N	APPLIED FORCE N

3.3.3 Curves, drawings and photos

A copy of the force/deflection curves derived during the tests shall be included.

Drawings and/or photos of the seat mounting and anchorages have to be added.

Statement:

During the test, no structural failure or release of seat, seat adjuster mechanism or other locking service occurred. The seat and safety belt anchorage tested fulfil the requirement of the OECD procedure.

3.4 Tractor(s) to which the protective structure is fitted

OECD Approval Number:										
Make	Model	Type <i>2/4 WD, etc</i>	Other specifi- cations <i>where applicable</i>	Mass			Tiltable <i>Yes/No</i>	Wheel- Base mm	Minimum track	
				Front kg	Rear kg	Total kg			Front	Rear

SPECIMEN ADMINISTRATIVE EXTENSION REPORT

Note: Units shown below, which appear in ISO 1000:1992; Amd1:1998, shall be stated and followed by national units in parentheses, if necessary.

- Submitted for extension by:
- Date, location of extension and Code version:

- Reference of the original test:
- Approval number and date of the original test:

- Statement giving the reasons of the extension and explaining the procedure chosen.

1. Specification of the protective structure

- Frame or Cab:
- Manufacturer:
- Make:
- Model:
- Type:
- Serial Number from which modification applies:

2. Denomination of tractor(s) to which the protective structure is fitted

OECD Approval Number:										
Make	Model	Type	Other specifications	Mass			Tiltable	Wheel-Base	Minimum track	
				Front	Rear	Total			Front	Rear
		<i>2/4 WD, etc</i>	<i>where applicable</i>	kg	kg	kg	<i>Yes/No</i>	mm	mm	

3. Details of modifications

Since the original test report the following modifications have been made:

4. Statement

The modifications do not to affect the results of the original test.

The original test report therefore applies.

ANNEX I

**CLEARANCE ZONE REFERRED TO
THE SEAT REFERENCE POINT**

INTRODUCTION

The paragraphs considered in the Annex refer to the definitions of the seat reference point (SRP) and the clearance zone of ROPS based on the SRP as the reference point. The numbering of the paragraphs is the same of the corresponding paragraphs in the main Code.

In the case of extension reports to test reports that originally used SRP, required measurements shall be made with reference to SRP instead of SIP. Moreover, the use of SRP shall be clearly indicated. For drafting such extension reports, the paragraphs detailed in the Annex should be followed. For the paragraphs non-reported in the Annex, previous version of Code 4 should be considered.

1. DEFINITIONS

1.5 *Determination of seat reference point; Seat location and adjustment for test*

1.5.1 Seat reference point

1.5.1.1 The reference must be established by means of the apparatus illustrated in Figures 4.18, 4.19 and 4.20. The apparatus consists of a seat pan board and backrest boards. The lower backrest board is jointed in the region of the ischium humps (**A**) and loin (**B**), the joint (**B**) being adjustable in height.

1.5.1.2 The seat reference point is defined as the point in the median longitudinal plane of the seat where the tangential plane of the lower backrest and a horizontal plane intersect. This horizontal plane cuts the lower surface of the seat pan board 150 mm in front of the above-mentioned tangent.

1.5.1.3 The apparatus is positioned on the seat. It is then loaded with a force of 550 N at a point 50 mm in front of joint (**A**), and the two parts of the backrest board lightly pressed tangentially against the backrest.

1.5.1.4 If it is not possible to determine definite tangents to each area of the backrest (above and below the lumbar region), the following steps must be taken:

where no definite tangent to the lower area is possible, the lower part of the backrest board is pressed against the backrest vertically;

where no definite tangent to the upper area is possible, the point (**B**) is fixed at a height of 230 mm above the lower surface of the seat pan board, the backrest board being perpendicular to the seat pan board. Then the two parts of the backrest board are lightly pressed against the backrest tangentially.

1.5.2 Seat location and adjustment for test

1.5.2.1 Where the seat position is adjustable, the seat must be adjusted to its rear uppermost position;

1.5.2.2 where the inclination of the backrest and seat pan is adjustable, these must be adjusted so that the reference point is in its rear uppermost position;

1.5.2.3 where the seat is equipped with suspension, the latter must be blocked at mid-travel, unless this is contrary to the instructions clearly laid down by the seat manufacturer;

1.5.2.4 where the position of the seat is adjustable only lengthwise and vertically, the longitudinal axis passing through the seat reference point shall be parallel with the vertical longitudinal plane of the tractor passing through the centre of the steering wheel and not more than 100 mm from that plane.

1.6 Clearance zone

1.6.1 Vertical reference plane

The clearance zone (Figures 4.21 to 4.24 and Table 4.2) is defined in relation to the vertical reference plane. The vertical plane, generally longitudinal to the tractor and passing through the seat reference point and the centre of the steering wheel. Normally the vertical reference plane coincides with the median plane of the tractor. This vertical reference plane shall be assumed to move horizontally with the seat and steering wheel during loading but to remain perpendicular to the tractor or the floor of the protective structure.

1.6.2 Determination of clearance zone

The clearance zone is defined as follows with the tractor standing on a horizontal surface and, where applicable, the steering wheel adjusted to the mid-position for seated driving:

1.6.2.1 A horizontal plane ($A_1 B_1 B_2 A_2$) 900 mm above the seat reference point;

1.6.2.2 An inclined plane ($G_1 G_2 I_2 I_1$) perpendicular to the reference plane and including both a point 900 mm directly above the seat reference point and the rearmost point of the seat backrest;

1.6.2.3 A cylindrical surface ($A_1 A_2 I_2 I_1$) perpendicular to the reference plane, with a radius of 120 mm, tangential to the planes defined in 1.6.2.1 and 1.6.2.2 above;

1.6.2.4 A cylindrical surface ($B_1 C_1 C_2 B_2$) perpendicular to the reference plane, having a radius of 900 mm extending forward for 400 mm and tangential to the plane defined in 1.6.2.1 above at a point 150 mm forward of the seat reference point;

1.6.2.5 An inclined plane ($C_1 D_1 D_2 C_2$) perpendicular to the reference plane, joining the surface defined in 1.6.2.4 above at its forward edge and passing 40 mm from the forward external edge of the steering wheel. In case of a high steering wheel position, this plane extends forward from $B_1 B_2$ tangentially to the surface under 1.6.2.4;

1.6.2.6 A vertical plane ($D_1 E_1 E_2 D_2$) perpendicular to the reference plane 40 mm forward of the external edge of the steering wheel (see 1.6.2.5 for the case of a high steering wheel position);

1.6.2.7 A horizontal plane ($E_1 F_1 F_2 E_2$) through the seat reference point;

1.6.2.8 A surface ($G_1 F_1 G_2 F_2$), if necessary curved, from the bottom limit of the plane defined in 1.6.2.2 above, to the horizontal plane defined in 1.5.2.7, perpendicular to the reference plane, and in contact with the seat backrest throughout its length;

1.6.2.9 Vertical planes ($J_1 E_1 F_1 G_1 H_1$) and ($J_2 E_2 F_2 G_2 H_2$). These vertical planes shall extend upwards from the seat reference point for 300 mm; the distances $E_1 E_0$ and $E_2 E_0$ shall be 250 mm;

1.6.2.10 Parallel planes ($A_1 B_1 C_1 D_1 J_1 H_1 I_1$) and ($A_2 B_2 C_2 D_2 J_2 H_2 I_2$) inclined so that the upper edge of the plane on the side on which the force is applied, is at least 100 mm from the vertical reference plane.

1.6.3 Tractors with a reversible driver's position

For tractors with a reversible driver's position (reversible seat and steering wheel), the clearance zone is the envelope of the two clearance zones defined by the two different positions of the steering wheel and the seat (Figures 4.24.a and 4.24.b).

1.6.4 Optional seats

1.6.4.1 In case of tractors that could be fitted with optional seats, the envelope comprising the seat reference points of all the options offered shall be used during the tests. The protective structure shall not enter the larger clearance zone which takes account of these different seat reference points.

1.6.4.2 In the case where a new seat option is offered after the test has been performed, a determination shall be made to see whether the clearance zone around the new SRP falls within the envelope previously established. If it does not, a new test must be performed.

Dimensions in mm

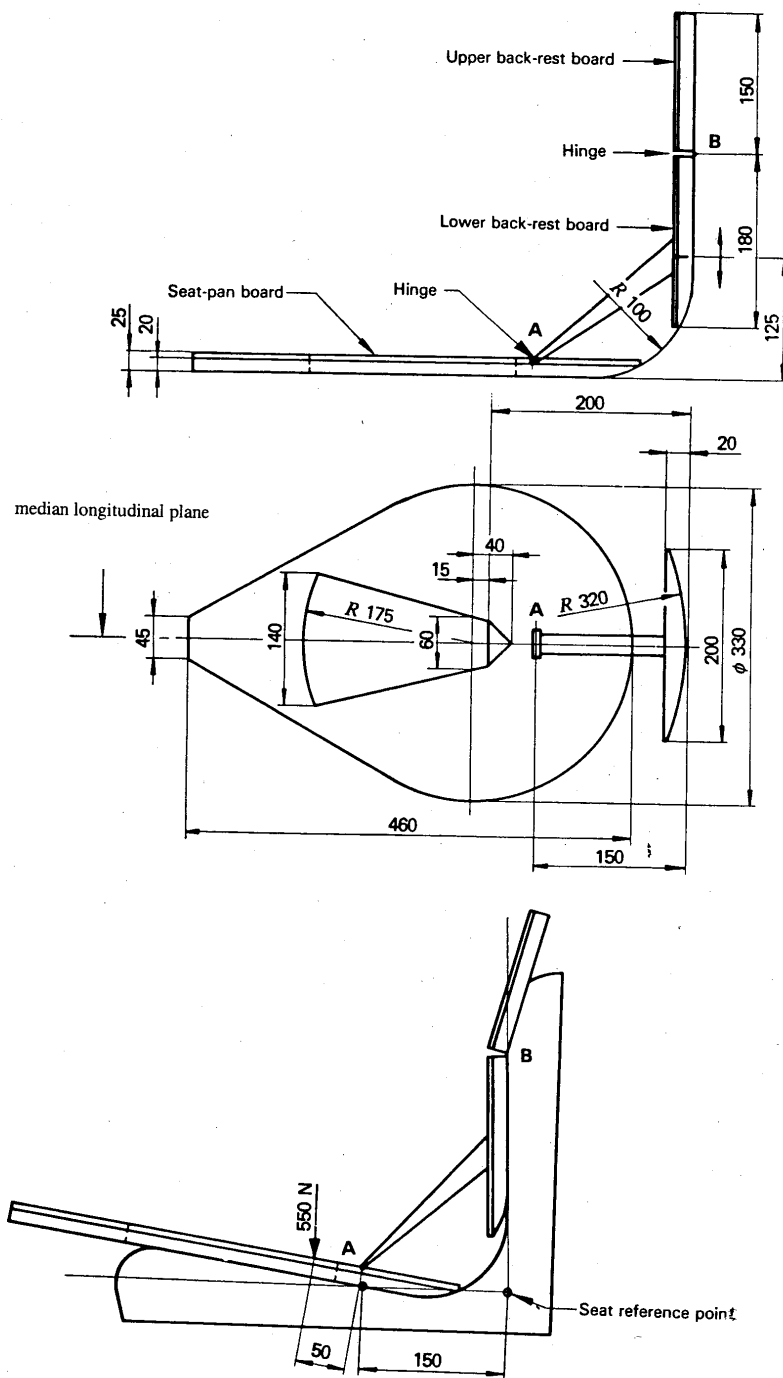

Figures 4.18, 4.19 and 4.20

Apparatus for determination of seat reference point

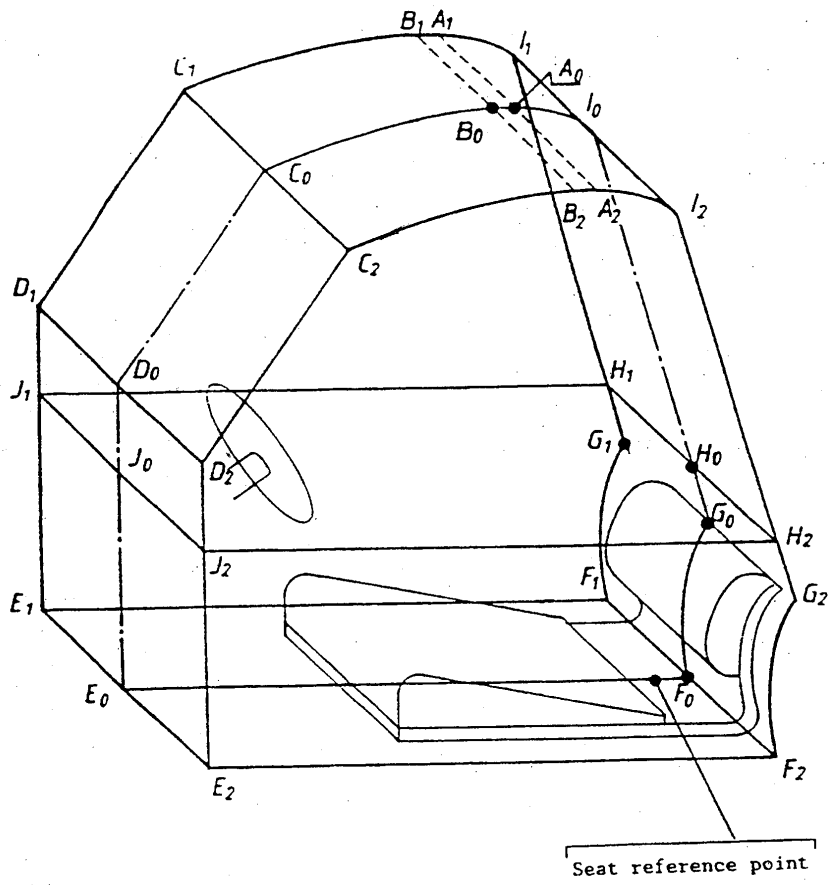

Figure 4.21
Clearance zone

Note: for dimensions, see Table 4.2

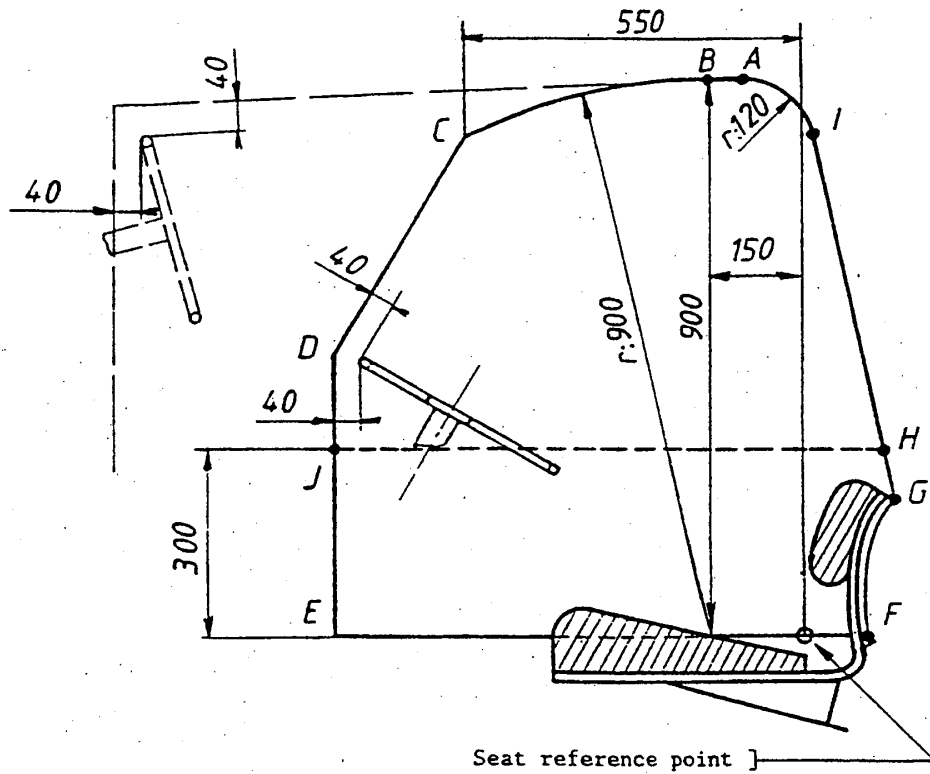

Figure 4.22

Clearance zone
side view

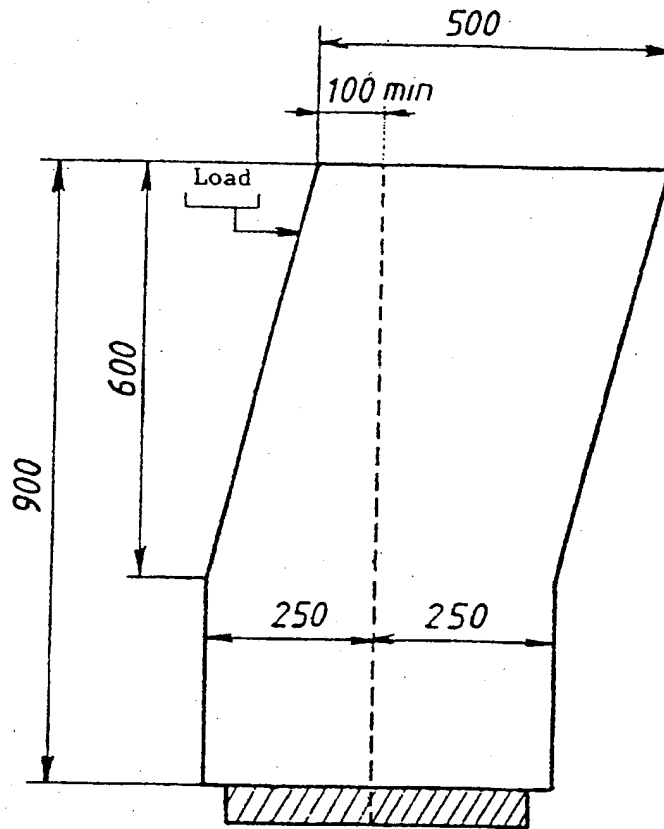

Figure 4.23

Clearance zone
rear / front view 150 mm from the seat reference point

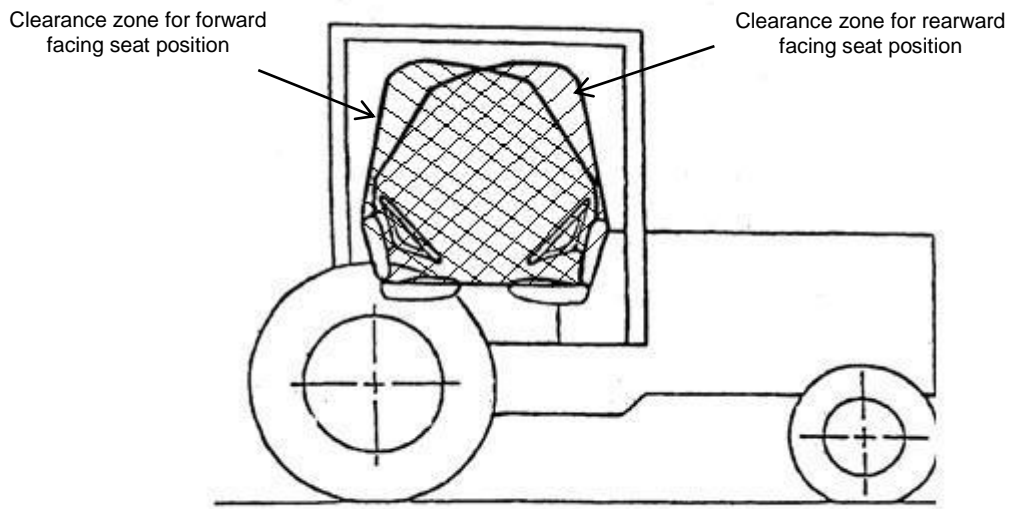

Figure 4.24.a Protective cab

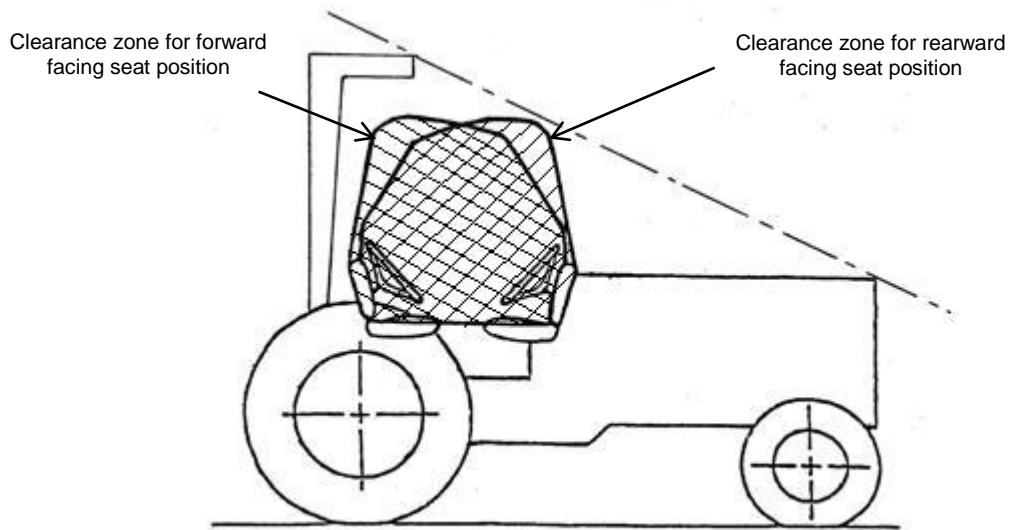

Figure 4.24.b Rear roll bar frame

Figure 4.24
Clearance zone for tractor with reversible seat and steering wheel,
protective cab and rear roll bar frame