

CODE 3

**OECD STANDARD CODE FOR THE
OFFICIAL TESTING OF PROTECTIVE STRUCTURES
ON AGRICULTURAL AND FORESTRY TRACTORS**

(DYNAMIC TEST)

TABLE OF CONTENTS

1. DEFINITIONS.....	3
1.1 Agricultural and forestry tractors.....	3
1.2 Track.....	3
1.3 Wheelbase.....	4
1.4 Determination of seat reference point; Seat location and adjustment for test.....	4
1.5 Clearance zone.....	4
1.6 Unballasted mass.....	6
1.7 Permissible measurement tolerances.....	6
1.8 Symbols.....	6
2. FIELD OF APPLICATION.....	6
3. RULES AND DIRECTIONS.....	6
3.1 General regulations.....	6
3.2 Apparatus and test conditions.....	7
3.3 Impact tests.....	8
3.4 Crushing tests.....	10
3.5 Conditions for acceptance.....	11
3.6 Extension to other tractor models.....	12
3.7 Labelling.....	13
3.8 Cold weather performance of protective structures.....	13
3.9 Seatbelt anchorage performance.....	15
SPECIMEN TEST REPORT.....	33
1. SPECIFICATION OF TEST TRACTOR.....	33
2. SPECIFICATION OF PROTECTIVE STRUCTURE.....	34
3. TEST RESULTS.....	36
SPECIMEN TECHNICAL EXTENSION REPORT.....	39
1. SPECIFICATION OF TEST TRACTOR.....	39
2. SPECIFICATION OF PROTECTIVE STRUCTURE.....	40
3. TEST RESULTS.....	42
SPECIMEN ADMINISTRATIVE EXTENSION REPORT.....	46

CODE 3

OECD STANDARD CODE FOR THE OFFICIAL TESTING OF PROTECTIVE STRUCTURES ON AGRICULTURAL AND FORESTRY TRACTORS (DYNAMIC TEST)

1. DEFINITIONS

1.1 *Agricultural and forestry tractors*

Self-propelled wheeled vehicles, having at least two axles, or with tracks, designed to carry out the following operations, primarily for agricultural and forestry purposes:

- to pull trailers;
- to carry, pull or propel agricultural and forestry tools or machinery and, where necessary, supply power to operate them with the tractor in motion or stationary.

1.2 *Track*

1.2.1 Preliminary definition: median plane of the wheel

The median plane of the wheel is equidistant from the two planes containing the periphery of the rims at their outer edges.

1.2.2 Definition of track

The vertical plane through the wheel axis intersects its median plane along a straight line which meets the supporting surface at one point. If **A** and **B** are the two points thus defined for the wheels on the same axle of the tractor, then the track width is the distance between points **A** and **B**. The track may be thus defined for both front and rear wheels. Where there are twin wheels, the track is the distance between two planes each being the median plane of the pairs of wheels.

For tracklaying tractors, the track is the distance between the median planes of the tracks.

1.2.3 Additional definition: median plane of the tractor

Take the extreme positions of points **A** and **B** for the tractor rear axle, which gives the maximum possible value for the track. The vertical plane at right angles to the line **AB** at its centre point is the median plane of the tractor.

1.3 *Wheelbase*

The distance between the vertical planes passing through the two lines **AB** as defined above, one for the front wheels and one for the rear-wheels.

1.4 Determination of seat reference point; Seat location and adjustment for test

1.4.1 Seat reference point

1.4.1.1 The reference must be established by means of the apparatus illustrated in figures 3.1, 3.2 and 3.3. The apparatus consists of a seat pan board and backrest boards. The lower backrest board is jointed in the region of the ischium humps (**A**) and loin (**B**), the joint (**B**) being adjustable in height.

1.4.1.2 The seat reference point is defined as the point in the median longitudinal plane of the seat where the tangential plane of the lower backrest and a horizontal plane intersect. This horizontal plane cuts the lower surface of the seat pan board 150 mm in front of the above-mentioned tangent.

1.4.1.3 The apparatus is positioned on the seat. It is then loaded with a force of 550 N at a point 50 mm in front of joint (**A**), and the two parts of the backrest board lightly pressed tangentially against the backrest.

1.4.1.4 If it is not possible to determine definite tangents to each area of the backrest (above and below the lumbar region), the following steps must be taken:

- where no definite tangent to the lower area is possible, the lower part of the backrest board is pressed against the backrest vertically;
- where no definite tangent to the upper area is possible, the point (**B**) is fixed at a height of 230 mm above the lower surface of the seat pan board, the backrest board being perpendicular to the seat pan board. Then the two parts of the backrest board are lightly pressed against the backrest tangentially.

1.4.2 Seat location and adjustment for test

1.4.2.1 where the seat position is adjustable, the seat must be adjusted to its rear uppermost position;

1.4.2.2 where the inclination of the backrest and seat pan is adjustable, these must be adjusted so that the reference point is in its rear uppermost position;

1.4.2.3 where the seat is equipped with suspension, the latter must be blocked at mid-travel, unless this is contrary to the instructions clearly laid down by the seat manufacturer;

1.4.2.4 where the position of the seat is adjustable only lengthwise and vertically, the longitudinal axis passing through the seat reference point shall be parallel with the vertical longitudinal plane of the tractor passing through the centre of the steering wheel and not more than 100 mm from that plane.

1.5 Clearance zone

1.5.1 Vertical reference plane

The clearance zone (figures 3.11 to 3.14 and table 3.3) is defined in relation to the vertical reference plane. The vertical plane, generally longitudinal to the tractor and passing through the seat reference point and the centre of the steering wheel. Normally the vertical reference plane coincides with the median plane of the tractor. This vertical reference plane shall be assumed to move horizontally with the seat and steering wheel during loading but to remain perpendicular to the tractor or the floor of the protective structure.

1.5.2 Determination of clearance zone

The clearance zone is defined as follows with the tractor standing on a horizontal surface and, where applicable, the steering wheel adjusted to the mid-position for seated driving:

1.5.2.1 A horizontal plane ($A_1 B_1 B_2 A_2$) 900 mm above the seat reference point;

1.5.2.2 An inclined plane ($G_1 G_2 I_2 I_1$) perpendicular to the reference plane and including both a point 900 mm directly above the seat reference point and the rearmost point of the seat backrest;

1.5.2.3 A cylindrical surface ($A_1 A_2 I_2 I_1$) perpendicular to the reference plane, with a radius of 120 mm, tangential to the planes defined in 1.5.2.1 and 1.5.2.2 above;

1.5.2.4 A cylindrical surface ($B_1 C_1 C_2 B_2$) perpendicular to the reference plane, having a radius of 900 mm extending forward for 400 mm and tangential to the plane defined in 1.5.2.1 above at a point 150 mm forward of the seat reference point;

1.5.2.5 An inclined plane ($C_1 D_1 D_2 C_2$) perpendicular to the reference plane, joining the surface defined in 1.5.2.4 above at its forward edge and passing 40 mm from the forward external edge of the steering wheel. In case of a high steering wheel position, this plane extends forward from $B_1 B_2$ tangentially to the surface under 1.5.2.4;

1.5.2.6 A vertical plane ($D_1 E_1 E_2 D_2$) perpendicular to the reference plane 40 mm forward of the external edge of the steering wheel (see 1.5.2.5 for the case of a high steering wheel position);

1.5.2.7 A horizontal plane ($E_1 F_1 F_2 E_2$) through the seat reference point;

1.5.2.8 A surface ($G_1 F_1 G_2 F_2$), if necessary curved, from the bottom limit of the plane defined in 1.5.2.2 above, to the horizontal plane defined in 1.5.2.7, perpendicular to the reference plane, and in contact with the seat backrest throughout its length;

1.5.2.9 Vertical planes ($J_1 E_1 F_1 G_1 H_1$) and ($J_2 E_2 F_2 G_2 H_2$). These vertical planes shall extend upwards from the seat reference point for 300 mm; the distances $E_1 E_0$ and $E_2 E_0$ shall be 250 mm;

1.5.2.10 Parallel planes ($A_1 B_1 C_1 D_1 J_1 H_1 I_1$) and ($A_2 B_2 C_2 D_2 J_2 H_2 I_2$) inclined so that the upper edge of the plane on the side on which the force is applied, is at least 100 mm from the vertical reference plane.

1.5.3 Tractors with a reversible driver's position

For tractors with a reversible driver's position (reversible seat and steering wheel), the clearance zone is the envelope of the two clearance zones defined by the two different positions of the steering wheel and the seat (figures 3.14a and 3.14b).

1.5.4 Optional seats

In case of tractors that could be fitted with optional seats, the envelope comprising the seat reference points of all the options offered shall be used during the tests. The protective structure shall not enter the larger clearance zone which takes account of these different seat reference points.

1.6 *Unballasted mass*

The mass of the tractor without ballasting devices and, in the case of tractors with pneumatic tyres, without liquid ballast in the tyres. The tractor shall be in running order with tanks, circuits and radiator full, protective structure with cladding and any track equipment or additional front wheel drive components required for normal use. The operator is not included.

1.7 *Permissible measurement tolerances*

Distance	± 0.5 %
Force	± 1.0 %
Mass	± 0.5 %
Tyre pressure	± 5.0 %

1.8 *Symbols*

E	(J)	Energy input during test
F	(N)	Static load force
H	(mm)	Height of lift of the centre of gravity of the pendulum block
I	(kg.m ²)	Moment of inertia about rear axle, excluding wheels used for calculating rear impact energy
L	(mm)	Wheelbase used for calculating rear impact energy
M	(kg)	Mass used for calculating energy and crushing forces

2. **FIELD OF APPLICATION**

2.1 This OECD Standard Code is applicable to tractors having at least two axles for pneumatic tyred wheels with or without track attachments and with an unballasted tractor mass greater than 600 kg but generally less than 6000 kg.

2.2 The minimum track width of the rear-wheels should generally be greater than 1 150 mm. It is recognised that there may be designs of tractors, for example, lawn mowers, narrow vineyard tractors, low profile tractors used in buildings with limited overhead clearance or in orchards, stilt tractors (high clearance) and special forestry machines, such as forwarders and skidders, for which this Standard Code is not applicable.

3. **RULES AND DIRECTIONS**

3.1 *General regulations*

3.1.1 The protective structure may be manufactured either by the tractor manufacturer or by an independent firm. In either case a test is only valid for the model of tractor on which it is carried out. The protective structure must be retested for each model of tractor to which it is to be fitted. However, testing stations may certify that the strength tests are also valid for tractor models derived from the original model by modifications to the engine, transmission and steering and front suspension (*see below 3.6: Extension to other tractor models*). On the other hand, more than one protective structure may be tested for any one model of tractor.

3.1.2 The protective structure submitted for dynamic test must be supplied attached in the normal manner to the tractor model in connection with which it is being tested. The tractor submitted shall be complete and in running order.

3.1.3 Where a "tandem" tractor is concerned, the mass of the standard version of that part to which the protective structure is fitted is to be used.

3.1.4 A protective structure may be designed solely to protect the driver in the event of the tractor overturning. Onto this structure it may be possible to fit weather protection for the driver, of a more or less temporary nature. The driver will usually remove this in warm weather. There are protective structures however, in which the cladding is permanent and warm weather ventilation provided by windows or flaps. As the cladding may add to the strength of the structure and if removable may well be absent when an accident occurs, all parts that can be so taken away by the driver will be removed for the purpose of the test. Doors, roof hatch and windows that can be opened shall be either removed or fixed in the open position for the test, so that they do not add to the strength of the protective structure. It shall be noted whether, in this position, they would create a hazard for the driver in the event of overturning.

Throughout the remainder of these rules, reference will only be made to testing the protective structure. It must be understood that this includes cladding not of a temporary nature.

A description of any temporary cladding supplied is to be included in the specifications. All glass or similar brittle material shall be removed prior to the test. Tractor and protective structure components which might sustain needless damage during the test and which do not affect the strength of the protective structure or its dimensions may be removed prior to the test if the manufacturer wishes. No repairs or adjustment may be carried out during the test.

3.1.5 Any component of the tractor contributing to the strength of the protective structure such as mudguards, which has been reinforced by the manufacturer, should be described and its measurements given in the test report.

3.2 Apparatus and test conditions

3.2.1 The structure shall be struck by a block acting as a pendulum and submit to a front and a rear crushing test.

3.2.2 The mass of the pendulum bloc (figure 3.4) shall be 2 000 kg. Its impact face shall have dimensions 680 x 680 mm \pm 20. It shall be made in such a way that the position of its centre of gravity is constant (for example with iron bars bound in concrete). It shall be suspended from a pivot point about 6 m above the floor in such a way that the height of the pendulum may be conveniently and safely adjusted.

3.2.3 For tractors with less than 50 per cent of their mass on the front wheels, the first blow shall be at the rear of the structure. This shall be followed by a crushing test also at the rear of the structure. The second blow shall be at the front and the third at the side. Finally, there shall be a second crushing test at the front.

For tractors with 50 per cent or more of their mass on the front wheels, the first blow shall be at the front and the second blow at the side. This shall be followed by the two crushing tests, firstly at the rear and secondly at the front.

3.2.4 For tractors with a reversible driver's position (reversible seat and steering wheel), the first blow shall be longitudinal at the heavier end (with more than 50 per cent of the mass of the tractor). This shall be followed by a crushing test on the same end. The second blow shall be at the other end, and the third at the side. Finally, there shall be a second crushing test at the lighter end.

3.2.5 A track width setting for the rear-wheels shall be chosen such that the structure is in no way supported by the tyres during the test. This provision may be disregarded if such support is given when the wheels are in their widest alternative track setting.

3.2.6 The side of the tractor from which the side blow is struck shall be that which, in the opinion of the testing station, is likely to give the greatest distortion. The rear blow shall be on the corner opposite the side blow and the front blow on the corner nearer the side blow. The rear blow shall be administered at two-thirds the distance from the median plane of the tractor to the vertical plane touching the outside extremity of the structure. However, if a curve in the back of the structure starts at less than two-thirds of the distance from the centre, the blow shall be struck at the beginning of the curve, i.e. at the point where this curve is tangential to a line at right angles to the median plane of the tractor.

3.2.7 If, during the test, any lashings, props or blocks move or break, the test must be repeated.

3.3 *Impact tests*

3.3.1 Impact at the rear [figures 3.5(a) and 3.5(b)]

3.3.1.1 The rear impact is not required on tractors having 50 per cent or more of their mass (as defined above) on the front wheels.

3.3.1.2 The tractor shall be placed in relation to the pendulum so that this will strike the structure when the striking face and the supporting chains are at an angle of 20° to the vertical unless the structure at the point of contact has, during deflection, a greater angle with the vertical. In this case the striking face shall be adjusted parallel to the side of the structure at the point of contact at the moment of maximum deflection by an additional support, the supporting chains remaining at an angle of 20° to the vertical. The point of impact shall be that part of the structure likely to hit the ground first in a rearward overturning accident, normally the upper edge. The height of the pendulum will be so adjusted that it has no tendency to turn about the point of contact.

3.3.1.3 The tractor will be lashed down. The points of attachment of the lashings shall be approximately 2 m behind the rear axle and 1.5 m in front of the front axle. There shall be two lashings on each axle, one on each side of the median plane of the tractor. The lashings shall be steel cable of 12.5 to 15 mm diameter, tensile strength 1 100 - 1 260 MPa. The tyres of the tractor shall be inflated, and the lashings tightened to give tyre pressures and deflections, as shown in the table 3.1, below.

After the lashings have been tightened a wood beam 150x150 mm shall be clamped in front of the rear-wheels, driven tight against them.

3.3.1.4 The pendulum shall be pulled back so that the height H of its centre of gravity above that at the point of impact is given by one of the following formulae at the option of the manufacturer:

$$H = 2.165 \times 10^{-8} ML^2 \quad \text{or} \quad H = 5.73 \times 10^{-2} I$$

3.3.1.5 The pendulum shall be released and allowed to crash against the structure. The quick release mechanism must be so positioned that it does not tilt the weight in relation to the chains supporting it at the moment of release.

	Tyre pressures kPa (*)	Deflection mm
Four-wheel drive tractors with front and rear wheels of the same size:		
Front	100	25
Rear	100	25
Four-wheel drive tractors with front wheels smaller than rear wheels:		
Front	150	20
Rear	100	25
Two-wheel drive tractors:		
Front	200	15
Rear	100	25
(*) No water ballast is to be used		

Table 3.1
Tyre Pressures

3.3.2 Impact at the front [figures 3.6(a) and 3.6(b)]

3.3.2.1 This shall be carried out in the same way as the impact at the rear. The lashings shall be the same but the wooden beam shall be behind the rear-wheels. The height of fall of the centre of gravity of the pendulum shall be given by the following formula:

$$H = 125 + 0.02 M$$

3.3.2.2. The point of impact shall be that part of the structure that would hit the ground first when turning over sideways while travelling forward, normally the top of the front corner.

3.3.3 Impact at the side [figure 3.7]

3.3.3.1 The tractor shall be placed in relation to the pendulum so that this will strike the structure when the striking face and the supporting chains are vertical unless the structure at the point of contact is, during deflection, other than vertical. In this case the striking face shall be adjusted so that it is approximately parallel to the structure at the point of contact at the moment of maximum deflection. This adjustment shall be made by an additional support, the supporting chains remaining vertical at the moment of impact. The point of impact shall be that part of the structure likely to hit the ground first in a sideways overturning accident, normally the upper edge.

3.3.3.2 Unless it is certain that any other part of this edge would hit the ground first, the point of impact shall be in the plane at right angles to the median plane of the tractor and 200 mm forward of the seat reference point, the seat being at its mid-point of adjustment. The height of the pendulum will be so adjusted that it has no tendency to turn about the point of contact.

3.3.3.3 For tractors with a reversible driver's position, the point of impact shall be in the plane at right angles to the median plane of the tractor and at the mid-point between the two seat reference points.

3.3.3.4 The rear-wheel of the tractor on the side to be struck shall be lashed down. The tension in the lashings shall be determined as for the impact at the rear. After lashing, a beam 150 x 150 mm shall be clamped against the side of the rear-wheel opposite the blow, and driven hard against the tyre. A beam shall be placed as a prop against this wheel and secured on the floor so that it is held tight against the wheel during impact. The length of this beam shall be chosen so that when in position against the wheel it makes an angle of 25 to 40° with the horizontal. Furthermore its length shall be 20 to 25 times its thickness and its width 2 to 3 times its thickness.

3.3.3.5 The pendulum shall be pulled back as in the previous tests so that the height **H** of its centre of gravity above that at the moment of impact is determined by the following formula:

$$H = 125 + 0.15 M.$$

3.3.3.6 During the side impact test the difference between the maximum momentary deflection and the residual deflection at a height of 900 mm above the seat reference point shall be recorded. This may be done with a device on which a moving friction collar shall be fitted on a horizontal rod. One end of the rod shall be attached to the top member of the structure and the other will pass through a hole in a vertical bar attached to tractor chassis. The collar will be positioned against the vertical bar attached to tractor chassis before the blow and its distance from it after the blow will give the difference between the maximum momentary deflection and the residual deflection.

3.4 *Crushing tests*

It may be necessary to hold down the front of the tractor when carrying out the test at the rear. Blocks will be placed under the axles so that the tyres do not bear crushing force. The cross beam used shall have a width of approximately 250 mm and shall be connected to the load applying mechanism by universal joints. (figure 3.8)

3.4.1 Crushing at the rear [figures 3.9(a) and 3.9(b)]

3.4.1.1 The crushing beam shall be positioned across the rear uppermost structural members so that the resultant of the crushing forces is located in the vertical reference plane. The crushing force (**F**) shall be applied where:

$$F = 20 M.$$

This force shall be maintained for 5 seconds after cessation of any visually detectable movement of the protective structure.

3.4.1.2 Where the rear part of the protective structure roof will not sustain the full crushing force [figures 3.10(a) and 3.10(b)], the force shall be applied until the roof is deflected to coincide with the plane joining the upper part of the protective structure with that part of the rear of the tractor capable of supporting the tractor when overturned.

The force shall then be removed and the crushing beam repositioned over that part of the protective structure that would support the tractor when completely overturned. The crushing force **F** shall be applied.

3.4.2 Crushing at the front [figures 3.9(a) and 3.9(b)]

3.4.2.1 The crushing beam shall be positioned across the front uppermost structural members so that the resultant of the crushing forces is located in the vertical reference plane. The crushing force (**F**) shall be applied where:

$$F = 20 M.$$

This force shall be maintained for 5 seconds after cessation of any visually detectable movement of the protective structure.

3.4.2.2 When the front part of the roof of the protective structure will not sustain the full crushing force [figures 3.10(a) and 3.10(b)], the force shall be applied until the roof is deflected to coincide with the plane joining the upper part of the protective structure with that part of the front of the tractor capable of supporting the tractor when overturned.

The force shall then be removed and the crushing beam repositioned over that part of the protective structure that would support the tractor when completely overturned. The crushing force **F** shall then be applied.

3.5 Conditions for acceptance

3.5.1 The structure and tractor shall be visually examined for cracks and tears after each part of the test. For the structure to pass the test the following conditions shall be complied with:

3.5.1.1 there shall be no cracks in structural members, mounting components or tractor parts contributing to the strength of the protective structure (except as covered by 3.5.1.3 below);

3.5.1.2 there shall be no cracks in welds contributing to the strength of the protective structure or its mounting components. Spot or tack welding used for the attachment of cladding panels shall normally be excluded from this condition;

3.5.1.3 energy-absorbing tears in sheet metal structures are acceptable, providing that they are judged by the testing station to have not significantly reduced the resistance to deflection of the protective structure. Tears in sheet metal components caused by edges of the pendulum weight shall be ignored;

3.5.1.4 the required force must be sustained in both crushing tests;

3.5.1.5 the difference between the maximum momentary deflection and the residual deflection in the side impact test must not exceed 250 mm (figure 3.15);

3.5.1.6 no part shall enter the clearance zone during any part of the tests. No part may strike the seat during the tests. Furthermore, the clearance zone shall not be outside the protection of the protective structure. For this purpose, it shall be considered to be outside the protection of the structure if any part of it would come in contact with flat ground if the tractor overturned towards the direction from which the test load is applied. For estimating this, the tyres and track width setting shall be the smallest standard fitting specified by the manufacturer.

3.5.1.7 for the articulated tractors, the median planes of the two parts shall be assumed to be in line.

3.5.2 After the final crushing test the permanent deformation of the protective structure shall be recorded. For this purpose, before the start of the test, the position of the main members in relation to the

seat reference point must be recorded. Then any movement of the members struck in the tests and any change of the height of the front and back members of the roof shall be recorded.

3.6 *Extension to other tractor models*

3.6.1 Administrative extension

If there are changes in the make, denomination or marketing features of the tractor or protective structure tested or listed in the original test report, the testing station that has carried out the original test can issue an "administrative extension report". This extension report shall contain a reference to the original test report.

3.6.2 Technical extension

When technical modifications occur on the tractor, the protective structure or the method of attachment of the protective structure to the tractor, the testing station that has carried out the original test can issue a "technical extension report" in the following cases:

3.6.2.1 Extension of the structural test results to other models of tractors

The impact and crushing tests need not be carried out on each model of tractor, provided that the protective structure and tractor comply with the conditions referred to hereunder 3.6.2.1.1 to 3.6.2.1.5.

3.6.2.1.1 The structure shall be identical to the one tested;

3.6.2.1.2 The required energy shall not exceed the energy calculated for the original test by more than 5 per cent. The 5 per cent limit shall also apply to extensions in the case of substituting tracks for wheels on the same tractor;

3.6.2.1.3 The method of attachment and the tractor components to which the attachment is made shall be identical;

3.6.2.1.4 Any components such as mudguards and bonnet that may provide support for the protective structure shall be identical;

3.6.2.1.5 The position and critical dimensions of the seat in the protective structure and the relative position of the protective structure on the tractor shall be such that the clearance zone would have remained within the protection of the deflected structure throughout all tests.

3.6.2.2 Extension of the structural test results to modified models of the protective structure

This procedure has to be followed when the provisions of paragraph 3.6.2.1 are not fulfilled, it may not be used when the method of attachment of the protective structure to the tractor does not remain of the same principle (e.g. rubber supports replaced by a suspension device):

3.6.2.2.1 Modifications having no impact on the results of the initial test (e.g. weld attachment of the mounting plate of an accessory in a non-critical location on the structure), addition of seats with different SRP location in the protective structure (subject to checking that the new clearance zone(s) remain(s) within the protection of the deflected structure throughout all tests).

3.6.2.2.2 Modifications having a possible impact on the results of the original test without calling into question the acceptability of the protective structure (e.g. modification of a structural component,

modification of the method of attachment of the protective structure to the tractor). A validation test can be carried out and the test results will be drafted in the extension report.

The following limits for this type extension are fixed:

3.6.2.2.2.1 no more than 5 extension may be accepted without a validation test;

3.6.2.2.2.2 the results of the validation test will be accepted for extension if all the acceptance conditions of the Code are fulfilled and if the deflection measured after each impact test does not deviate from the deflection measured after each impact test in the original test report by more than $\pm 7\%$;

3.6.2.2.2.3 more than one protective structure modifications may be included in a single extension report if they represent different options of the same protective structure, but only one validation test can be accepted in a single extension report. The options not tested shall be described in a specific section of the extension report.

3.6.2.2.3 Increase of the reference mass declared by the manufacturer for a protective structure already tested. If the manufacturer wants to keep the same approval number it is possible to issue an extension report after having carried out a validation test (the limits of $\pm 7\%$ specified in 3.6.2.2.2.2 are not applicable in such a case).

3.7 Labelling

3.7.1 OECD labelling is optional. If it is utilised, it shall contain at least the following information:

3.7.1.1 name and address of the manufacturer of the protective structure;

3.7.1.2 protective structure identification number (design or serial number);

3.7.1.3 tractor make, model(s) or series number(s) that the protective structure is designed to fit;

3.7.1.4 OECD approval number of test report

3.7.2 The label shall be durable and permanently attached to the protective structure such that it can be easily read and it shall be protected from environmental damage.

3.8 Cold weather performance of protective structures

3.8.1 If the protective structure is claimed to have properties resistant to cold weather embrittlement, the manufacturer shall give details that shall be included in the report.

3.8.2 The following requirements and procedures are intended to provide strength and resistance to brittle fracture at reduced temperatures. It is suggested that the following minimum material requirements shall be met in judging the protective structure's suitability at reduced operating temperatures in those countries requiring this additional operating protection.

3.8.2.1 Bolts and nuts used to attach the protective structure to the tractor and used to connect structural parts of the protective structure shall exhibit suitable controlled reduced temperature toughness properties.

3.8.2.2 All welding electrodes used in the fabrication of structural members and mounts shall be compatible with the protective structure material as given in 3.8.2.3 below.

3.8.2.3 Steel materials for structural members of the protective structure shall be of controlled toughness material exhibiting minimum Charpy V-Notch impact energy requirements as shown in Table 3.2. Steel grade and quality shall be specified in accordance with ISO 630:1995; Amd1:2003

Steel with an as-rolled thickness less than 2.5 mm and with a carbon content less than 0.2 per cent is considered to meet this requirement. Structural members of the protective structure made from materials other than steel shall have equivalent low temperature impact resistance.

3.8.2.4 When testing the Charpy V-Notch impact energy requirements, the specimen size shall be no less than the largest of the sizes stated in Table 3.2 that the material will permit.

3.8.2.5 The Charpy V-Notch tests shall be made in accordance with the procedure in ASTM A 370-1979, except for specimen sizes that shall be in accordance with the dimensions given in Table 3.2.

3.8.2.6 Alternatives to this procedure are the use of killed or semi-killed steel for which an adequate specification shall be provided. Steel grade and quality shall be specified in accordance with ISO 630:1995; Amd1:2003

3.8.2.7 Specimens are to be longitudinal and taken from flat stock, tubular or structural sections before forming or welding for use in the protective structure. Specimens from tubular or structural sections are to be taken from the middle of the side of greatest dimension and shall not include welds.

Specimen size	Energy at -30 °C	Energy at -20 °C
mm	J	J ^{b)}
10 x 10 ^{a)}	11	27.5
10 x 9	10	25
10 x 8	9.5	24
10 x 7,5 ^{a)}	9.5	24
10 x 7	9	22.5
10 x 6,7	8.5	21
10 x 6	8	20
10 x 5 ^{a)}	7.5	19
10 x 4	7	17.5
10 x 3,5	6	15
10 x 3	6	15
10 x 2,5 ^{a)}	5.5	14

Table 3.2
Minimum Charpy V-notch impact energies

- a) Indicates preferred size. Specimen size shall be no less than largest preferred size that the material permits.
- b) The energy requirement at -20 °C is 2.5 times the value specified for -30 °C. Other factors affect impact energy strength, i.e. direction of rolling, yield strength, grain orientation and welding. These factors shall be considered when selecting and using steel.

3.9 *Seatbelt anchorage performance (Optional)*

3.9.1 Scope

Seat belts are one of the operator restraint systems used for securing the driver in motor vehicles.

This recommended procedure provides minimum performance and tests requirements for anchorage for agricultural and forestry tractors.

It applies to the anchorage of pelvic restraint systems.

3.9.2 Explanation of terms used in the performance testing

3.9.2.1 The *seat belt assembly* is any strap or belt device fastened across the lap or pelvic girdle area designed to secure a person in a machine.

3.9.2.2 The *extension belt* is intended as any strap, belt, or similar device that aids in the transfer of seat belt loads.

3.9.2.3 The *anchorage* is intended as the point where the seat belt assembly is mechanically attached to the seat system or tractor.

3.9.2.4 The *seat mounting* is intended as all intermediary fittings (such as slides, etc.) used to secure the seat to the appropriate part of the tractor.

3.9.2.5 The *Operator Restraint System* is intended as the total system composed of seat belt assembly, seat system, anchorages and extension which transfers the seat belt load to the tractor.

3.9.2.6 *Applicable Seat Components* comprise all components of the seat whose mass could contribute to loading of the seat mounting (to the vehicle structure) during a roll-over event.

3.9.3 Test procedure

Only static tests for anchorages are given in this procedure.

The seat shall be in position during the tests and fixed to the mounting point on the tractor using all intermediary fittings (such as suspension, slides, etc.) specified for the complete tractor. No additional non-standard fittings contributing to the strength of the construction may be used.

The anchorages shall be capable of withstanding the loads applied to the seat belt system using a device as shown in Figure 3.16. The seat belt anchorages shall be capable of these test loads applied with the seat adjusted in the worst position of the longitudinal adjustment to ensure that the test condition is met. The test loads shall be applied with the seat in the mid-position of the longitudinal adjustment if a worst position among the possible seat adjustments is not recognised by the testing station. For a suspended seat, the seat shall be set to the midpoint of the suspension travel, unless this is contradictory to a clearly stated instruction by the seat manufacturer. Where special instructions exist for the seat setting, these shall be observed and specified in the report. After the load is applied to the seat system, the load application device shall not be repositioned to compensate for any changes that may occur to the load application angle.

3.9.3.1 Forward loading

A tensile force shall be applied in a forward and upward direction at an angle of $45^\circ \pm 2^\circ$ to the horizontal, as shown in Figure 3.17. The anchorages shall be capable of withstanding a force of 4 450 N. In the event that the force applied to the seat belt assembly is transferred to the vehicle chassis by means of the seat, the seat mounting shall be capable of withstanding this force plus an additional force equal to four times the force of gravity on the mass of all applicable seat components, applied $45^\circ \pm 2^\circ$ to the horizontal in a forward and upward direction, as shown in Figure 3.17.

3.9.3.2 Rearward loading

A tensile force shall be applied in a rearward and upward direction at an angle of $45^\circ \pm 2^\circ$ to the horizontal, as shown in Figure 3.18. The anchorages shall be capable of withstanding a force of 2 225 N. In the event that the force applied to the seat belt assembly is transferred to the vehicle chassis by means of the seat, the seat mounting shall be capable of withstanding this force plus an additional force equal to two times the force of gravity on the mass of all applicable seat components, applied $45^\circ \pm 2^\circ$ to the horizontal in a rearward and upward direction, as shown in Figure 3.18. Both tensile forces shall be equally divided between the anchorages.

3.9.4 Test result

Condition of acceptance

Permanent deformation of any system component and anchorage area is acceptable under the action of the forces specified in 3.9.3.1 and 3.9.3.2. However, there shall be no failure allowing release of the seat belt system, seat assembly, or the seat adjustment locking mechanism.

The seat adjuster or locking device need not be operable after application of the test load.

The results of a test performed on an identical “operator restraint system” may be included in more than one test report provided that this system is fitted exactly in the same conditions.

The results of a test performed after the approval of the test report of the protective structure shall be drafted in a technical extension report.

Dimensions in mm

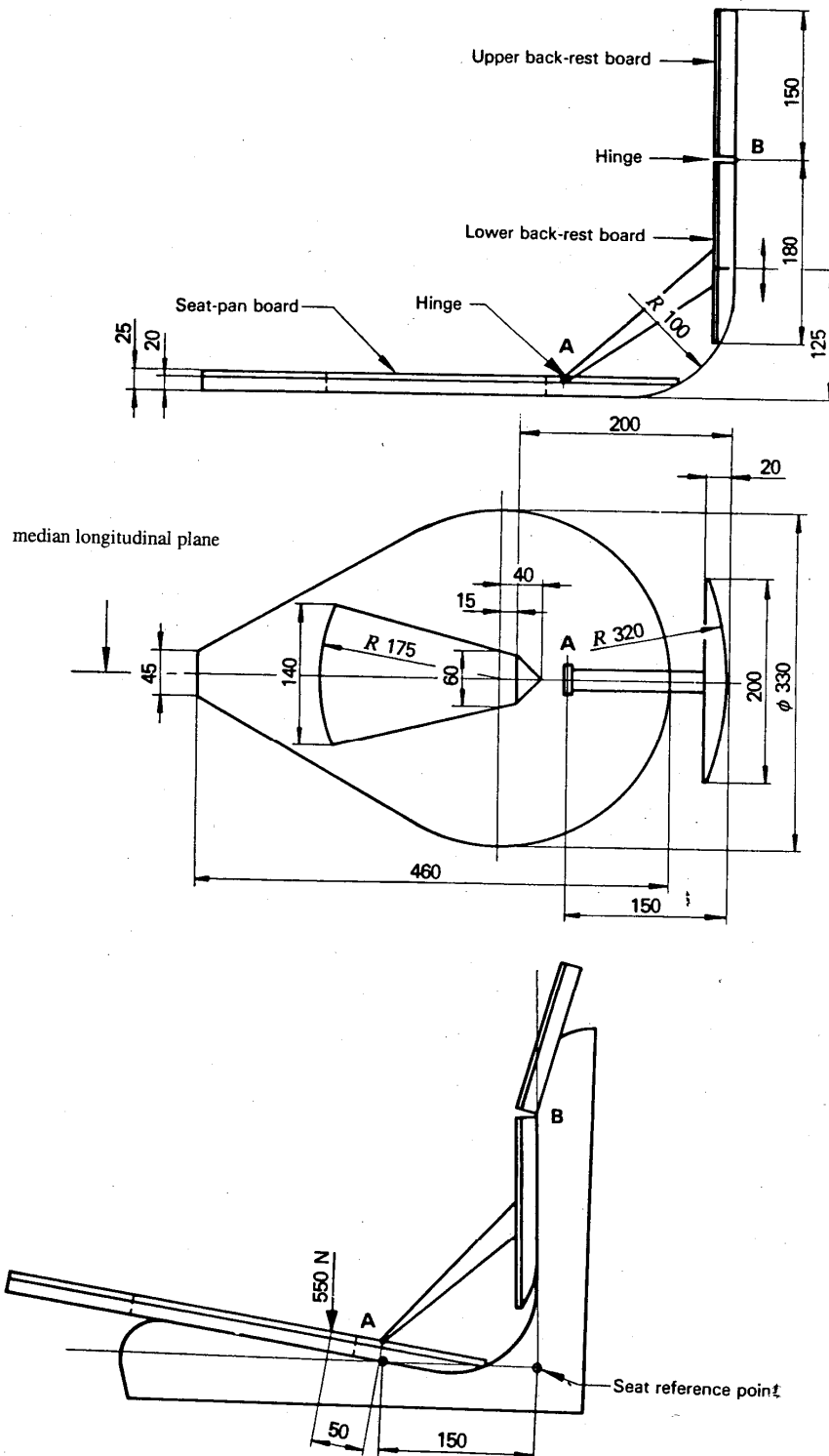

Figures 3.1, 3.2 and 3.3

Apparatus for determination of seat reference point

Dimensions in mm

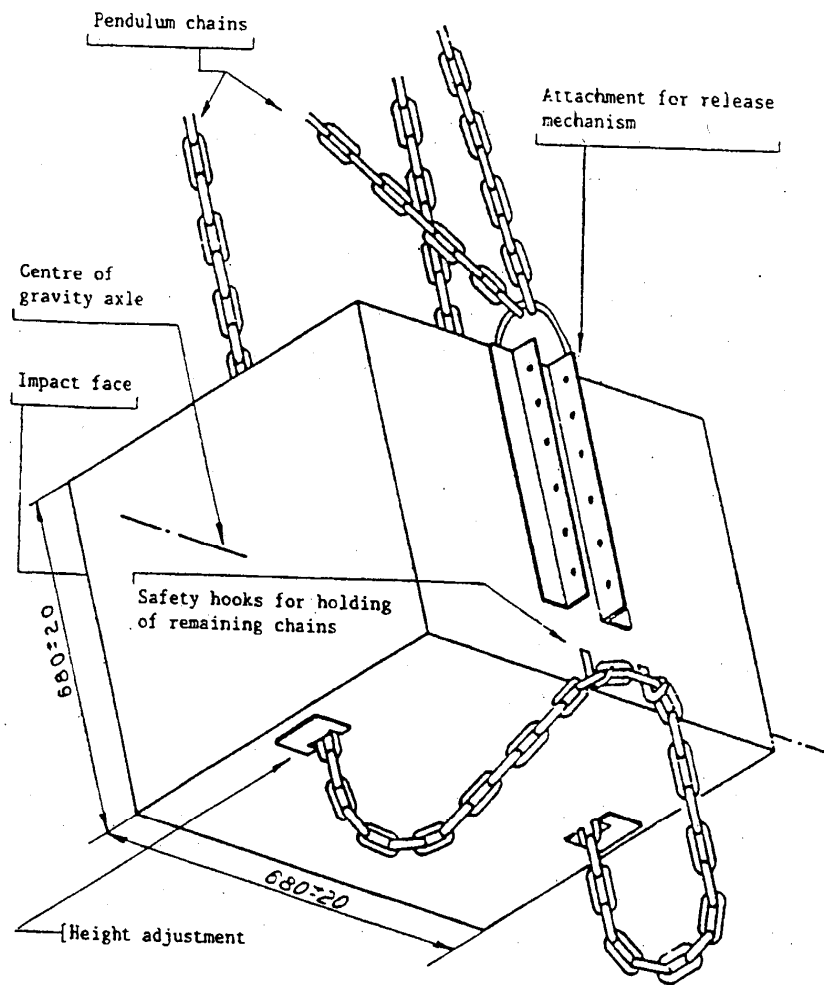

Figure 3.4

Pendulum block and its suspending chains or wire ropes

Dimensions in mm

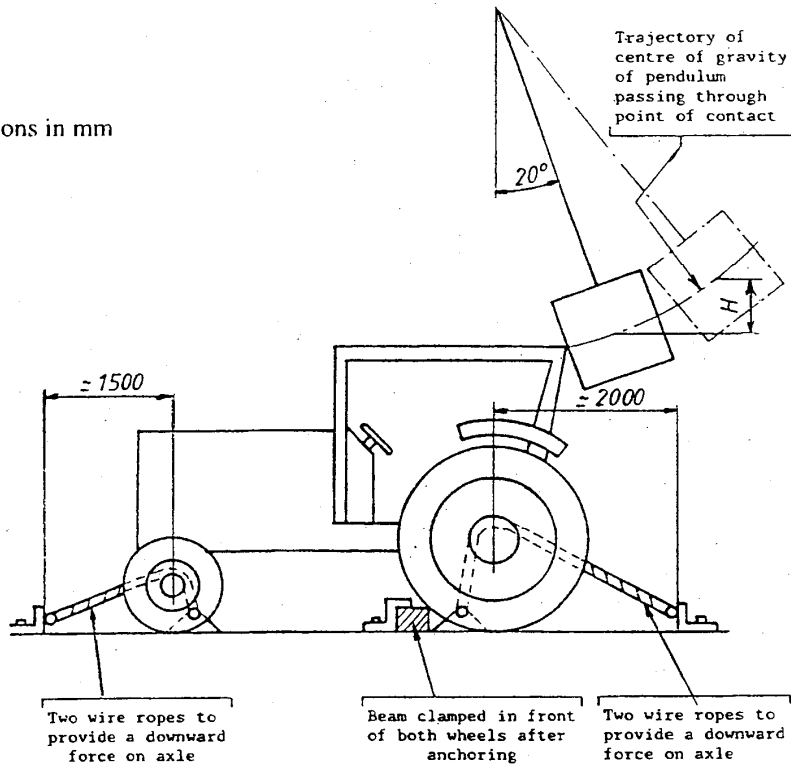

Figure 3.5(a): Protective cab

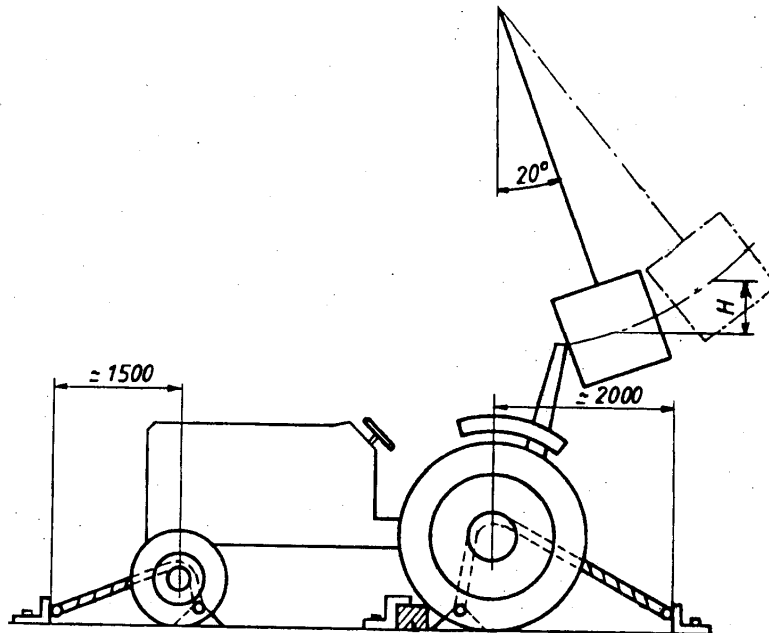

Figure 3.5(b): Rear roll bar frame
Method of impact from rear
for protective cab and rear roll bar frame

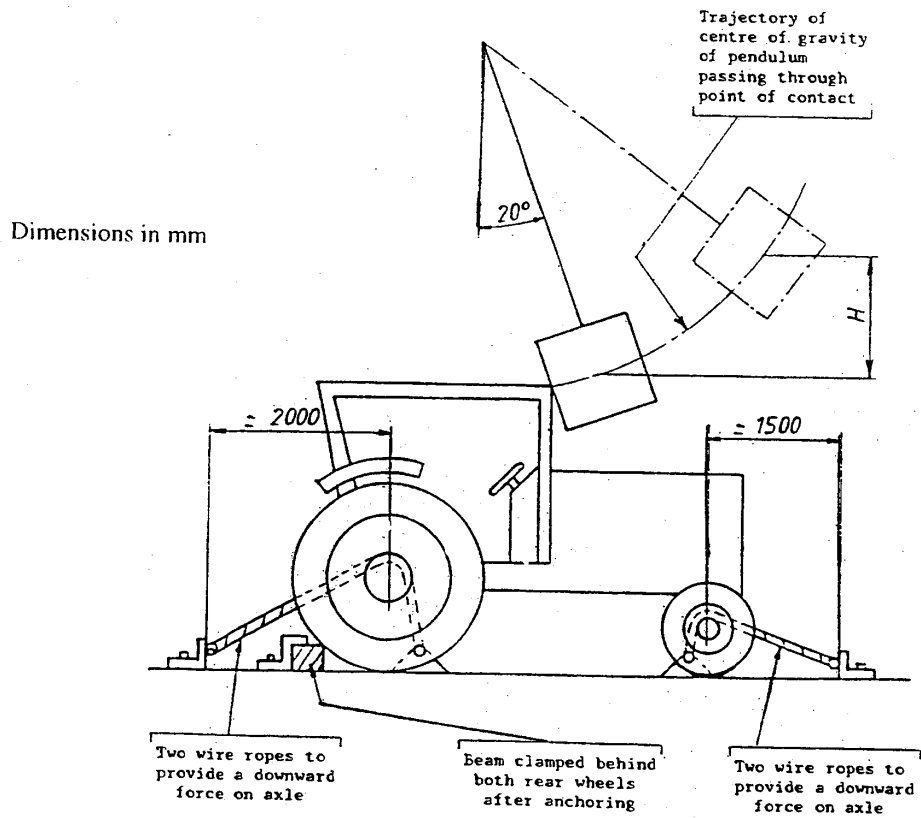

Figure 3.6(a): Protective cab

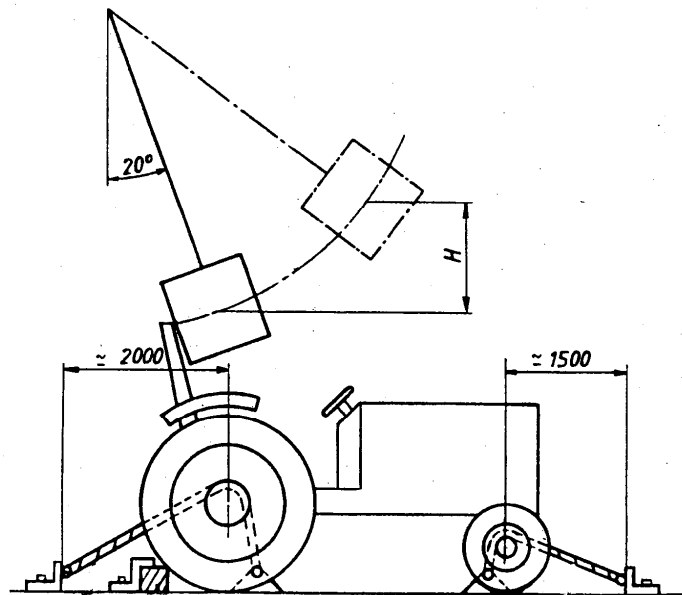

Figure 3.6(b): Rear roll bar frame

Method of impact from front
for protective cab and rear roll bar frame

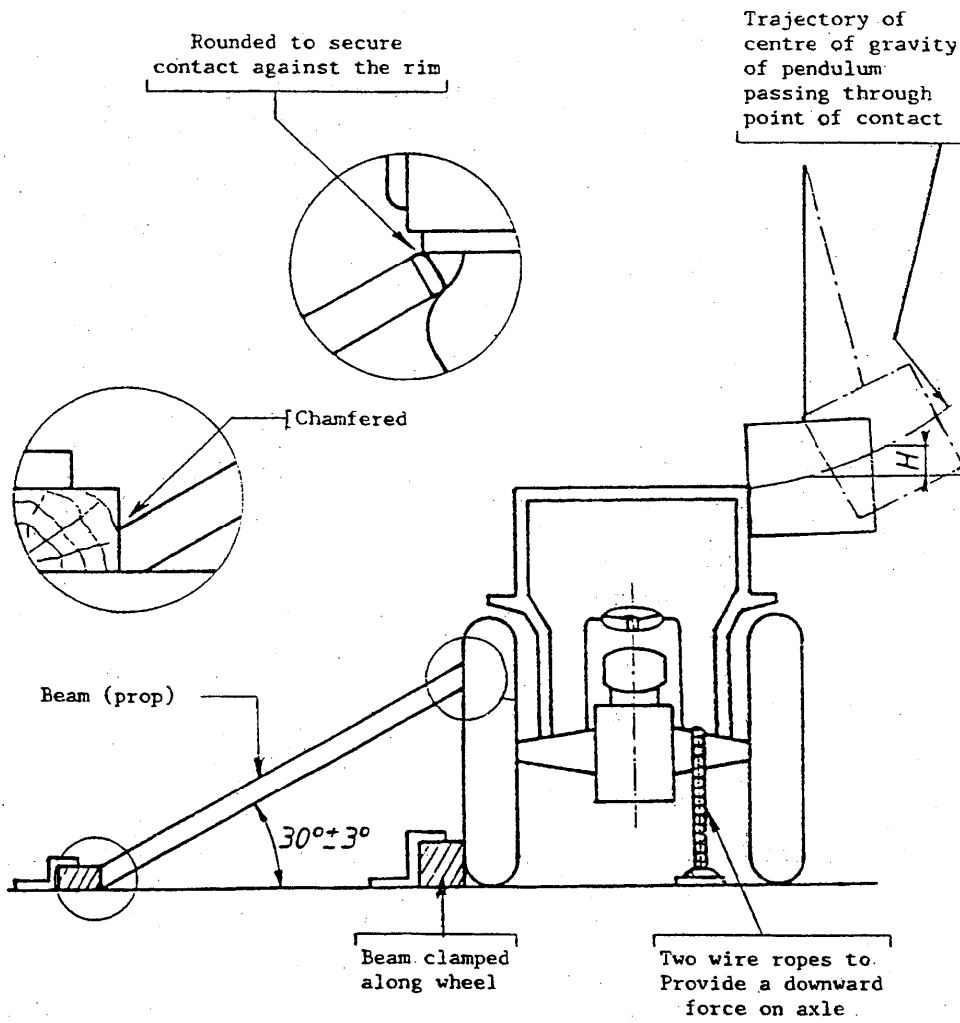

Figure 3.7
Method of impact from side

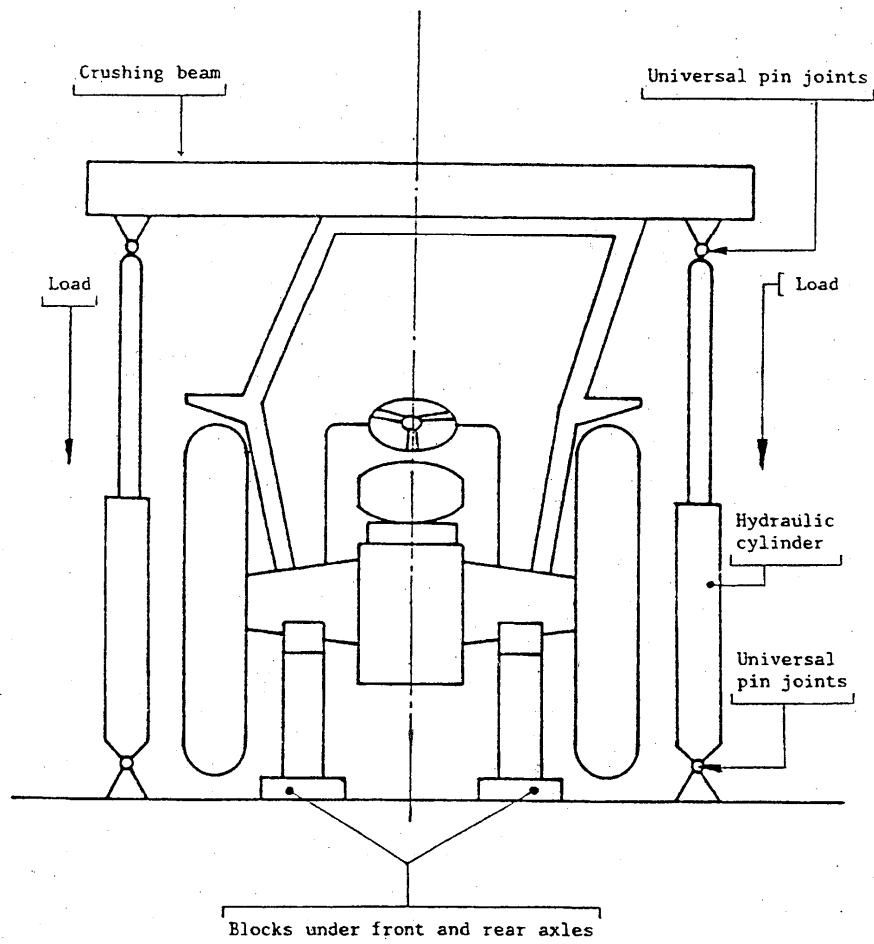

Figure 3.8

Example of an arrangement for crushing tests

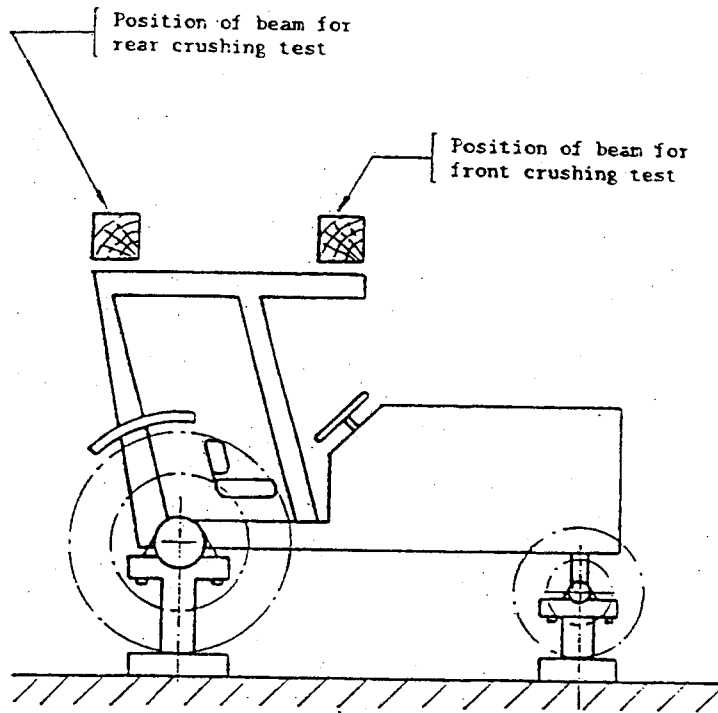

Figure 3.9(a): Protective cab

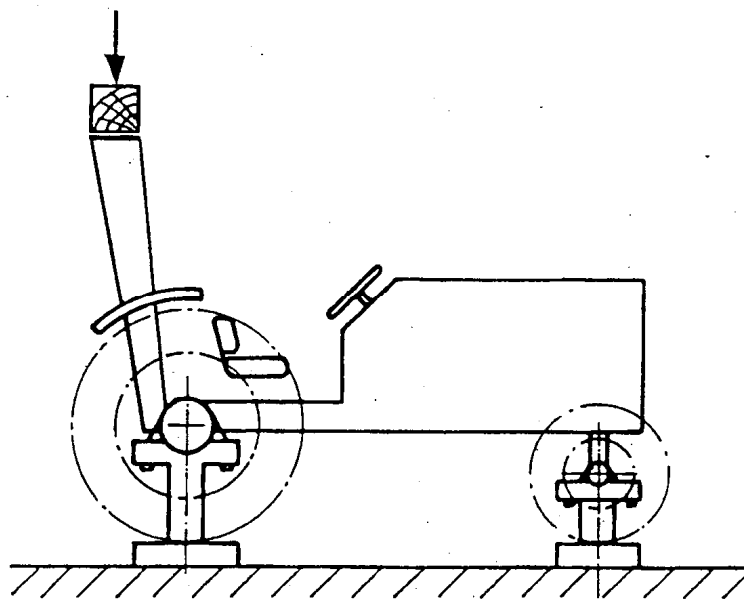

Figure 3.9(b): Rear roll bar frame

**Position of beam for front and rear crushing tests
for protective cab and rear roll bar frame**

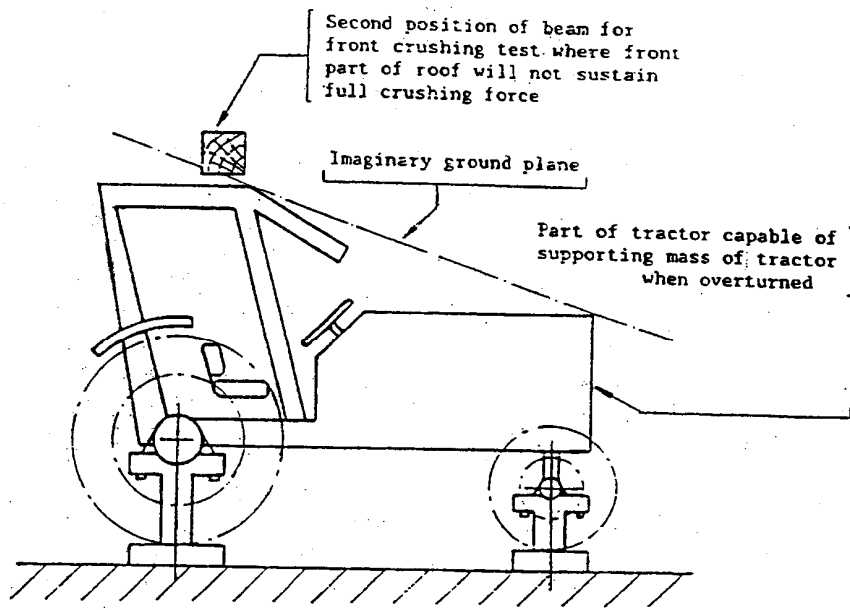

Figure 3.10(a): Protective cab

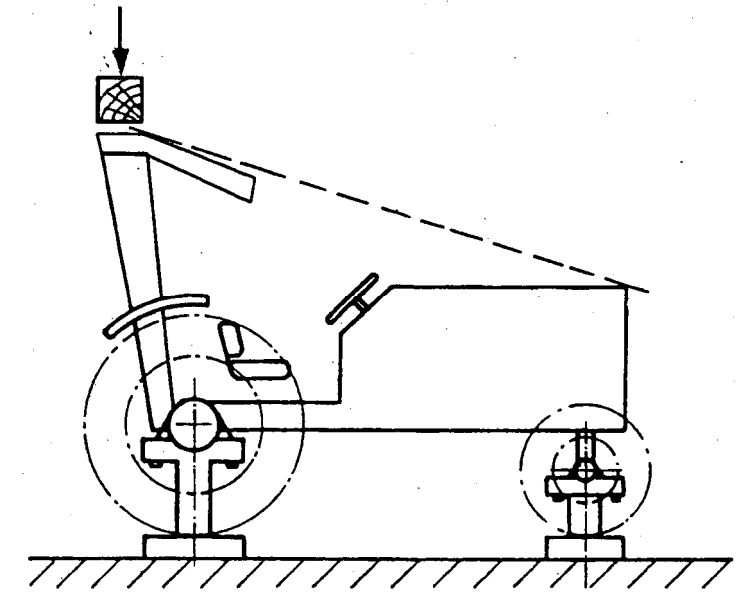

Figure 3.10(b): Rear roll bar frame

**Position of beam for front crushing test
when full crushing force not sustained in front**

Dimensions	mm	Remarks
A ₁ A ₀	100	minimum
B ₁ B ₀	100	minimum
F ₁ F ₀	250	minimum
F ₂ F ₀	250	minimum
G ₁ G ₀	250	minimum
G ₂ G ₀	250	minimum
H ₁ H ₀	250	minimum
H ₂ H ₀	250	minimum
J ₁ J ₀	250	minimum
J ₂ J ₀	250	minimum
E ₁ E ₀	250	minimum
E ₂ E ₀	250	minimum
D ₀ E ₀	300	minimum
J ₀ E ₀	300	minimum
A ₁ A ₂	500	minimum
B ₁ B ₂	500	minimum
C ₁ C ₂	500	minimum
D ₁ D ₂	500	minimum
I ₁ I ₂	500	minimum
F ₀ G ₀	-	depending on the tractor
I ₀ G ₀	-	
C ₀ D ₀	-	
E ₀ F ₀	-	

Table 3.3

Dimensions of the clearance zone

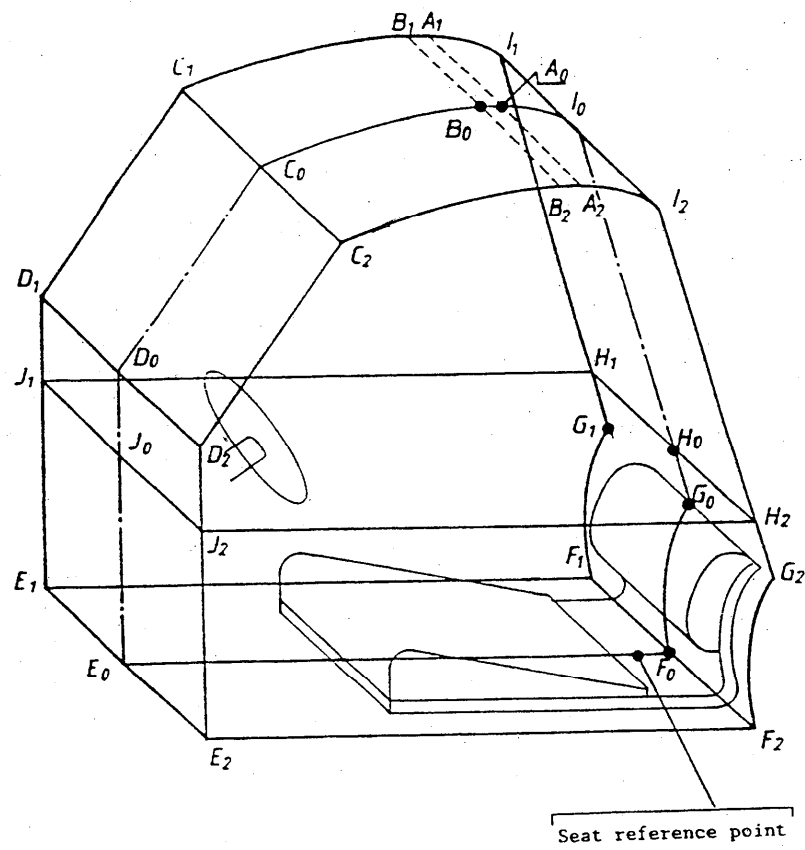

Figure 3.11

Clearance zone

Note: for dimensions, see table 3.3 above

Dimensions in mm

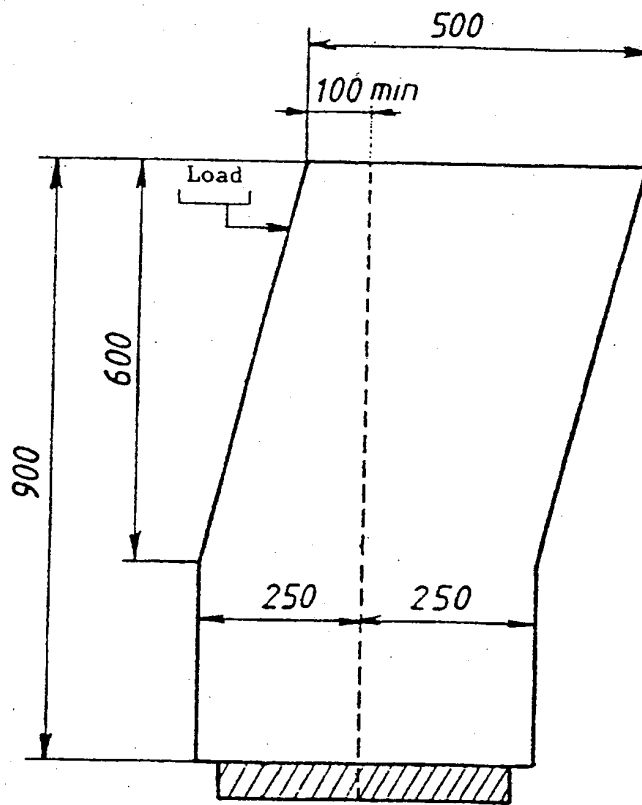

Figure 3.13

Clearance zone - rear / front view 150 mm from the seat reference point

Dimensions in mm

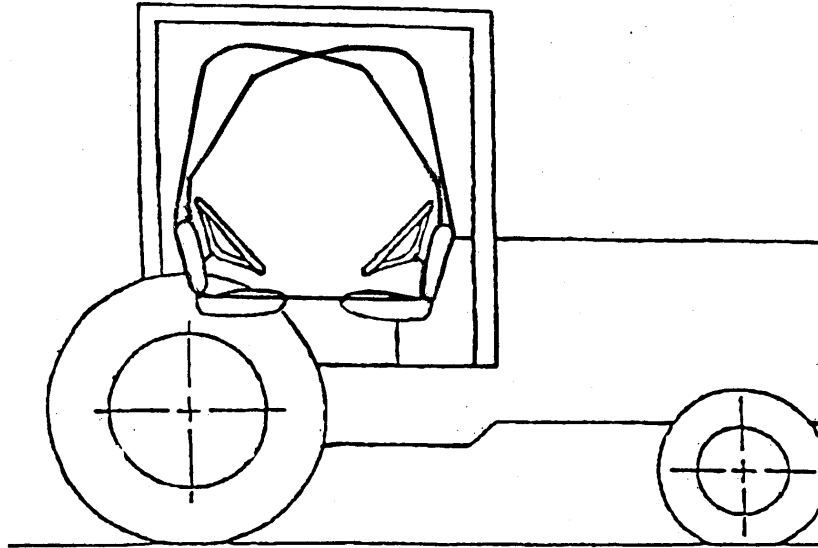

Figure 3.14(a): Protective cab

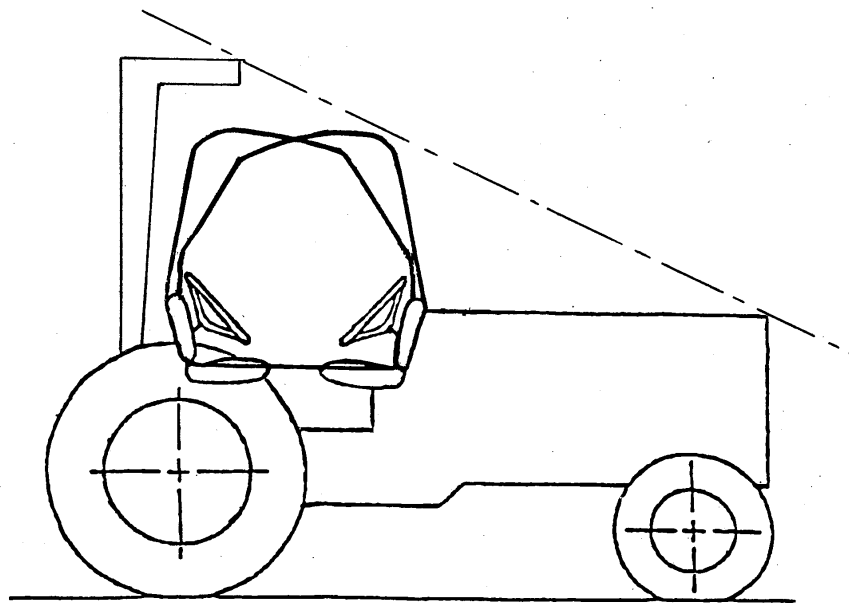
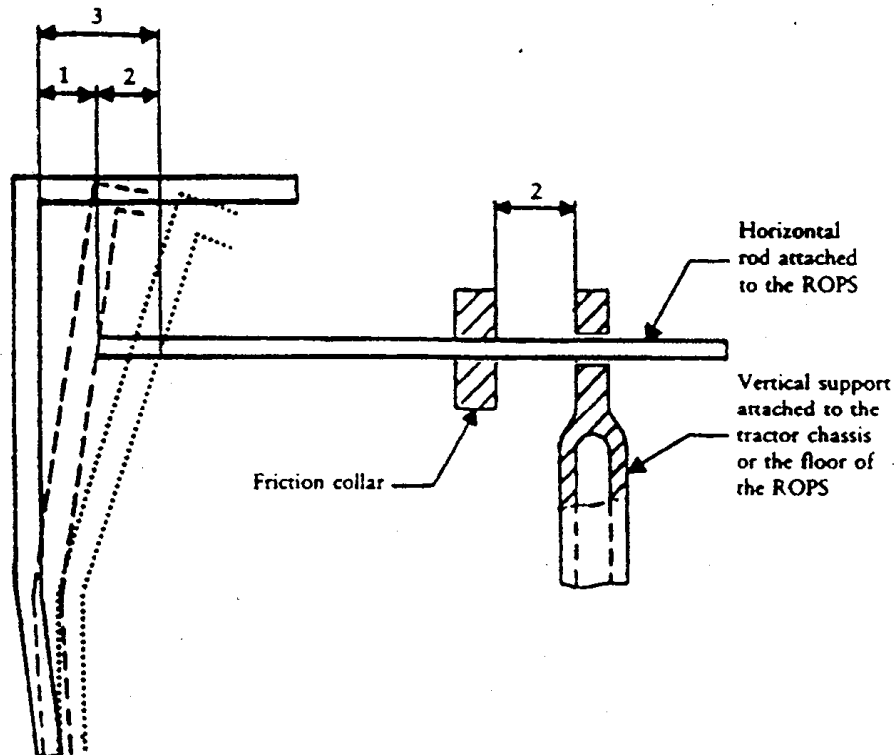

Figure 3.14(b): Rear roll bar frame

**Clearance zone for tractor with reversible seat and steering wheel,
protective cab and rear roll bar frame**



1. Permanent deflection
2. Elastic deflection
3. Total deflection (permanent plus elastic)

Figure 3.15

Example of apparatus for measuring elastic deflection

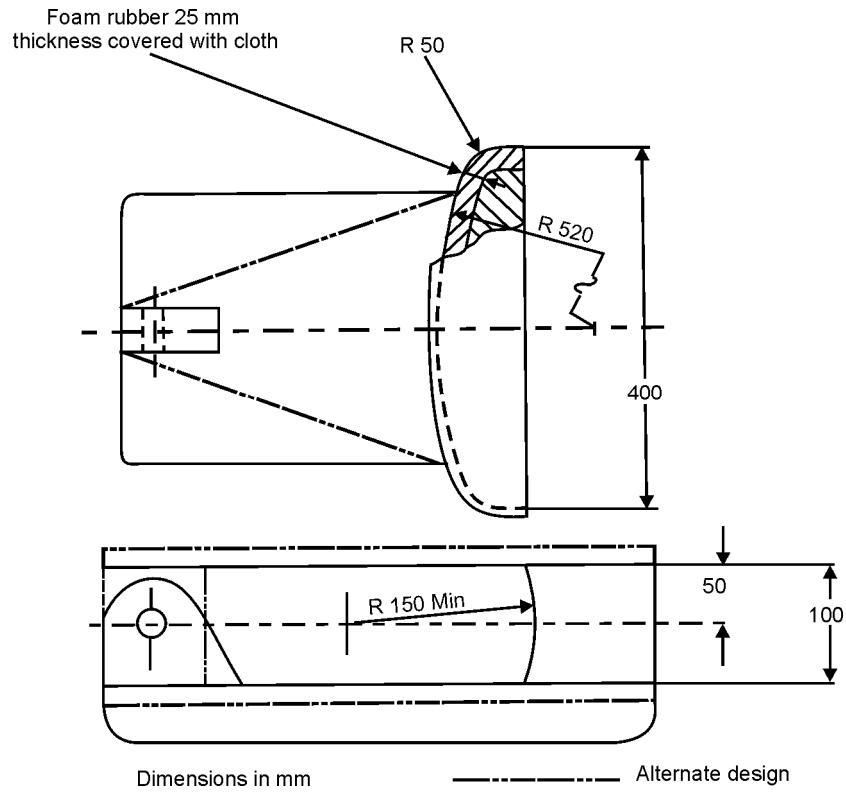

Figure 3.16

The load application device

(The dimensions not shown are optional to satisfy the test facility and do not influence the test results)

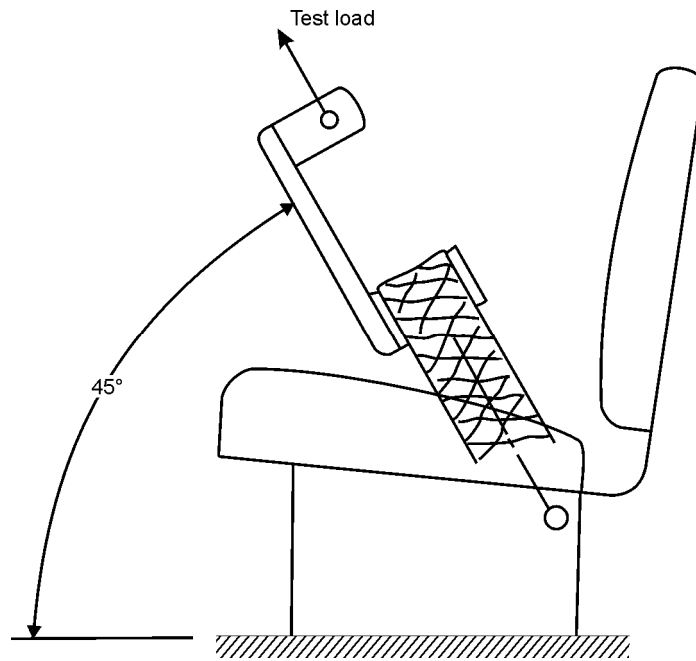

Figure 3.17

Load application in the upward and forward direction

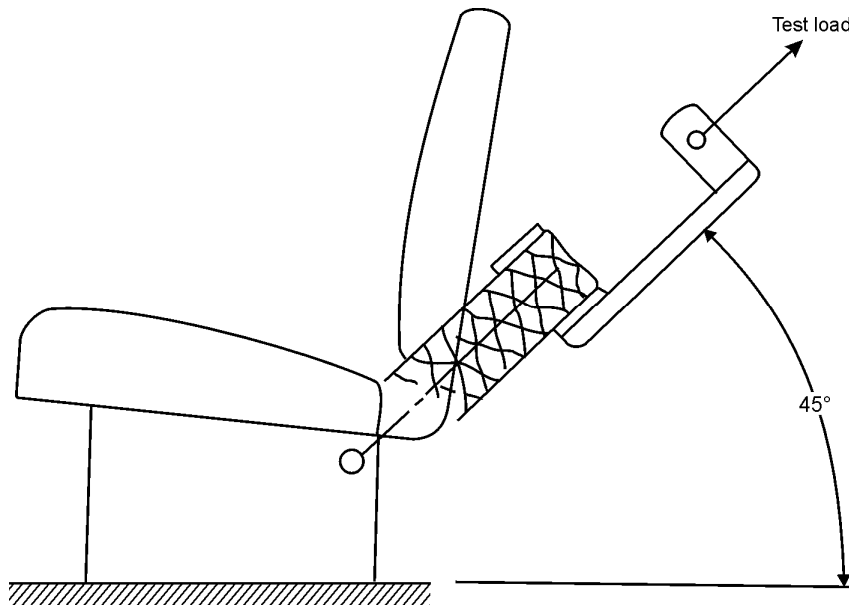

Figure 3.18

Load application in the upward and rearward direction

SPECIMEN TEST REPORT

Note: Units shown below, which appear in ISO 1000:1992; Amd1:1998, shall be stated and followed by national units in parentheses, if necessary.

- Protective structure manufacturer's name and address:
- Submitted for test by:
- Make of the protective structure:
- Model of the protective structure:
- Type of the protective structure: Cab, Frame, Rear rollbar, Cab with integrated frame, etc.
- Date, location of test and Code version:

1. SPECIFICATION OF TEST TRACTOR

1.1 Identification of tractor to which the protective structure is fitted for the test

- 1.1.1 - Make of the tractor: (*)
 - Model (trade name):
 - Type: 2 WD or 4 WD; rubber or steel tracks (if applicable);
 articulated 4 WD or articulated 4 WD with twin (dual) wheels (if applicable)

(*) possibly different from tractor manufacturer's name

1.1.2 Numbers

- 1st Serial No. or prototype:
- Serial No.:

1.1.3 Other specifications (if applicable)

- Model denomination(s) for other countries:
- Transmission type or gears x ranges:
- Speed version: 30 or 40 km/h:
- Manufacturer identification or Technical type number:

1.2 Mass of unballasted tractor with protective structure fitted and without driver

Front	kg
Rear	kg
Total	kg

- Mass used for calculating impact energies and crushing forces: kg

1.3 Wheelbase and moment of inertia

- Wheelbase of test tractor: mm
- Moment of inertia used for calculating impact energy at the rear: kg.m²

1.4 Minimum track and tyre sizes

	Minimum track	Tyre sizes
Front	mm	
Rear	mm	

1.5 Tractor seat

- Tractor with a reversible driver’s position (reversible seat and steering wheel): Yes / No
- Make/ type/ model of driver’s seat:
- Make/ type/ model of optional seat(s) and position(s) of the seat reference point (SRP) :
 - (description of seat 1 and SRP position)
 - (description of seat 2 and SRP position)
 - (description of seat __ and SRP position)
- Anchorage: Type
- Seat mounting on the tractor: Type
- Other seat components: Type
- Seat operating position in the test: Description

Masses used for calculating the loads

Seat	Make/Model/Type
Components	Mass (kg)
Driver seat:	
Seat belt assembly:	
Other seat components:	
Total:	

2. SPECIFICATION OF PROTECTIVE STRUCTURE

2.1 Photographs from side and rear showing mounting details including mudguards

2.2 General arrangement drawing of the side and the rear of the structure including position of the seat reference points (SRP) and details of mountings and position of the front part of the tractor capable of supporting the tractor when overturned (if necessary).

2.3 Brief description of the protective structure comprising:

- type of construction;
- details of mountings;
- details of cladding and padding;
- details of the part of the front of the tractor capable of supporting the tractor when overturned (if necessary)

- means of access and escape;
- additional frame: Yes / No

2.4 Tilttable / not tilttable structure

2.5 Dimensions

Dimensions should be measured with seatpan and backrest loaded and adjusted according to Definition 1.4 of the Code.

When the tractor is fitted with different optional seats or has a reversible driver's position (reversible seat and steering wheel), the dimensions in relation to the seat reference points shall be measured in each case (SRP 1, SRP 2, etc.).

2.5.1	Height of roof members above the seat reference point:	mm
2.5.2	Height of roof members above the tractor footplate:	mm
2.5.3	Interior width of the protective structure 900 mm above the seat reference point	:mm
2.5.4	Interior width of the protective structure vertically above the seat reference point at the level of centre of the steering wheel:	mm
2.5.5	Distance from the centre of the steering wheel to the right-hand side of the protective structure:	mm
2.5.6	Distance from the centre of the steering wheel to the left-hand side of the protective structure:	mm
2.5.7	Minimum distance from the steering wheel rim to the protective structure:	mm
2.5.8	Width of the doorways <ul style="list-style-type: none"> • at the top: • in the middle: • at the bottom: 	mm mm mm
2.5.9	Height of the doorways <ul style="list-style-type: none"> • above foot platforms: • above highest mounting steps: • above lowest mounting steps: 	mm mm mm
2.5.10	Overall height of the tractor with the protective structure fitted:	mm
2.5.11	Overall width of the protective structure (if mudguards are included, this is to stated):	mm
2.5.12	Horizontal distance from the seat reference point to the rear of the protective structure at a height of 900 mm above the seat reference point:	mm

2.5.13 Position (with reference to the rear axle) of the front part of tractor capable of supporting the tractor when overturned:

horizontal distance: mm
vertical distance: mm

2.6 Details of materials used in the construction of the protective structure and specifications of steels used

Steel specifications shall be in conformity with ISO 630:1995; Amd1:2003.

2.6.1 Main frame: (parts - material - sizes)

- Is steel rimmed, semi-killed or killed:
- steel standard and reference:

2.6.2 Mountings: (parts - material - sizes)

- Is steel rimmed, semi-killed or killed:
- steel standard and reference:

2.6.3 Assembly and mounting bolts: (parts - sizes)

2.6.4 Roof : (parts - material - sizes)

2.6.5 Cladding: (parts - material - sizes)

2.6.6 Glass: (type - grade - sizes)

2.6.7 Front part of the tractor capable of supporting the tractor when overturned (parts – material - sizes) (if necessary)

2.7. Details of tractor manufacturer's reinforcements on original parts

3. TEST RESULTS

3.1 Impact and crushing tests

3.1.1 Condition of tests

- Impact tests were made:

- to the rear left / right
- to the front right / left
- to the side right / left

- Mass used for calculating impact energies and crushing forces: kg

- Wheelbase used for calculating impact energy at the rear: mm/kgm²

- Moment of inertia used for calculating impact energy at the rear: kgm²

- Energies and forces applied:

- rear: kJ
- front: kJ
- side: kJ
- crushing force: kN

3.1.2 Permanent deflections measured after the tests

3.1.2.1 Permanent deflections of the extremities of the protective structure measured after the series of tests:

- Back (forwards / backwards):
 - left-hand: mm
 - right-hand: mm
- Front (forwards / backwards):
 - left-hand: mm
 - right-hand: mm
- Sideways (to the left / to the right):
 - front: mm
 - rear: mm
- Top (downwards / upwards):
 - rear: left-hand: mm
 - right-hand: mm
 - front: left-hand: mm
 - right-hand: mm

3.1.2.2 Difference between total instantaneous deflection and residual deflection during sideways impact test (elastic deflection): mm

Statement:

The acceptance conditions of these tests relative to the protection of the clearance zone are fulfilled. The structure is a roll-over protective structure in accordance with the Code.

3.2 Cold weather performance (resistance to brittle fracture)

Method used to identify resistance to brittle fracture at reduced temperature:

- .
- .
- .

Steel specifications shall be in conformity with ISO 630:1995; Amd1:2003.

Steel specification: (reference and relevant standard)

3.3 Seatbelt anchorage performance

3.3.1 Loading in the forward and upward direction

Driver seat	make/model/type	
GRAVITY FORCE ($F_g = \text{seat mass} \times 9.81$) N	REQUIRED FORCE ($4450N + 4F_g$) N	APPLIED FORCE N

3.3.2. Loading in the rearward and upward direction

Driver seat	make/model/type	
GRAVITY FORCE ($F_g = \text{seat mass} \times 9.81$) N	REQUIRED FORCE ($2225 + 2F_g$) N	APPLIED FORCE N

3.3.3 Curves, drawings and photos

A copy of the force/deflection curves derived during the tests shall be included.

Drawings and/or photos of the seat mounting and anchorages have to be added.

Statement:

During the test, no structural failure or release of seat, seat adjuster mechanism or other locking service occurred. The seat and safety belt anchorage tested fulfil the requirement of the OECD procedure.

3.4 Tractor(s) to which the protective structure is fitted

OECD Approval Number :										
Make	Model	Type	Other specifications	Mass			Tiltable	Wheel-Base	Minimum track	
				Front	Rear	Total			Front	Rear
		<i>2/4 WD, etc</i>	<i>where applicable</i>	kg	kg	kg	Yes/ No	mm	mm	

SPECIMEN TECHNICAL EXTENSION REPORT

Note: Units shown below, which appear in ISO 1000:1992; Amd1:1998, shall be stated and followed by national units in parentheses, if necessary.

- Protective structure manufacturer's name and address:
- Submitted for test by:

- Make of the protective structure:
- Model of the protective structure:
- Type of the protective structure: Cab, Frame, Rear rollbar, Cab with integrated frame, etc.

- Date, location of extension and Code version:

Reference of the original test :

Approval number and date of the original test report :

Statement giving the reasons of the extension and explaining the procedure chosen :

Depending on the case some of the following paragraphs may be omitted if their content is identical to the one of the original test report. It is only necessary to highlight the differences between the tractor and protective structure described in the original test report and the one for which the extension has been required.

1. SPECIFICATION OF TEST TRACTOR

1.1 Identification of tractor to which the protective structure is fitted for the test

- 1.1.1 - Make of the tractor: (*)
 - Model (trade name):
 - Type: 2 WD or 4 WD; rubber or steel tracks (if applicable);
 articulated 4 WD or articulated 4 WD with twin (dual) wheels (if applicable)

(*) possibly different from tractor manufacturer's name

- 1.1.2 Numbers
 - 1st Serial No. or prototype:
 - Serial No.:

- 1.1.3 Other specifications (if applicable)
 - Model denomination(s) for other countries:
 - Transmission type or gears x ranges:
 - Speed version: 30 or 40 km/h:
 - Manufacturer identification or Technical type number:

1.2 Mass of unballasted tractor with protective structure fitted and without driver

Front	kg
Rear	kg
Total	kg

- Mass used for calculating impact energies and crushing forces: kg

1.3 Wheelbase and moment of inertia

- Wheelbase of test tractor: mm
- Moment of inertia used for calculating impact energy at the rear: kgm²

1.4 Minimum track and tyre sizes

	Minimum track	Tyre sizes
Front	mm	
Rear	mm	

1.5 Tractor seat

- Tractor with a reversible driver’s position (reversible seat and steering wheel): Yes / No
- Make/ type/ model of driver’s seat:
- Make/ type/ model of optional seat(s) and position(s) of the seat reference point (SRP) :
 - (description of seat 1 and SRP position)
 - (description of seat 2 and SRP position)
 - (description of seat ___ and SRP position)
- Anchorage: Type
- Seat mounting on the tractor: Type
- Other seat components: Type
- Seat operating position in the test: Description

Masses used for calculating the loads

Seat	Make/Model/Type
Components	Mass (kg)
Driver seat:	
Seat belt assembly:	
Other seat components:	
Total:	

2. SPECIFICATION OF PROTECTIVE STRUCTURE

2.1 Photographs from side and rear showing mounting details including mudguards

2.2 General arrangement drawing of the side and the rear of the structure including position of the seat reference points (SRP) and details of mountings and position of the front part of the tractor capable of supporting the tractor when overturned (if necessary).

2.3 Brief description of the protective structure comprising:

- type of construction;
- details of mountings;
- details of cladding and padding;
- details of the front part of the tractor capable of supporting the tractor when overturned (if necessary)
- means of access and escape;
- additional frame: Yes / No

2.4 Tilttable / not tilttable structure**2.5 Dimensions**

Dimensions should be measured with seatpan and backrest loaded and adjusted according to Definition 1.4 of the Code.

When the tractor is fitted with different optional seats or has a reversible driver's position (reversible seat and steering wheel), the dimensions in relation to the seat reference points shall be measured in each case (SRP 1, SRP 2, etc.).

2.5.1	Height of roof members above the seat reference point:	mm
2.5.2	Height of roof members above the tractor footplate:	mm
2.5.3	Interior width of the protective structure 900 mm above the seat reference point:	mm
2.5.4	Interior width of the protective structure vertically above the seat reference point at the level of centre of the steering wheel:	mm
2.5.5	Distance from the centre of the steering wheel to the right-hand side of the protective structure:	mm
2.5.6	Distance from the centre of the steering wheel to the left-hand side of the protective structure:	mm
2.5.7	Minimum distance from the steering wheel rim to the protective structure:	mm
2.5.8	Width of the doorways <ul style="list-style-type: none"> • at the top: • in the middle: • at the bottom: 	mm mm mm
2.5.9	Height of the doorways <ul style="list-style-type: none"> • above foot platforms: • above highest mounting steps: • above lowest mounting steps: 	mm mm mm
2.5.10	Overall height of the tractor with the protective structure fitted:	mm
2.5.11	Overall width of the protective structure (if mudguards are included, this is to stated):	mm

- 2.5.12 Horizontal distance from the seat reference point to the rear of the protective structure at a height of 900 mm above the seat reference point: mm
- 2.5.13 Position (with reference to the rear axle) of the front part of tractor capable of supporting the tractor when overturned:
 horizontal distance: mm
 vertical distance: mm

2.6 Details of materials used in the construction of the protective structure and specifications of steels used

Steel specifications shall be in conformity with ISO 630:1995; Amd1:2003.

- 2.6.1 Main frame: (parts - material - sizes)
 • Is steel rimmed, semi-killed or killed:
 • steel standard and reference:
- 2.6.2 Mountings: (parts - material - sizes)
 • Is steel rimmed, semi-killed or killed:
 • steel standard and reference:
- 2.6.3 Assembly and mounting bolts: (parts - sizes)
- 2.6.4 Roof : (parts - material - sizes)
- 2.6.5 Cladding: (parts - material - sizes)
- 2.6.6 Glass: (type - grade - sizes)
- 2.6.7 Front part of the tractor capable of supporting the tractor when overturned (if necessary) (parts – material- sizes)

2.7. Details of tractor manufacturer's reinforcements on original parts

3. TEST RESULTS (in case of validation test)

3.1 Impact and crushing tests

- 3.1.1 Condition of tests
- Impact tests were made:
 - to the rear left / right
 - to the front right / left
 - to the side right / left
 - Mass used for calculating impact energies and crushing forces: kg
 - Wheelbase used for calculating impact energy at the rear: mm/kg.m²
 - Moment of inertia used for calculating impact energy at the rear: kg.m²
 - Energies and forces applied:
 - rear: kJ
 - front: kJ
 - side: kJ

	Permanent deflection measured after impact test		
	original test mm	validation test mm	relative deviation %
Rear impact test			
Front impact test			
Side impact test			

3.2 Cold weather performance (resistance to brittle fracture)

Method used to identify resistance to brittle fracture at reduced temperature:

- .
- .
- .

Steel specifications shall be in conformity with ISO 630:1995; Amd1:2003.

Steel specification: (reference and relevant standard)

3.3 Seatbelt anchorage performance

3.3.1 Loading in the forward and upward direction

Driver seat	make/model/type	
GRAVITY FORCE ($F_g = \text{seat mass} \times 9.81$) N	REQUIRED FORCE ($4450N + 4F_g$) N	APPLIED FORCE N

3.3.2. Loading in the rearward and upward direction

Driver seat	make/model/type	
GRAVITY FORCE ($F_g = \text{seat mass} \times 9.81$) N	REQUIRED FORCE ($2225 + 2F_g$) N	APPLIED FORCE N

3.3.3 Curves, drawings and photos

A copy of the force/deflection curves derived during the tests shall be included.

Drawings and/or photos of the seat mounting and anchorages have to be added.

Statement:

During the test, no structural failure or release of seat, seat adjuster mechanism or other locking service occurred. The seat and safety belt anchorage tested fulfil the requirement of the OECD procedure.

3.4 Tractor(s) to which the protective structure is fitted

OECD Approval Number :										
Make	Mode 1	Type	Other specifi- cations	Mass			Tiltable	Wheel- Base	Minimum track	
				Front	Rear	Total			Front	Rear
		<i>2/4 WD, etc</i>	<i>where applicable</i>	kg	kg	kg	Yes/ No	mm	mm	

SPECIMEN ADMINISTRATIVE EXTENSION REPORT

Note: Units shown below, which appear in ISO 1000:1992; Amd1:1998, shall be stated and followed by national units in parentheses, if necessary.

Date, location of extension and Code version:

Reference of the original test :

Approval number and date of the original test report :

Statement giving the reasons of the extension and explaining the procedure chosen :

1. Specification of the protective structure

- Type of the protective structure: Cab, Frame, Rear rollbar, Cab with integrated frame, etc.
- Manufacturer's name and address:
- Submitted for extension by:
- Make :
- Model :
- Type :
- Serial number from which the modification applies

2. Denomination of the tractor(s) to which the protective structure is fitted

OECD Approval Number :										
Make	Model	Type	Other specifications	Mass			Tiltable	Wheel-Base	Minimum track	
				Front	Rear	Total			Front	Rear
		<i>2/4 WD, etc</i>	<i>where applicable</i>	kg	kg	kg	Yes/ No	mm	mm	

3. Details of modifications

Since the original test report the following modifications have been made:

4. Statement:

The modifications do not affect the results of the original test.

The original test report therefore applies.