

# OECD GUIDELINES FOR THE TESTING OF CHEMICALS

## PROPOSAL FOR A NEW GUIDELINE

### Sediment-Water Chironomid Life-Cycle Toxicity Test Using Spiked Water or Spiked Sediment

#### INTRODUCTION

1. This test guideline is designed to assess the effects of life-long exposure of chemicals to the freshwater dipteran *Chironomus* sp, fully covering the first generation and the early part of the second generation. It is an extension of the existing OECD test guideline 219 or 218 using a spiked-water exposure scenario (1) or a spiked sediment scenario (15), respectively. It takes into account existing toxicity test protocols for *Chironomus riparius* and *Chironomus dilutus* (previously named *C. tentans* (2)) that have been developed in Europe and North America (3-9) and subsequently ring-tested (1, 7, 10, 11, 12). Other well documented chironomid species may also be used, e.g. *Chironomus yoshimatsui* (13, 14).
2. Both water and sediment exposure scenarios are described in this guideline. The selection of an appropriate exposure scenario depends on the intended application of the test. The water exposure scenario, spiking of the water column, is intended to simulate a pesticide spray drift event and covers the initial peak concentration in surface waters. Water spiking is also useful for other types of exposure (including chemical spills), but not for accumulation processes within the sediment lasting longer than the test period. In that case, and also when run-off is the main entry route of pesticides into water bodies, a spiked sediment design may be more appropriate. If other exposure scenarios are of interest, the test design may be readily adapted. For example, if the distribution of the test compound between the water phase and the sediment layer is not of interest, and adsorption to the sediment has to be minimized the use of a surrogate artificial sediment (e.g. quartzsand) may be considered.
3. Substances that require testing of sediment-dwelling organisms usually persist in sediment over long periods. Sediment-dwelling organisms may be exposed via a number of routes. The relative importance of each exposure route, and the time taken for each to contribute to the overall toxic effect, is dependent on the physical-chemical properties of the substance. For strongly adsorbing substances (e.g. with  $\log K_{ow} > 5$ ) or for substances covalently binding to sediment, ingestion of contaminated food may be a significant exposure route. In order not to underestimate the toxicity of highly lipophilic substances, the use of food added to the sediment before application of the test substance may be considered (26). Therefore, it is possible to include all routes of exposure and all lifestages. The complete exposure duration is ca. 44 days for *C. riparius* and *C. yoshimatsui*, and 65 - 95 days for *C. dilutus*.
4. Measured endpoints are the total number of adults emerged (for both 1<sup>st</sup> and 2<sup>nd</sup> generations), development rate (for both 1<sup>st</sup> and 2<sup>nd</sup> generations), sex ratio of fully emerged and alive adults (for both 1<sup>st</sup> and 2<sup>nd</sup> generations), number of egg ropes per female (1<sup>st</sup> generation only) and fertility of the egg ropes (1<sup>st</sup> generation only).
5. Formulated sediment is strongly recommended. Formulated sediment has several advantages over natural sediments:

- experimental variability is reduced because it forms a reproducible "standardised matrix" and the need to source uncontaminated clean sediment is eliminated;
- tests can be initiated at any time without encountering seasonal variability in the test sediment and there is no need to pre-treat the sediment to remove indigenous fauna;
- reduced cost compared to field collection of sufficient quantities required for routine testing;
- formulated sediment allows for comparisons of toxicity across studies and ranking substances accordingly (3).

6. Definitions used are given in Annex 1.

### **PRINCIPLE OF THE TEST**

7. First instar chironomid larvae are exposed to a concentration range of the test substance in a sediment-water system. The test starts by placing first instar larvae (1<sup>st</sup> generation) into test beakers containing spiked sediment or alternately the test substance is spiked into the water after addition of the larvae. Chironomid emergence, time to emergence and sex ratio of the fully emerged and alive midges are assessed. Emerged adults are transferred to breeding cages, to facilitate swarming, mating and oviposition. The number of egg ropes produced and their fertility are assessed. From these egg ropes, first instar larvae of the second (F1) generation are obtained. These larvae are placed into freshly prepared test beakers (spiking procedure as for the first generation) to determine the viability of the second generation through an assessment of their emergence, time to emergence and the sex ratio of the fully emerged and alive midges. All data are analysed either by a regression model to estimate the concentration that would cause X% reduction in the relevant endpoint, or by using hypothesis testing to determine a No Observed Effect Concentration (NOEC). The latter requires a comparison of treatment responses with the appropriate control responses using statistical tests.

It should be noted that in the spiked water scenario, in case of fast degrading substances, the later life stages of each generation (e.g. pupal phase) might be exposed to a considerably lower concentration level in the overlying water than the 1<sup>st</sup> instar larvae. If this is a concern, and a comparable exposure level for each life stage is required, the following amendments of the test method might be considered:

- parallel runs with spiking at different life stages or
- repeated spiking of the test system during both test phases, whereby the spiking intervals should be adjusted to the fate characteristics of the test substance.

Such amendments are only feasible in the spiked water scenario, but not in the sediment spiked scenario.

### **INFORMATION ON THE TEST SUBSTANCE**

8. The water solubility of the test substance, its vapour pressure and log  $K_{ow}$ , measured or calculated partitioning into sediment and stability in water and sediment should be known. A reliable analytical method for the quantification of the test substance in overlying water, pore water and sediment with known and reported accuracy and limit of detection should be available. Useful information includes the structural formula and purity of the test substance. Chemical fate of the test substance (e.g. dissipation, abiotic and biotic degradation, etc.) is also useful. Further guidance for testing substances with physical-chemical properties that make them difficult to perform the test is provided in (16).

### **REFERENCE SUBSTANCES**

9. Reference substances may be tested periodically as a means of assuring that the sensitivity of the laboratory population has not changed. As with daphnids it would be sufficient to perform a 48-h acute test (following 17). However, until a validated acute guideline is available a chronic test according to OECD Test Guideline 219 may be considered. Examples of reference toxicants used successfully in ring-tests and validation studies are: lindane, trifluralin, pentachlorophenol, cadmium chloride and potassium chloride. (1, 3, 6, 7, 18).

### **VALIDITY OF THE TEST**

10. For the test to be valid the following conditions apply:
- emergence in the controls must be at least 70% at the end of the exposure period for both generations (1, 7);
  - for *C. riparius* and *C. yoshimatsui* emergence to adults from control vessels should occur between 12 and 23 days after their insertion into the vessels; for *C. dilutus*, a period of 20 to 65 days is acceptable;
  - sex ratio of fully emerged and alive adults (as female or male fraction) in the controls of both generations should be at least 0.4, but not exceed 0.6;
  - for each breeding cage the number of egg ropes in the controls of the first generation should be at least 0.6 per female added to the breeding cage;
  - the fraction of fertile egg ropes in the controls of the first generation should be at least 0.6;
  - at the end of the exposure period for both generations, pH and the dissolved oxygen concentration should be measured in each vessel. The oxygen concentration should be at least 60% of the air saturation value (ASV), and the pH of overlying water should be in the range of 6-9 in all test vessels;
  - the water temperature should not differ by more than  $\pm 1.0^{\circ}\text{C}$ .

### **DESCRIPTION OF THE METHOD**

#### **Test vessels and breeding cages**

11. The larvae are exposed in 600 mL glass beakers measuring ca. 8.5 cm in diameter. Other vessels are suitable, but they should guarantee a suitable depth of overlying water and sediment. The sediment surface should be sufficient to provide 2 to 3 cm<sup>2</sup> per larvae. The ratio of the depth of the sediment layer to the depth of the overlying water should be 1:4.

Breeding cages (minimum. 30 cm in all three dimensions) with a gauze (mesh size ca. 1 mm) on the top and one side of the cage as a minimum should be used. In each cage a 2 L crystallising dish, containing test water and sediment, is placed for oviposition. Also for the crystallising dish, the ratio of the depth of the sediment layer to the depth of the overlying water should be around 1:4.

After egg ropes are collected from the crystallising dish they are placed into a 12-well microtiter plate (one rope per well containing ca. 2.5 mL water from the spiked crystallising dish).

With the exception of the microtiter plates, all test vessels and other apparatus that will come into contact with the test system should be made entirely of glass or other chemically inert material (e.g. Teflon).

#### **Selection of species**

12. The species to be used in the test is preferably *Chironomus riparius*. *C. yoshimatsui* may also be used. *C. dilutus* is also suitable but more difficult to handle and requires a longer test period. Details of culturing methods are given in Annex 2 for *C. riparius*. Information on culture conditions are also

available for *C. dilutus* (5) and *C. yoshimatsui* (14). Identification of the species must be confirmed before testing but is not required prior to every test if the organisms come from an in-house culture.

### **Sediment**

13. Formulated sediment (also called reconstituted, artificial or synthetic sediment) should preferably be used. However, if natural sediment is used, it should be characterised (at least pH, organic carbon content, determination of other parameters such as C/N ratio and granulometry are also recommended) and should be free from any contamination and other organisms that may compete with, or consume chironomid larvae. It is also recommended, before testing, that natural sediment be conditioned for seven days under test conditions.

The following formulated sediment, as described in (1), is recommended (1, 20, 21):

- (a) 4-5% (dry weight) peat: as close to pH 5.5 to 6.0 as possible; it is important to use peat in powder form, finely ground (particle size  $\leq 1$  mm) and only air dried.
- (b) 20% (dry weight) kaolin clay (kaolinite content preferably above 30%).
- (c) 75-76% (dry weight) quartz sand (fine sand should predominate with more than 50 per cent of the particles between 50 and 200  $\mu\text{m}$ ).
- (d) Deionised water is added to obtain moisture of the final mixture in the range of 30–50%.
- (e) Calcium carbonate of chemically pure quality ( $\text{CaCO}_3$ ) is added adjust the pH of the final mixture of the sediment to  $7.0 \pm 0.5$ .
- (f) Organic carbon content of the final mixture should be 2% ( $\pm 0.5\%$ ) and is to be adjusted by the use of appropriate amounts of peat and sand, according to (a) and (c).

14. The source of peat, kaolin clay and sand should be known. The sediment components should be checked for the absence of chemical contamination (e.g. heavy metals, organochlorine compounds, organophosphorous compounds). An example for the preparation of the formulated sediment is described in Annex 3. Mixing of dry constituents is also acceptable if it is demonstrated that after addition of overlying water a separation of sediment constituents (e.g. floating of peat particles) does not occur, and that the peat or the sediment is sufficiently conditioned.

### **Water**

15. Any water which conforms to the chemical characteristics of acceptable dilution water as listed in Annexes 2 and 4 is suitable as test water. Any suitable water, natural water (surface or ground water), reconstituted water (see Annex 2) or dechlorinated tap water are acceptable as culturing water and test water, if chironomids will survive in it for the duration of the culturing and testing without showing signs of stress. At the start of the test, the pH of the test water should be between 6 and 9 and the total hardness not higher than 400 mg/L as  $\text{CaCO}_3$ . However, if there is an interaction suspected between hardness ions and the test substance, lower hardness water should be used (and thus, Elendt Medium M4 must not be used in this situation). The same type of water should be used throughout the entire study. The water quality characteristics listed in Annex 4 should be measured at least twice a year or when it is suspected that these characteristics may have changed significantly.

### **Stock solutions - Spiked water**

16a. Test concentrations are calculated on the basis of water column concentrations, i.e. the water overlying the sediment. Test solutions of the chosen concentrations are usually prepared by dilution of a stock solution. Stock solutions should preferably be prepared by dissolving the test substance in test water.

The use of solvents or dispersants may be required in some cases in order to produce a suitably concentrated stock solution. Examples of suitable solvents are acetone, ethanol, methanol, ethylene glycol monoethyl ether, ethylene glycol dimethyl ether, dimethylformamide and triethylene glycol. Dispersants which may be used are Cremophor RH40, Tween 80, methylcellulose 0.01% and HCO-40. The solubilising agent concentration in the final test medium should be minimal (i.e.  $\leq 0.1$  mL/L) and should be the same in all treatments. When a solubilising agent is used, it must have no significant effects on survival as revealed by a solvent control. However, every effort should be made to avoid the use of such materials.

### **Stock solutions - Spiked sediment**

16b. Spiked sediments of the chosen concentration are usually prepared by addition of a solution of the test substance directly to the sediment. A stock solution of the test substance dissolved in deionised water is mixed with the formulated sediment by rolling mill, feed mixer or hand mixing. If poorly soluble in water, the test substance can be dissolved in as small a volume as possible of a suitable organic solvent (e.g. hexane, acetone or chloroform). This solution is then mixed with 10 g of fine quartz sand for one test vessel. The solvent is allowed to evaporate and it has to be totally removed from sand; the sand is then mixed with the suitable amount of sediment per test beaker. Only agents which volatilise readily can be used to solubilise, disperse or emulsify the test substance. It should be born in mind that the sand provided by the test substance and sand mixture, has to be taken into account when preparing the sediment (i.e. the sediment should thus be prepared with less sand). Care should be taken to ensure that the test substance added to sediment is thoroughly and evenly distributed within the sediment. If necessary, subsamples can be analysed to determine degree of homogeneity.

### **TEST DESIGN**

17. The test design relates to the selection of the number and spacing of the test concentrations, the number of vessels at each concentration, the number of larvae per vessel, the number of crystallising dishes and breeding cages. Designs for  $EC_x$ , NOEC and a limit test are described below.

#### **Design for analysis by regression**

18. The effect concentration ( $EC_x$ ) and the concentration range over which the effect of the test substance is of interest, should be spanned by the test, such that the endpoint is not extrapolated outside the bounds of the data generated. Extrapolation much below the lowest or above the highest concentration should be avoided. A preliminary range-finding test according to OECD TG 218 or 219 may be helpful for selecting a suitable range of test concentrations.

19. For an  $EC_x$  approach, at least five concentrations and eight replicates for each concentration are required. For each concentration two breeding cages should be used (A and B). The eight replicates are divided into two groups of four replicates to serve each breeding cage. This merger of replicates is necessary due to the number of midges needed in the cage for sound reproduction assessments. However, the F1 generation has eight replicates again, which are initiated from the exposed populations in the breeding cages. The factor between concentrations should not be greater than two (an exception could be made in cases when the dose response curve has a shallow slope). The number of replicates at each treatment can be reduced to six (three for each breeding case) if the number of test concentrations with different responses is increased. Increasing the number of replicates or reducing the size of the test concentration intervals tends to lead to narrower confidence intervals around the  $EC_x$ .

#### **Design for estimation of a NOEC**

20. For a NOEC approach, five test concentrations with at least eight replicates (4 for each breeding cage, A and B) should be used and the factor between concentrations should not be greater than two. The number of replicates should be sufficient to ensure adequate statistical power to detect a 20% difference from the control at the 5% level of significance ( $\alpha = 0.05$ ). For the development rate, fecundity and fertility an analysis of variance (ANOVA) is usually appropriate, followed by Dunnett's test or Williams' test (22-25). For the emergence ratio and sex ratio the Cochran-Armitage, Fisher's exact (with Bonferroni correction), or Mantel-Haentzel tests may be appropriate.

### **Limit test**

21. A limit test may be performed (one test concentration and control(s)) if no effects are observed in the optional preliminary range-finding test up to a maximum concentration. The purpose of the limit test is to indicate that any toxic effects of the test substance are found at levels greater than the limit concentration tested. For water, 100 mg/L and for sediment 1000 mg/kg (dry weight) are suggested. Usually, at least eight replicates for both the treatment and control are necessary. Adequate statistical power to detect a 20% difference from the control at the 5% level of significance ( $\alpha = 0.05$ ) should be demonstrated. With metric responses (e.g. development rate), the t-test is a suitable statistical method if data meet the requirements of this test (normality, homogeneous variances). An unequal-variance t-test or a non-parametric test, such as the Wilcoxon-Mann-Whitney test may be used, if these requirements are not fulfilled. With the emergence ratio, Fisher's exact test is appropriate.

## **PROCEDURE**

### **Conditions of exposure**

#### **Preparation of the water-sediment system (water spiking)**

22a. Appropriate amounts of formulated sediment (see paragraphs 13-14 and Annex 3) are added to each test vessel and crystallising dish to form a layer of at least 1.5 cm (for the crystallising dish it may be somewhat lower) but maximally 3 cm. Water (see paragraph 15) is added so that the ratio of the depth of the sediment layer and the depth of the water does not exceed 1:4. After preparation of the test vessels the sediment-water system should be left under gentle aeration for approximately seven days prior to addition of the first instar larvae of the 1<sup>st</sup> or 2<sup>nd</sup> generation (see paragraph 14 and Annex 3). The sediment-water system of the crystallising dishes is not aerated during the test, since they do not need to support larval survival. To avoid separation of sediment ingredients and re-suspension of fine material during addition of test water in the water column, the sediment can be covered with a plastic disc while water is poured onto it. The disc is removed immediately afterwards. Other devices may also be appropriate.

#### **Preparation of the water-sediment system (spiked sediment)**

22b. The spiking procedure described in OECD Guideline 207 "Earthworm, acute toxicity test" is recommended for application of the test substance (19), see also paragraph 16b. The spiked sediments are placed in the vessels and crystallising dish and overlying water is added to produce a sediment-water volume ratio of 1:4. The depth of the sediment layer should be in the range of 1.5 to 3 cm (it may be somewhat lower for the crystallising dish). To avoid separation of sediment ingredients and re-suspension of fine material during addition of test water in the water column, the sediment can be covered with a plastic disc while water is poured onto it, and the disc removed immediately afterwards. Other devices may also be appropriate. Once the spiked sediment with overlying water has been prepared, it is desirable to allow partitioning of the test substance from the aqueous phase to the sediment (4, 5, 7, 18). This should preferably be done under the conditions of temperature and aeration used in the test. Appropriate

equilibration time is sediment and chemical specific, and can be in the order of hours to days and in rare cases up to five weeks. As this would leave time for degradation of many chemicals, equilibrium is not awaited but a equilibration period of 48 hours is recommended. At the end of this further equilibration period, the concentration of the test substance should be measured in the overlying water, the pore water and the sediment, at least at the highest concentration and a lower one (see paragraph 38). These analytical determinations of the test substance allow for calculation of mass balance and expression of results based on measured concentrations.

23. Test vessels should be covered (e.g. by glass plates). If necessary, during the study the water levels may be topped up to the original volume in order to compensate for evaporation. This should be performed using distilled or deionised water to prevent any build-up of salts. Crystallising dishes in the breeding cages are not covered and do not need to be adjusted to compensate for water loss during the test period, since the egg ropes are only in contact with the water for about one day and the dishes are only used during a short phase of the test.

#### **Addition of test organisms**

24. Four to five days before adding the first instar larvae for the 1<sup>st</sup> generation, egg masses should be taken from the culture and placed in small vessels in culture medium. Aged medium from the stock culture or freshly prepared medium may be used. In any case, a small amount of food, e.g. green algae and/or a few droplets of filtrate from a finely ground suspension of flaked fish food, should be added to the culture medium (see Annex 2). Only freshly laid egg masses should be used. Normally, the larvae begin to hatch a couple of days after the eggs are laid (2 to 3 days for *C. riparius* at 20°C and 1 to 4 days for *C. dilutus* at 23°C and *C. yoshimatui* at 25°C) and larval growth occurs in four instars, each of 4-8 days duration. First instar larvae (2-3 or 1-4 days post hatching) should be used in the test. The instar stage of larvae can potentially be checked using head capsule width (7).

25. Twenty first instar larvae for the 1<sup>st</sup> generation are allocated randomly to each test vessel containing the sediment-water system, using a blunt pipette. Aeration of the water is stopped whilst adding larvae to test vessels and should remain so for 24 hours following addition of larvae (see paragraph 32). According to the test design used (see paragraphs 19 and 20), the number of larvae used per concentration is at least 120 (6 replicates per concentration) for the EC<sub>X</sub> approach and 160 for the NOEC approach (8 replicates per concentration). In the spiked sediment design, exposure starts with the addition of the larvae.

#### **Spiking the overlying water**

26. Twenty-four hours after adding the first instar larvae for the 1<sup>st</sup> generation, the test substance is spiked into the overlying water column, and slight aeration is again supplied (for possible amendments of the test design, see paragraph 7). Small volumes of the test substance stock solutions are applied below the surface of the water using a pipette. The overlying water should then be mixed with care not to disturb the sediment. In the spiked water design, exposure starts with the spiking of the water (i.e. one day after addition of the larvae).

#### **Collecting emerged adults**

27. Emerged midges of the 1<sup>st</sup> generation are collected preferably twice a day (see point 36) from the test vessels using an aspirator, exhaustor or similar device (see Annex 5). Special care should be taken not to damage the adults. The collected midges from four test vessels within one treatment are released into a breeding cage to which they had been previously assigned. At the day of first (male) emergence, crystallising dishes are spiked by pipetting a small volume of the test substance stock solution below the water surface (spiked water design). The overlying water should then be mixed with care not to disturb the

sediment. The concentration of test substance in the crystallising dish is nominally the same as in the treatment vessels which are assigned to that specific breeding cage. For the spiked sediment design, the crystallising dishes are prepared at around day 11 after the start of the exposure (i.e. addition of the first generation larvae) so that they can equilibrate for about 48 hours before the first egg ropes are produced.

28. Egg ropes are collected from the crystallising dish in the breeding cage using tweezers or a blunt pipette. Each egg rope is placed into a vessel containing culture medium from the crystallising dish it was collected from (e.g. a well of a 12-well micro-plate together with ca. 2.5 mL of medium). Egg ropes are kept for observation for at least six days after they have been produced so that they can be classified as fertile or infertile.

For starting the 2<sup>nd</sup> generation, at least three but preferably six fertile egg ropes are selected from each breeding cage and together with some food allowed to hatch. These egg ropes should have been produced at the peak of oviposition, which normally occurs around test day 19 in the controls. Ideally, the 2<sup>nd</sup> generation of all treatments is initiated on the same day, but due to substance related effects on larval development, this may not always be possible. In such a case, the higher concentrations may be initiated later than the lower treatments, including the (solvent) control.

29a. In the spiked water design, the sediment-water system for the 2<sup>nd</sup> generation is prepared by spiking the test substance into the overlying water column ca. 1 hour before adding the first instar larvae to the test vessels. Small volumes of the test substance solutions are applied below the surface of the water using a pipette. The overlying water should then be mixed with care not to disturb the sediment. After spiking, slight aeration is supplied.

29b. In the spiked sediment design, the exposure vessels containing the sediment-water system for the 2<sup>nd</sup> generation are prepared in the same way as for the first generation.

30. Twenty first instar larvae (2-3 days post hatching) of the 2<sup>nd</sup> generation are allocated randomly to each test vessel containing the spiked sediment-water system, using a blunt pipette. Aeration of the water has to be stopped while adding the first instar larvae to the test vessels and remain so for another 24 hours after addition of the larvae. According to the test design used (see paragraphs 19 and 20), the number of larvae used per concentration is at least 120 (6 replicates per concentration) for the EC<sub>x</sub> approach and 160 for the NOEC approach (8 replicates per concentration).

## Food

31. It is necessary to feed the larvae in the test vessels, preferably daily or at least three times per week. Fish-food (a suspension in water or finely ground food, e.g. Tetra-Min or Tetra-Phyll; see details in Annex 2) of 0.25 - 0.5 mg (0.35 - 0.5 mg for *C. yoshimatsui*) per larvae per day is an adequate amount of food for young larvae during the first 10 days of their development. Slightly more food may be necessary for older larvae: 0.5 – 1.0 mg per larvae per day should be sufficient for the rest of the test. The food ration should be reduced in all treatments and control if fungal growth is seen or if mortality is observed in controls. If fungal development cannot be stopped the test should be repeated. When testing strongly adsorbing substances (e.g. with  $\log K_{ow} > 5$ ), or substances covalently binding to the sediment, the amount of food necessary to ensure survival and natural growth of the larvae may be added to the formulated sediment before the stabilisation period. For this, plant material must be used instead of fish food, e.g. addition of 0.5% (dry weight) finely ground leaves of e.g. stinging nettle (*Urtica dioica*), mulberry (*Morus alba*), white clover (*Trifolium repens*), spinach (*Spinacia oleracea*) or of other plant material (*Cerophyl* or alpha-cellulose) may be used (26).

Adult midges in the breeding cage need no feeding normally, but when deemed necessary a cotton wool pad soaked in a saturated sucrose solution may serve as a food source for emerged adults.

### Incubation conditions

32. Gentle aeration of the overlying water in the test vessels is supplied 24 hours after addition of the first instar larvae of both generations and is continued throughout the test (care should be taken that the dissolved oxygen concentration does not fall below 60% of ASV). Aeration is provided through a glass Pasteur pipette of which the outlet is fixed 2-3 cm above the sediment layer giving a few bubbles/sec. When testing volatile chemicals, consideration should be given not to aerate the sediment-water system.

33. The test with *C. riparius* is conducted at a constant temperature of 20°C ( $\pm 2^\circ\text{C}$ ). For *C. dilutus* and *C. yoshimatsui*, recommended temperatures are 23°C and 25°C ( $\pm 2^\circ\text{C}$ ), respectively. A 16 hours photoperiod is used and the light intensity should be 500 to 1000 lux. For the breeding cages an additional one hour dawn and dusk phase may be included.

### Exposure duration

34. Spiked water design: The exposure period of the 1<sup>st</sup> generation starts when the test item is spiked into the overlying water of the test vessels (which is one day after insertion of the larvae – for possible amendments of the exposure design, see paragraph 7). Exposure of the 2<sup>nd</sup> larval generation starts immediately, since they are inserted into a sediment-water system that has been already spiked. The maximum exposure duration for the 1<sup>st</sup> generation is 27 days and for the 2<sup>nd</sup> generation 28 days (the 1<sup>st</sup> generation larvae spend one day in the vessels without exposure) for *C. riparius* and *C. yoshimatsui*. Considering the overlap, the complete test duration is approximately 44 days. For *C. dilutus*, maximum exposure durations are 64 and 65 days, for the 1<sup>st</sup> and 2<sup>nd</sup> generation, respectively. The total duration is approximately 100 days.

Spiked sediment design: exposure starts with the addition of the larvae and is maximum 28 days for both generations for *C. riparius* and *C. yoshimatsui*.

### Observations

#### Emergence

35. Development time and the total number of fully emerged and alive male and female midges are determined for both generations. Males are easily identified by their plumose antennae and thin body posture.

36. Test vessels of both generations should be observed at least three times per week to make visual assessment of any abnormal behaviour of the larvae (e.g. leaving sediment, unusual swimming), compared to the control. During the period of emergence, which starts about 12 days after insertion of the larvae for *C. riparius* and *C. yoshimatsui* (after 20 days for *C. dilutus*), emerged midges are counted and sexed preferably twice a day (early morning and late afternoon). After identification, the midges of the 1<sup>st</sup> generation are carefully removed from the vessels and transferred to a breeding cage. Midges of the 2<sup>nd</sup> generation are removed and killed after identification. Any egg ropes deposited in the test vessels of the first generation should be collected and transferred with ca. 2.5 mL native water to 12-well microplates. The number of dead larvae and visible pupae that have failed to emerge should also be recorded. Guidance on monitoring of emergence is provided in Annex 5.

#### Reproduction

37. Effects on reproduction are assessed via the number of egg ropes produced by the first generation of midges and the fertility of these egg ropes. Once per day the egg ropes are collected from the crystallising dish that is placed in each breeding container. The egg ropes should be collected and

transferred with ca. 2.5 mL native water to a 12-wells microplate (one egg rope in each well). The following characteristics are documented for each egg rope: day of production, size (normal or small), structure (normal = spiralled or abnormal, e.g. unspiralled) and fertility (fertile or infertile). Over the course of six days after it was produced the fertility of an egg rope is assessed. An egg rope is considered fertile when at least one third of the eggs hatch. The total number of females added to the breeding cage is used to calculate the number of egg ropes per female and the number of fertile egg ropes per female.

### **Analytical measurements**

#### **Concentration of the test substance**

38. As a minimum, samples of the overlying water, pore water and the sediment must be analysed at the start of exposure (in case of water spiking preferably one hour after application) and at the end of the test, at the highest concentration and a lower one. This applies to vessels from both generations. From the crystallising dishes in the breeding cage only the overlying water is analysed, since this is what the egg ropes come into contact with (for the spiked sediment design an analytical confirmation of the sediment concentration may be considered). Further measurements of sediment, pore water or overlying water during the test may be conducted if deemed necessary. These determinations of test substance concentration inform on the behaviour/partitioning of the test chemical in the water-sediment system. Sampling of sediment and pore water at the start and during the test (see paragraph 39) requires additional test vessels to perform analytical determinations. Measurements in sediment in the spiked water design might not be necessary if the partitioning of the test substance between water and sediment has been clearly determined in a water/sediment study under comparable conditions (e.g. sediment to water ratio, type of application, organic carbon content of sediment), or if measured concentrations in the overlying water are shown to remain within 80 to 120% of the nominal or measured initial concentrations..

39. When intermediate measurements are made (e.g. at day 7 and/or 14) and if the analysis needs large samples which cannot be taken from test vessels without influencing the test system, analytical determinations should be performed on samples from additional test vessels treated in the same way (including the presence of test organisms) but not used for biological observations.

40. Centrifugation at e.g. 10,000 g at 4°C for 30 min is the recommended procedure to isolate interstitial (= pore) water. However, if the test substance is demonstrated not to adsorb to filters, filtration may also be acceptable. In some cases it might not be possible to analyse concentrations in the pore water as the sample volume may be too small.

#### **Physical-chemical parameters**

41. pH, dissolved oxygen in the test water and temperature of the water in the test vessels and crystallising dishes should be measured in an appropriate manner (see paragraph 10). Hardness and ammonia should be measured in the controls and in one test vessel and crystallising dish at the highest concentration at the start and the end of the test.

### **DATA AND REPORTING**

#### **Treatment of results**

42. The purpose of this life-cycle test is to determine the effect of the test substance on the reproduction and, for two generations, the development rate and the total number of fully emerged and

alive male and female midges. If there are no statistically significant differences between the sensitivities of sexes, male and female results may be pooled for statistical analysis.

43. Effect concentrations expressed as concentrations in the overlaying water (for spiked water) or in the sediment (for spiked sediment), are calculated preferably based on measured concentrations at the beginning of the exposure (see paragraph 38). Therefore, for spiked water, initial measured concentrations in overlying water of the vessels for both generations and those of the crystallising dishes are averaged for each treatment. For spiked sediment, initial measured concentrations in sediment of the vessels for both generations (and optionally those of the crystallising dishes) are averaged for each treatment.

44. To compute a point estimate for the  $EC_{50}$  or any other  $EC_x$ , the per-vessel and per-breeding cage statistics may be used as true replicates. In calculating a confidence interval for any  $EC_x$  the variability among vessels should be taken into account, or it should be shown that this variability is so small that it can be ignored. When the model is fitted by Least Squares, a transformation should be applied to the per-vessel statistics in order to improve the homogeneity of variance. However,  $EC_x$  values should be calculated after the response is transformed back to the original value.

45. When the statistical analysis aims at determining the NOEC by hypothesis testing, the variability among vessels needs to be taken into account, e.g. by a nested ANOVA. Alternatively, more robust tests (27) can be appropriate in situations where there are violations of the usual ANOVA assumptions.

### Emergence ratio

46. Emergence ratios are quantal data, and can be analyzed by the Cochran-Armitage test applied in a step-down manner where a monotonic dose-response is expected and these data are consistent with this expectation. If not, a Fisher's exact or Mantel-Haentz test with Bonferroni-Holm adjusted p-values can be used. If there is evidence of greater variability between replicates within the same concentration than a binomial distribution would indicate (often referenced to as "extra-binomial" variation), then a robust Cochran-Armitage or Fisher exact test such as proposed in (27), should be used.

The sum of live midges emerged per vessel,  $n_e$ , is determined and divided by the number of larvae introduced,  $n_a$ :

$$ER = \frac{n_e}{n_a}$$

where:

$ER$  = emergence ratio

$n_e$  = number of live midges emerged per vessel

$n_a$  = number of larvae introduced per vessel (normally 20)

47. An alternative approach that is most appropriate for large sample sizes, when there is extra binomial variance, is to treat the emergence ratio as a continuous response and use procedures such as Williams' test when a monotonic dose-response is expected and is consistent with these  $ER$  data. Dunnett's test would be appropriate where monotonicity does not hold. A large sample size is defined here as the number emerged and the number not emerging both exceeding five, on a per replicate (vessel) basis.

48. To apply ANOVA methods, values of  $ER$  should first be transformed by the arcsin-sqrt transformation or Tukey-Freeman transformation to obtain an approximate normal distribution and to

equalise variances. The Cochran-Armitage, Fisher's exact (Bonferroni), or Mantel-Haentzel tests can be applied when using the absolute frequencies. The arcsin-sqrt transformation is applied by taking the inverse sine ( $\sin^{-1}$ ) of the square root of  $ER$ .

49. For emergence ratios,  $EC_x$ -values are calculated using regression analysis (e.g. probit, logit or Weibull models (28)). If regression analysis fails (e.g. when there are less than two partial responses), other non-parametric methods such as moving average or simple interpolation can be used.

### Development rate

50. Mean development time represents the mean time span between the introduction of larvae (day 0 of the test) and the emergence of the experimental cohort of midges (for calculation of the true development time, the age of larvae at the time of introduction should be considered). The development rate (unit: 1/day) is the reciprocal of the development time and represents that portion of larval development which takes place per day. Development rate is preferred for the evaluation of these sediment toxicity studies as its variance is lower, and it is more homogeneous and closer to a normal distribution compared to the development time. Hence, more powerful parametric test procedures may be used with development rate unlike development time. For development rate as a continuous response,  $EC_x$ -values can be estimated by regression analysis (e.g. 29, 30). A NOEC for the mean development rate can be determined via ANOVA, followed by Williams' or Dunnett's test.

51. For statistical testing, the number of midges observed on inspection day  $x$  are assumed to be emerged at the mean of the time interval between day  $x$  and day  $x-1$  ( $l$  = length of the inspection interval, usually 1 day). The mean development rate per vessel ( $\bar{x}$ ) is calculated according to:

$$\bar{x} = \sum_{i=1}^m \frac{f_i x_i}{n_e}$$

where:

- $\bar{x}$  : mean development rate per vessel
- $i$  : index of inspection interval
- $m$  : maximum number of inspection intervals
- $f_i$  : number of midges emerged in the inspection interval  $i$
- $n_e$  : total number of midges emerged at the end of experiment ( $= \sum f_i$ )
- $x_i$  : development rate of the midges emerged in interval  $i$

$$x_i = \frac{1}{\left(\text{day}_i - \frac{l_i}{2}\right)}$$

where:

- $\text{day}_i$  : inspection day (days since introduction of the larvae)
- $l_i$  : length of inspection interval  $i$  (days, usually 1 day)

### Sex ratio

52. Sex ratios are quantal data and should therefore be evaluated by means of a Fisher's exact test or other appropriate methods. The natural sex ratio of *C. riparius* is one, i.e. males and females are equally abundant. For both generations (P and F1) the sex ratio data should be treated identically. Since the maximum number of midges per vessel (i.e. 20) is too low for a meaningful statistical analysis, the total number of fully emerged and alive midges for each gender is summed over all vessels of one treatment. These untransformed data are tested against the solvent control or pooled control data in a 2 x 2 contingency table.

### **Reproduction**

53. Reproduction, as fecundity, is calculated as the number of egg ropes per female. More specific, the total number of egg ropes produced in a breeding cage is divided by the total number of adult females added to that cage. A NOEC for fecundity can be determined via ANOVA, followed by Williams' or Dunnett's test.

54. Fertility of the egg ropes is used to quantify the number of fertile egg ropes per female. The total number of fertile egg ropes produced in a breeding cage is divided by the total number of adult females added to that cage. A NOEC for fertility can be determined via ANOVA, followed by Williams' or Dunnett's test.

**Test report**

55. The test report should provide the following information:

Test substance:

- physical nature and physical-chemical properties (water solubility, vapour pressure,  $\log K_{ow}$ , partition coefficient in soil (or in sediment if available), stability in water and sediment etc.);
- chemical identification data (common name, chemical name, structural formula, CAS number, etc.) including purity and analytical method for the quantification of the test substance.

Test species:

- test organisms used: species, scientific name, source of organisms and breeding conditions;
- information on how the egg masses and larvae were handled;
- information on handling of the emerged adults of the 1<sup>st</sup> generation with the help of an exhaustor etc (see Annex 5)
- age of the test organisms at the time of insertion into the test vessels of the 1<sup>st</sup> and 2<sup>nd</sup> generation.

Test conditions:

- sediment used, i.e. natural or formulated (artificial) sediment;
- natural sediment: location and description of sediment sampling site, including, if possible, contamination history; sediment characteristics: pH, organic carbon content, C/N ratio and granulometry (if appropriate).
- formulated sediment: preparation, ingredients and characteristics (organic carbon content, pH, moisture, etc. measured at the start of the test);
- preparation of the test water (if reconstituted water is used) and characteristics (oxygen concentration, pH, conductivity, hardness, etc. measured at the start of the test);
- depth of sediment and overlaying water for the test vessels and crystallising dishes;
- volume of overlying and pore water; weight of wet sediment with and without pore water for the test vessels and the crystallising dishes;
- test vessels (material and size);
- crystallising dishes (material and size);
- breeding cages (material and size)
- method of preparation of stock solutions and test concentrations for the test vessels and crystallising dishes;
- application of the test item into the test vessels and crystallising dishes: test concentrations, number of replicates and solvents if needed;
- incubation conditions for the test vessels: temperature, light cycle and intensity, aeration (frequency and intensity);
- incubation conditions for the breeding cages and the crystallising dishes: temperature, light cycle and intensity;
- incubation conditions for the micro plates: temperature, light cycle and intensity;
- detailed information on feeding including type of food, preparation, amount and feeding regime.

## Results:

- nominal test concentrations, measured test concentrations and the results of all analyses to determine the concentration of the test substance in the test vessels and crystallising dishes;
- water quality within the test vessels and crystallising dishes, i.e. pH, temperature, dissolved oxygen, hardness and ammonia;
- replacement of evaporated test water for the test vessels, if any;
- number of emerged male and female midges per vessel and per day for the 1<sup>st</sup> and 2<sup>nd</sup> generation;
- sex ratio of fully emerged and alive midges per treatment for the 1<sup>st</sup> and 2<sup>nd</sup> generation
- number of larvae which failed to emerge as midges per vessel for the 1<sup>st</sup> and 2<sup>nd</sup> generation;
- percentage/fraction of emergence per replicate and test concentration (male and female midges pooled) for the 1<sup>st</sup> and 2<sup>nd</sup> generation;
- mean development rate of fully emerged and alive midges per replicate and treatment rate (male and female midges pooled) for the 1<sup>st</sup> and 2<sup>nd</sup> generation;
- number of egg ropes laid inside the crystallising dishes per breeding cage and day;
- visual estimation of the egg ropes per micro plate well and day (size, shape and fertility);
- fecundity – total number of egg ropes per total number of females added to the breeding cage;
- fertility – total number of fertile egg ropes per total number of females added to the breeding cage;
- estimates of toxic endpoints e.g. EC<sub>x</sub> (and associated confidence intervals), NOEC and the statistical methods used for its determination;
- discussion of the results, including any influence on the outcome of the test resulting from deviations from this guideline.

**LITERATURE**

- (1) OECD (2004) Sediment-water chironomid toxicity test using spiked water. TG 219.
- (2) Shobanov, N.A., Kiknadze, I.I. and M.G. Butler (1999) Palearctic and Nearctic *Chironomus* (*Camptochironomus*) *tentans* Fabricius are different species (Diptera: Chironomidae). *Entomologica Scandinavica*, 30: 311–322.
- (3) Fleming, R. *et al.* (1994) Sediment Toxicity Tests for Poorly Water-Soluble Substances. Final Report to the European Commission. Report No: EC 3738. August 1994. WRc, UK.
- (4) SETAC (1993) Guidance Document on Sediment toxicity Tests and Bioassays for Freshwater and Marine Environments. From the WOSTA Workshop held in the Netherlands.
- (5) ASTM International/E1706-00 (2002) Test Method for Measuring the Toxicity of Sediment-Associated Contaminants with Freshwater Invertebrates. pp 1125-1241. In: ASTM International 2002 Annual Book of Standards. Volume 11.05. Biological Effects and Environmental Fate; Biotechnology; Pesticides. ASTM International, West Conshohocken, PA.
- (6) Environment Canada (1997) Test for Growth and Survival in Sediment using Larvae of Freshwater Midges (*Chironomus tentans* or *Chironomus riparius*). Biological Test Method. Report SPE 1/RM/32. December 1997.
- (7) US-EPA (2000) Methods for Measuring the Toxicity and Bioaccumulation of Sediment-associated Contaminants with Freshwater Invertebrates. Second edition. EPA 600/R-99/064. March 2000. Revision to the first edition dated June 1994.
- (8) US-EPA/OPPTS 850.1735 (1996) Whole Sediment Acute Toxicity Invertebrates.
- (9) US-EPA/OPPTS 850.1790 (1996) Chironomid Sediment toxicity Test.
- (10) Milani, D., Day, K.E., McLeay, D.J. and R.S. Kirby (1996) Recent intra- and inter-laboratory studies related to the development and standardisation of Environment Canada's biological test methods for measuring sediment toxicity using freshwater amphipods (*Hyalella azteca*) and midge larvae (*Chironomus riparius*). Technical Report. Environment Canada. National Water Research Institute. Burlington, Ontario, Canada.
- (11) Norberg-King, T.J., Sibley, P.K., Burton, G.A., Ingersoll, C.G., Kemble, N.E., Ireland, S., Mount, D.R. and C.D. Rowland (2006) Interlaboratory evaluation of *Hyalella azteca* and *Chironomus tentans* short-term and long-term sediment toxicity tests. *Environ. Toxicol. Chem.*, 25: 2662-2674.
- (12) Taenzler, V., Bruns, E., Dorgerloh, M., Pfeifle, V. and L. Weltje (2007) Chironomids: suitable test organisms for risk assessment investigations on the potential endocrine-disrupting properties of pesticides. *Ecotoxicology*, 16: 221-230.
- (13) Sugaya, Y. (1997) Intra-specific variations of the susceptibility of insecticides in *Chironomus yoshimatsui*. *Jp. J. Sanit. Zool.*, 48: 345-350.
- (14) Kawai, K. (1986) Fundamental studies on chironomid allergy. I. Culture methods of some Japanese chironomids (Chironomidae, Diptera). *Jp. J. Sanit. Zool.*, 37: 47-57.

- (15) OECD (2004) Sediment-water chironomid toxicity test using spiked sediment. TG 218.
- (16) OECD (2000) Guidance Document on Aquatic Toxicity Testing of Difficult Substances and Mixtures. OECD Environment, Health and Safety Publications, Series on Testing and Assessment No. 23.
- (17) Weltje, L., Rufli, H., Heimbach, F., Wheeler, J., Vervliet-Scheebaum, M. and M. Hamer (In press) The chironomid acute toxicity test: development of a new test system. *Integr. Environ. Assess. Management*.
- (18) Environment Canada. (1995) Guidance Document on Measurement of Toxicity Test Precision Using Control Sediments Spiked with a Reference Toxicant. Report EPS 1/RM/30. September 1995.
- (19) OECD Test Guideline 207 (1984) Earthworm, Acute Toxicity Test.
- (20) Suedel, B.C. and J.H. Rodgers (1994) Development of formulated reference sediments for freshwater and estuarine sediment testing. *Environ. Toxicol. Chem.*, 13: 1163-1175.
- (21) Naylor, C. and C. Rodrigues (1995) Development of a test method for *Chironomus riparius* using a formulated sediment. *Chemosphere*, 31: 3291-3303.
- (22) Dunnett, C.W. (1964) A multiple comparisons procedure for comparing several treatments with a control. *J. Amer. Statist. Assoc.*, 50: 1096-1121.
- (23) Dunnett, C.W. (1964) New tables for multiple comparisons with a control. *Biometrics*, 20: 482-491.
- (24) Williams, D.A. (1971) A test for differences between treatment means when several dose levels are compared with a zero dose control. *Biometrics*, 27: 103-117.
- (25) Williams, D.A. (1972) The comparison of several dose levels with a zero dose control. *Biometrics*, 28: 510-531.
- (26) Jungmann, D., Bandow, C., Gildemeister, T., Nagel, R., Preuss, T.G., Ratte, H.T., Shinn, C., Weltje, L. and H.M. Maes (2009) Chronic toxicity of fenoxycarb to the midge *Chironomus riparius* after exposure in sediments of different composition. *J Soils Sediments*, 9: 94-102.
- (27) Rao, J.N.K. and A.J. Scott (1992) A simple method for the analysis of clustered binary data. *Biometrics*, 48: 577-585.
- (28) Christensen, E.R. (1984) Dose-response functions in aquatic toxicity testing and the Weibull model. *Water Res.*, 18: 213-221.
- (29) Bruce, R.D. and D.J. Versteeg (1992) A statistical procedure for modelling continuous toxicity data. *Environ. Toxicol. Chem.*, 11: 1485-1494.
- (30) Slob, W. (2002) Dose-response modelling of continuous endpoints. *Toxicol. Sci.*, 66: 298-312.

**XXX**

**OECD/OCDE**

**ANNEX 1**

**DEFINITIONS**

For the purpose of this guideline the following definitions are used:

Formulated sediment or reconstituted, artificial or synthetic sediment, is a mixture of materials used to mimic the physical components of a natural sediment.

Overlying water is the water placed over sediment in the test vessel.

Interstitial water or pore water is the water occupying space between sediment and soil particles.

Spiked water is the test water to which test substance has been added.

ANNEX 2RECOMMENDATIONS FOR CULTURE OF *CHIRONOMUS RIPARIUS*

1. *Chironomus* larvae may be reared in crystallising dishes or larger containers. Fine quartz sand is spread in a thin layer of about 5 to 10 mm deep over the bottom of the container. Kieselgur (e.g. Merck, Art 8117) has also been shown to be a suitable substrate (a thinner layer of up to a very few mm is sufficient). Suitable water is then added to a depth of several cm. Water levels should be topped up as necessary to replace evaporative loss, and prevent desiccation. Water can be replaced if necessary. Gentle aeration should be provided. The larval rearing vessels should be held in a suitable cage which will prevent escape of the emerging adults. The cage should be sufficiently large to allow swarming of emerged adults, otherwise copulation may not occur (minimum is ca. 30 x 30 x 30 cm).

2. Cages should be held at room temperature or in a constant environment room at  $20 \pm 2^\circ\text{C}$  with a photo period of 16 hour light (intensity ca. 1000 lux), 8 hours dark. It has been reported that air humidity of less than 60% RH can impede reproduction.

Dilution water

3. Any suitable natural or synthetic water may be used. Well water, dechlorinated tap water and artificial media (e.g. Elendt "M4" or "M7" medium, see below) are commonly used. The water has to be aerated before use. If necessary, the culture water may be renewed by pouring or siphoning the used water from culture vessels carefully without destroying the tubes of larvae.

Feeding larvae

4. *Chironomus* larvae should be fed with a fish flake food (Tetra Min<sup>®</sup>, Tetra Phyll<sup>®</sup> or other similar brand of proprietary fish food), at approximately 250 mg per vessel per day. This can be given as a dry ground powder or as a suspension in water: 1.0 g of flake food is added to 20 ml of dilution water and blended to give a homogenous mix. This preparation may be fed at a rate of about 5 ml per vessel per day. (shake before use.) Older larvae may receive more.

5. Feeding is adjusted according to the water quality. If the culture medium becomes 'cloudy', the feeding should be reduced. Food additions must be carefully monitored. Too little food will cause emigration of the larvae towards the water column, and too much food will cause increased microbial activity and reduced oxygen concentrations. Both conditions can result in reduced growth rates.

6. Some green algae (e.g. *Scenedesmus subspicatus*, *Chlorella vulgaris*) cells may also be added when new culture vessels are set up.

Feeding emerged adults

7. Some experimenters have suggested that a cotton wool pad soaked in a saturated sucrose solution may serve as a food for emerged adults.

**Emergence**

8. At  $20 \pm 2$  °C adults will begin to emerge from the larval rearing vessels after approximately 13 - 15 days. Males are easily distinguished by having plumose antennae and thin body.

**Egg masses**

9. Once adults are present within the breeding cage, all larval rearing vessels should be checked three times weekly for deposition of the gelatinous egg masses. If present, the egg masses should be carefully removed. They should be transferred to a small dish containing a sample of the breeding water. Egg masses are used to start a new culture vessel (e.g. 2 - 4 egg masses / vessel) or are used for toxicity tests.

10. First instar larvae should hatch after 2 - 3 days.

**Set-up of new culture vessels**

11. Once cultures are established it should be possible to set up a fresh larval culture vessel weekly or less frequently depending on testing requirements, removing the older vessels after adult midges have emerged. Using this system a regular supply of adults will be produced with a minimum of management.

**Preparation of test solutions "M4" and "M7"**

12. Elendt (1990) has described the "M4" medium. The "M7" medium is prepared as the "M4" medium except for the substances indicated in Table 1, for which concentrations are four times lower in "M7" than in "M4". The test solution should not be prepared according to Elendt and Bias (1990) for the concentrations of  $\text{NaSiO}_3 \cdot 5\text{H}_2\text{O}$ ,  $\text{NaNO}_3$ ,  $\text{KH}_2\text{PO}_4$  and  $\text{K}_2\text{HPO}_4$  given for the preparation of the stock solutions are not adequate.

**Preparation of the "M7"-medium**

13. Each stock solution (I) is prepared individually and a combined stock solution (II) is prepared from these stock solutions (I) (see Table 1). Fifty ml from the combined stock Solution (II) and the amounts of each macro nutrient stock solution which are given in Table 2 are made up to 1 litre of deionised water to prepare the "M7" medium. A vitamin stock solution is prepared by adding three vitamins to deionised water as indicated in Table 3, and 0.1 ml of the combined vitamin stock solution are added to the final "M7" medium shortly before use. The vitamin stock solution is stored frozen in small aliquots. The medium is aerated and stabilised.

**Table 1: Stock solutions of trace elements for medium M4 and M7**

Stock solutions (I)	Amount (mg) made up to 1 litre of deionised water	To prepare the combined stock solution (II): mix the following amounts (ml) of stock solutions (I) and make up to 1 litre of deionised water		Final concentrations in test solutions (mg/l)	
		M4	M7	M4	M7
H <sub>3</sub> BO <sub>3</sub> <sup>(1)</sup>	57190	1.0	0.25	2.86	0.715
MnCl <sub>2</sub> · 4H <sub>2</sub> O <sup>(1)</sup>	7210	1.0	0.25	0.361	0.090
LiCl <sup>(1)</sup>	6120	1.0	0.25	0.306	0.077
RbCl <sup>(1)</sup>	1420	1.0	0.25	0.071	0.018
SrCl <sub>2</sub> · 6H <sub>2</sub> O <sup>(1)</sup>	3040	1.0	0.25	0.152	0.038
NaBr <sup>(1)</sup>	320	1.0	0.25	0.016	0.004
Na <sub>2</sub> MoO <sub>4</sub> · 2H <sub>2</sub> O <sup>(1)</sup>	1260	1.0	0.25	0.063	0.016
CuCl <sub>2</sub> · 2H <sub>2</sub> O <sup>(1)</sup>	335	1.0	0.25	0.017	0.004
ZnCl <sub>2</sub>	260	1.0	1.0	0.013	0.013
CaCl <sub>2</sub> · 6H <sub>2</sub> O	200	1.0	1.0	0.010	0.010
KI	65	1.0	1.0	0.0033	0.0033
Na <sub>2</sub> SeO <sub>3</sub>	43.8	1.0	1.0	0.0022	0.0022
NH <sub>4</sub> VO <sub>3</sub>	11.5	1.0	1.0	0.00058	0.00058
Na <sub>2</sub> EDTA · 2H <sub>2</sub> O <sup>(1)(2)</sup>	5000	20.0	5.0	2.5	0.625
FeSO <sub>4</sub> · 7H <sub>2</sub> O <sup>(1)(2)</sup>	1991	20.0	5.0	1.0	0.249

(1) These substances differ in M4 and M7, as indicated above.

(2) These solutions are prepared individually, then poured together and autoclaved immediately.

**Table 2: Macro nutrient stock solutions for medium M4 and M7**

	Amount made up to 1 litre of deionised water (mg)	Amount of macro nutrient stock solutions added to prepare medium M4 and M7 (ml/l)	Final concentrations in test solutions M4 and M7 (mg/l)
CaCl <sub>2</sub> · 2H <sub>2</sub> O	293800	1.0	293.8
MgSO <sub>4</sub> · 7H <sub>2</sub> O	246600	0.5	123.3
KCl	58000	0.1	5.8
NaHCO <sub>3</sub>	64800	1.0	64.8
NaSiO <sub>3</sub> · 9H <sub>2</sub> O	50000	0.2	10.0
NaNO <sub>3</sub>	2740	0.1	0.274
KH <sub>2</sub> PO <sub>4</sub>	1430	0.1	0.143
K <sub>2</sub> HPO <sub>4</sub>	1840	0.1	0.184

**Table 3: Vitamin stock solution for medium M4 and M7**

All three vitamin solutions are combined to make a single vitamin stock solution.

	Amount made up to 1 litre of deionised water (mg)	Amount of vitamin stock solution added to prepare medium M4 and M7 (ml/l)	Final concentrations in test solutions M4 and M7 (mg/l)
Thiamine hydrochloride	750	0.1	0.075
Cyanocobalamin (B12)	10	0.1	0.0010
Biotine	7.5	0.1	0.00075

### **References**

- BBA (1995) Long-term toxicity test with *Chironomus riparius*: Development and validation of a new test system. Edited by M. Strelake and H. Köpp. Berlin 1995.
- Elendt, B.P. (1990) Selenium deficiency in Crustacea. *Protoplasma*, 154: 25-33.
- Elendt, B.P. and W.-R. Bias (1990) Trace nutrient deficiency in *Daphnia magna* cultured in standard medium for toxicity testing. Effects on the optimization of culture conditions on life history parameters of *D. magna*. *Water Research*, 24: 1157-1167.

ANNEX 3PREPARATION OF FORMULATED SEDIMENTSediment composition

The composition of the formulated sediment should be as follows:

Constituent	Characteristics	% of sediment dry weight
Peat	Sphagnum moss peat, as close to pH 5.5-6.0 as possible, no visible plant remains, finely ground (particle size $\leq 1$ mm) and air dried	4 - 5
Quartz sand	Grain size: > 50% of the particles should be in the range of 50-200 $\mu\text{m}$	75 - 76
Kaolinite clay	Kaolinite content $\geq 30\%$	20
Organic carbon	Adjusted by addition of peat and sand	2 ( $\pm 0.5$ )
Calcium carbonate	$\text{CaCO}_3$ , pulverised, chemically pure	0.05 - 0.1
Water	Conductivity $\leq 10 \mu\text{S/cm}$	30 - 50

Preparation

The peat is air dried and ground to a fine powder. A suspension of the required amount of peat powder in deionised water is prepared using a high-performance homogenising device. The pH of this suspension is adjusted to  $5.5 \pm 0.5$  with  $\text{CaCO}_3$ . The suspension is conditioned for at least two days with gentle stirring at  $20 \pm 2^\circ\text{C}$ , to stabilise pH and establish a stable microbial component. pH is measured again and should be  $6.0 \pm 0.5$ . Then the peat suspension is mixed with the other constituents (sand and kaolin clay) and deionised water to obtain an homogeneous sediment with a water content in a range of 30–50 per cent of dry weight of the sediment. The pH of the final mixture is measured once again and is adjusted to 6.5 to 7.5 with  $\text{CaCO}_3$  if necessary. Samples of the sediment are taken to determine the dry weight and the organic carbon content. Then, before it is used in the chironomid toxicity test, it is recommended that the formulated sediment be conditioned for seven days under the same conditions which prevail in the subsequent test.

Storage

The dry constituents for preparation of the artificial sediment may be stored in a dry and cool place at room temperature. The formulated (wet) sediment should not be stored prior to its use in the test. It should be used immediately after the 7 days conditioning period that ends its preparation.

References

OECD Guideline 207 (1984) Earthworm, Acute Toxicity Test.

Meller, M., Egeler, P., Roembke, J., Schallnass, H., Nagel, R. and B. Streit (1998) Short-term toxicity of lindane, hexachlorobenzene and copper sulfate on tubificid sludgeworms (*Oligochaeta*) in artificial media. *Ecotox. Environ. Safety*, 39: 10-20.

ANNEX 4**CHEMICAL CHARACTERISTICS OF AN ACCEPTABLE DILUTION WATER**

<b>SUBSTANCE</b>	<b>CONCENTRATIONS</b>
Particulate matter	< 20 mg/l
Total organic carbon	< 2 mg/l
Unionised ammonia	< 1 µg/l
Hardness as CaCO <sub>3</sub>	< 400 mg/l*
Residual chlorine	< 10 µg/l
Total organophosphorus pesticides	< 50 ng/l
Total organochlorine pesticides plus polychlorinated biphenyls	< 50 ng/l
Total organic chlorine	< 25 ng/l

\* However, it should be noted that if there is an interaction suspected between hardness ions and the test substance, lower hardness water should be used (and thus, Elendt Medium M4 must not be used in this situation).

ANNEX 5GUIDANCE FOR MONITORING EMERGENCE OF CHIRONOMIDS

Example of a breeding cage:

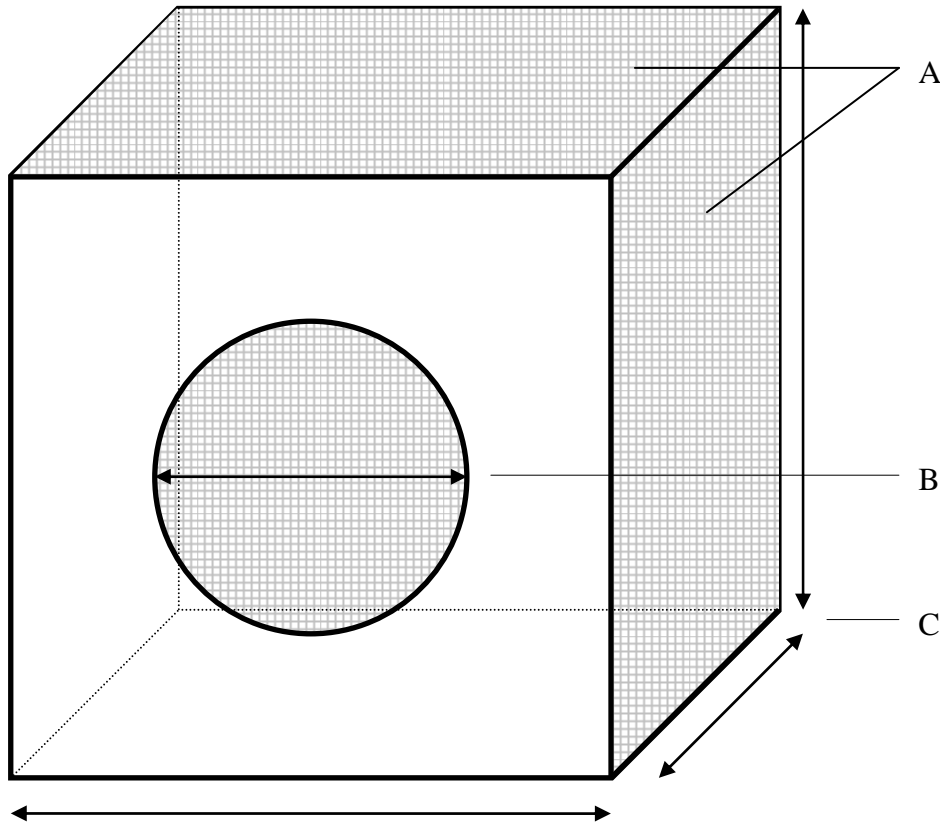

- A: gauze on the top and at least one side of the cage (mesh size ca. 1 mm)
- B: aperture for placing the emerged adults inside the breeding cage and to remove the laid egg ropes from the crystallization dishes (not shown in this graphic)
- C: breeding cage size minimum 30 cm length, 30 cm height and 30 cm width

Example of a test vessel:

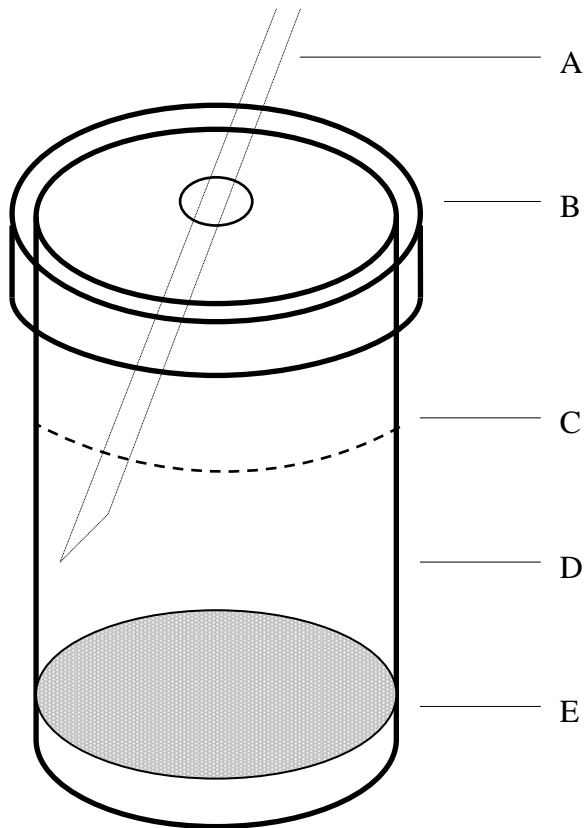

- A: Pasteur Pipette for air supply of the overlying water
- B: glass lid to prevent emerged midges from escaping
- C: water surface layer
- D: test vessel (glass beaker minimum 600 mL)
- E: sediment layer

Example of an exhauster for capturing adult midges (arrows indicate air flow direction):

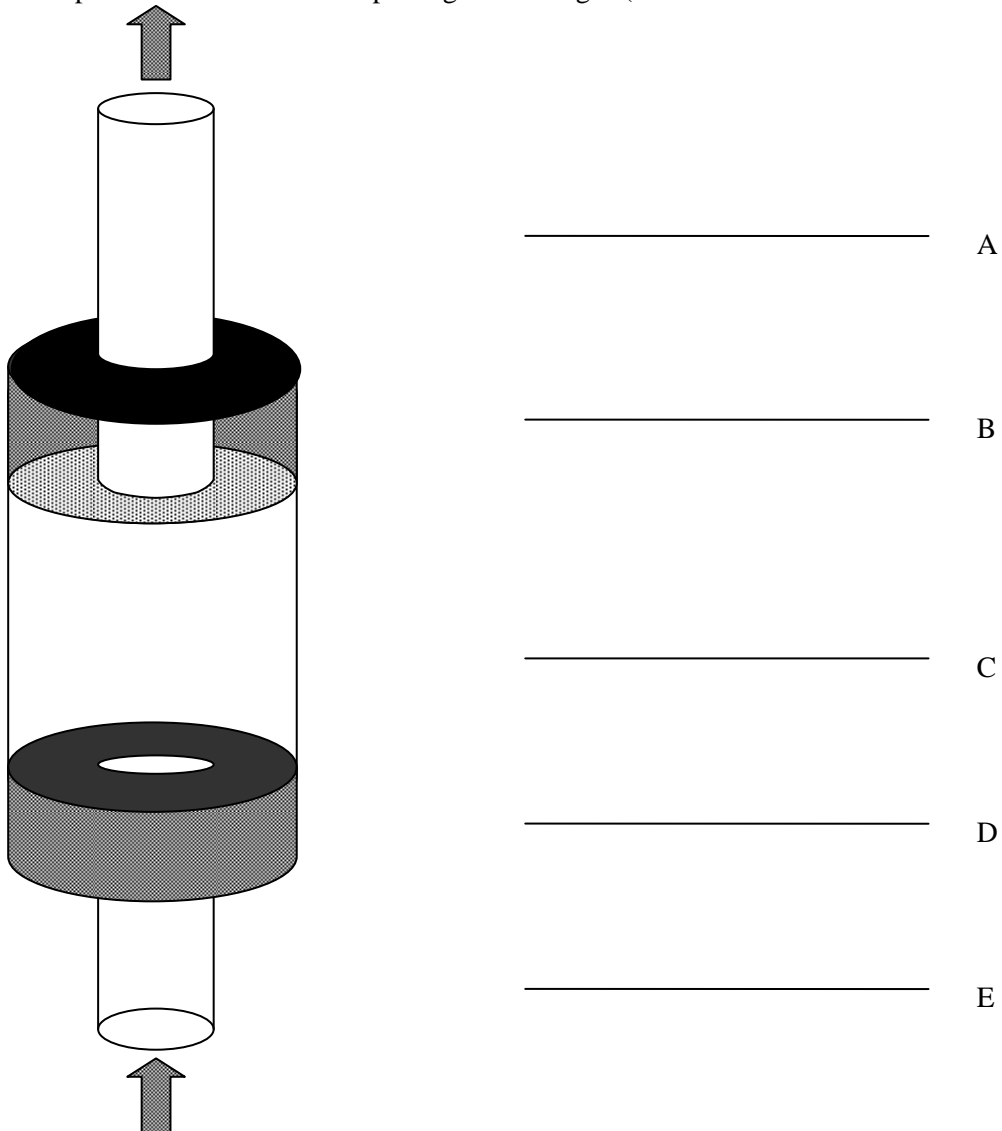

- A: glass tube (inner diameter ca. 5 mm) connected to a self-priming pump
- B: cork of vulcanised rubber, perforated with glass tube (A). On the inside, the opening of glass tube (A) is covered with some cotton and a gauze (mesh size ca. 1 mm<sup>2</sup>) to prevent damaging the midges when they are sucked into the exhauster
- C: transparent container (plastic or glass, length ca. 15 cm) for captured midges
- D: cork of vulcanised rubber, perforated with tube (E). To release midges into the breeding cage, cork D is released from container C
- E: tube (plastic or glass, inner diameter ca. 8 mm) to collect adult midges from vessel

Schematic presentation of a life-cycle test:

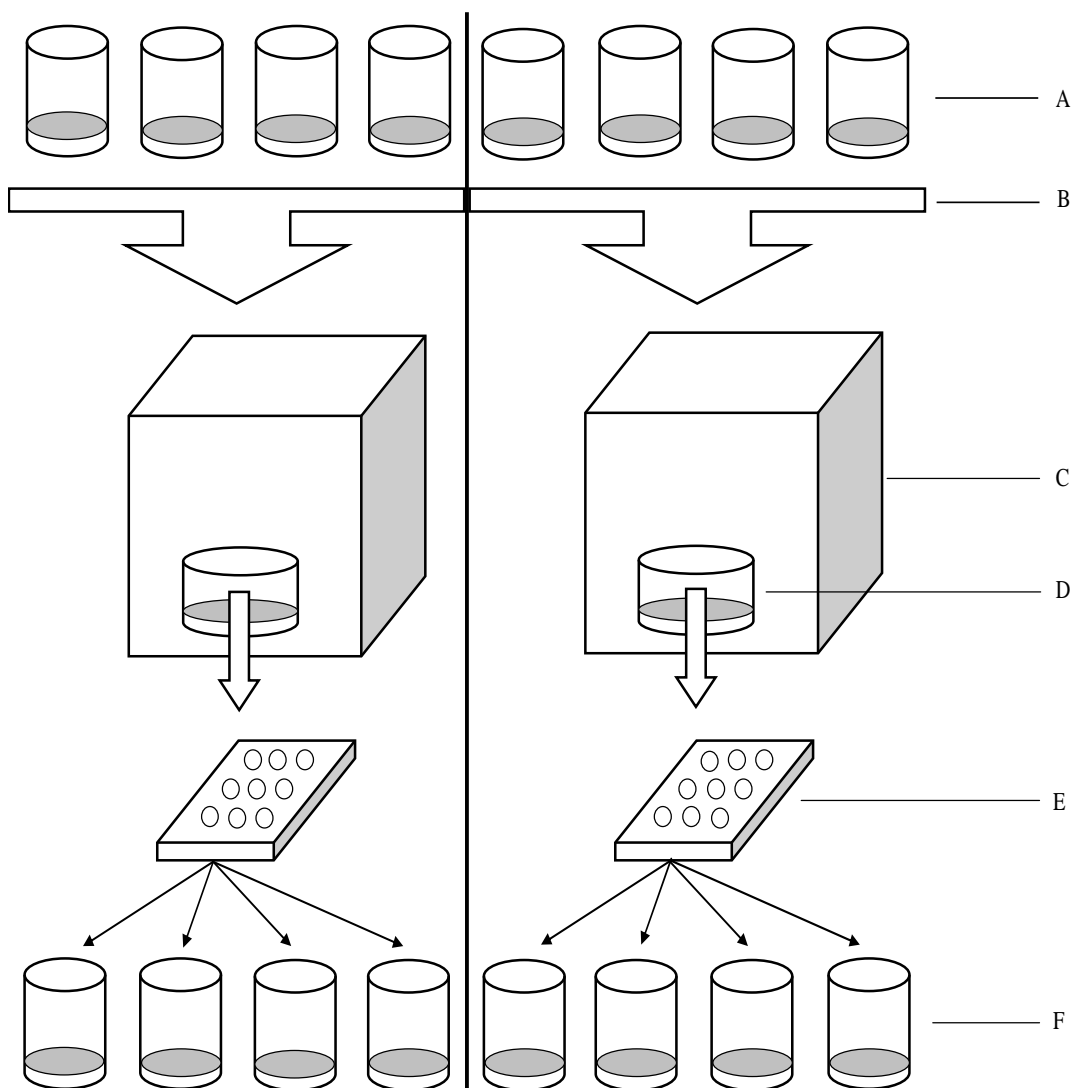

- A: 1<sup>st</sup> generation – test vessels containing a sediment-water system, eight replicates, 20 first instar larvae per vessel
- B: four test vessels for each breeding cage, A and B
- C: breeding cages (A and B) for swarming, mating and oviposition
- D: crystallisation dishes for deposition of egg ropes
- E: micro plates, one well for each egg rope
- F: 2<sup>nd</sup> generation – test vessels containing a sediment-water system, eight replicates, 20 first instar larvae per vessel