

Unclassified

DSTI/ICCP/TISP(2002)13/FINAL



Organisation de Coopération et de Développement Economiques
Organisation for Economic Co-operation and Development

03-Nov-2003

English - Or. English

**DIRECTORATE FOR SCIENCE, TECHNOLOGY AND INDUSTRY
COMMITTEE FOR INFORMATION, COMPUTER AND COMMUNICATIONS POLICY**

Working Party on Telecommunication and Information Services Policies

THE BENEFITS AND COSTS OF STRUCTURAL SEPARATION OF THE LOCAL LOOP

**DSTI/ICCP/TISP(2002)13/FINAL
Unclassified**

English - Or. English

JT00152896

Document complet disponible sur OLIS dans son format d'origine
Complete document available on OLIS in its original format

FOREWORD

In June 2003, this report was presented to the Working Party on Telecommunications and Information Services Policy (TISP). It was recommended to be made public by the Committee for Information, Computer and Communications Policy in October 2002.

The report was prepared by Dr. Patrick Xavier (University of Swinburne, Australia), Mr. Steven Dounoukos (Gilbert and Tobin, Australia), and Mr. Dimitri Ypsilanti (OECD Secretariat). It is published on the responsibility of the Secretary-General of the OECD.

Copyright OECD, 2003

Applications for permission to reproduce or translate all or part of this material should be made to:

Head of Publications Service, OECD, 2 rue André-Pascal, 75775 Paris Cedex 16, France.

TABLE OF CONTENTS

FOREWORD	2
MAIN POINTS	4
THE BENEFITS AND COSTS OF STRUCTURAL SEPARATION OF THE LOCAL LOOP	7
INTRODUCTION	7
The rationale for structural separation of the local loop	7
Framework of analysis	10
Structure of the paper	12
THE NATURE AND SCOPE OF STRUCTURAL SEPARATION	12
The LoopCo proposal	12
The NetCo proposal	15
Alternative distribution companies (ADCos)	16
Voluntary separation	17
IS STRUCTURAL SEPARATION NECESSARY?	18
Is structural separation necessary?	18
HOW WILL TECHNICAL AND INVESTMENT PROBLEMS BE RESOLVED?	21
The need for investment in the local loop	21
What technical problems will be faced and how will they be resolved?	22
Demand uncertainty and network design	23
What incentives will be put in place to ensure the necessary investment and innovation to upgrade the local loop?	24
IMPACT ON COSTS, CONSUMERS AND REGULATION	25
How will impacts on consumers be addressed?	25
What changes in regulation will be needed?	26
WEIGHING BENEFITS AGAINST COSTS	26
Are the benefits of structural separation demonstrably in excess of the costs?	26
The benefits of structural separation	27
The costs of structural separation	28
What is the policy position of governments/authorities that have considered the use of structural separation?	30
CONCLUSION	32
NOTES	33

MAIN POINTS

Five years ago, a large number of OECD countries opened their telecommunication markets to full, facilities-based competition. For some, competition has been in place for a longer period. The outcome of market opening has been unambiguously positive. Prices have declined, quality has improved, new services have developed and consumers now have a wide choice of operators. Nevertheless, while competition has developed in long-distance markets, it has been slower to develop for access and for local voice services. The share of subscriber lines taken by new entrants has not, in most OECD countries, been high.¹ Problems faced by new entrants in obtaining access to the network facilities of incumbents have led to calls for structural remedies on incumbents, and in particular the separation of the local loop from services. However, it is important to realise that the period in which new entrants have had to compete has not been long: many of the important policies needed to supplement the introduction of competition, such as number portability, carrier selection and pre-selection, and local loop unbundling, were implemented only recently. In addition, there are new technologies are now emerging which should help in generating more competition. Wireless LANs, voice over DSL and high-speed mobile services may eventually serve to create conditions in which competition for access to networks and local voice services can flourish.

This paper is aimed at responding to arguments that have been made about the necessity and benefits of structural separation of the telecommunications local loop. It is an attempt to strike a balance by stressing that in fact many of the benefits of structural separation are unquantifiable and, indeed, conjectural, while the costs of this severe measure are more certain and substantial.

This paper is not about structural separation in general, nor about structural separation in telecommunications in general – rather it is about the “vertical” separation of the competitive network services from the (presumed non-competitive) local loop services. While this paper concludes that the case for vertical structural separation is not compelling, this does not necessarily reflect on the desirability of other forms of separation in the telecommunications industry (such as separation of cable infrastructure from the telecommunications incumbent). However, even in such cases, separation cannot be justified without careful cost-benefit analysis and a review of competition in the market.

The blame for the problems relating to access and the disappointingly slow progress of local loop unbundling (LLU) has been attributed by some (especially the new entrant operators) to the incumbents’ anti-competitive conduct. Incumbents have been accused of engaging in anti-competitive activities such as “price-squeezing”, delays and cost creation, of offering an unattractive mix of exchanges for co-location, and of exaggerating the difficulties of installing the requisite equipment. Indeed, the incumbents’ competitors argue that the use of such tactics is only to be expected since an inherent conflict of interest exists when a vertically integrated incumbent operates as both supplier and competitor in the local exchange market.

The concern with facilitating the availability, cost and take-up of broadband has raised the stakes in regard to LLU. This is because LLU would allow competing telecommunications operators to ‘co-locate’ their equipment in the exchanges of the incumbent and thus gain direct access to the copper loop that goes to nearly every home and business. Through digital subscriber line (DSL) technology, LLU would allow telecommunications operators to provide advanced services to customers without having to build a new local access network.

Supporters of structural separation of the local loop argue that it would: bring the incumbent's incentives into alignment with a non-integrated carrier, thereby guaranteeing non-discriminatory access to (components of) the incumbent's networks and thereby promoting competitiveness in turn promote innovation; by promoting access and LLU (such as that required for the delivery of high-speed Internet) either by new entrants or by the incumbent which would now be under increased pressure to do so (to avoid new entrants acquiring the competitive edge); create a level playing field by forcing the incumbent's wholesale arm to deal with its retail arm on the same terms that it deals with any other retail competitor (implicitly solving interconnection issues as well); allow the management of a structurally separated incumbent to focus on the wholesale portion without the need to consider the impact of its policies on the retail division, and which should improve efficiencies; allow regulators to focus on the wholesale network to guarantee service quality, network reliability, and access to essential network facilities at cost-based prices; be simple compared to behavioural remedies; be effective, while behavioural regulation that runs counter to an incumbent's inherent incentives cannot be fully effective; improve information and help eliminate cross-subsidisation; and reduce the need for regulation because the change in incentives decreases the need for government oversight.

With the LoopCo approach, ownership and control of the incumbent's access assets and business – primarily the local loop – would be separated from its non-access business and activities and transferred to a new company, LoopCo. This new company would then provide wholesale access services to other companies at a regulated price. The “RetailCo” incumbent would then compete for all non-access services and would contract with LoopCo for its wholesale services, as any other company would.

The NetCo proposal involves separating an incumbent's access and non-access networks into a separate “network” company that then treats all retail operators in an equivalent manner.

The so-called “ADCo” proposal involves club or joint ownership of a “carriers’-carrier”.

While seemingly simple in concept, in fact structural separation of the local loop is far from simple to implement. There can be a formidable range of difficulties and a wide range of questions to be answered. And the onus is fairly placed on the proponents of structural separation to provide persuasive answers that prove the drastic action they call for is necessary.

- What is the nature and scope of the structural separation being called for? Precisely what is involved in structurally separating an incumbent operator? In other words, since “the devil can be in the details”, have the details of structural separation been clearly specified?
- What problem(s) is structural separation meant to be addressing? Is structural separation necessary?
- What technical problems will be faced and how will these problems be resolved?
- What impacts will structural separation have on investment and innovation to upgrade the local loop and how will any problems in this regard be resolved?
- How would a structurally separated “NetCo” or “LoopCo” operate and be managed?
- How would a structurally separated “NetCo” or “LoopCo” be regulated? What changes in regulation will be needed?
- How will cost-increasing impacts of structural separation be contained? Are the benefits of structural separation demonstrably in excess of the costs?
- How will impacts on consumers be addressed?
- What is the policy position of authorities that have considered the use of structural separation?
- What evidence can be tabled that structural separation is the most cost-effective approach to achieving the desired effects?

The arguments that structural separation of the local loop is necessary are inconclusive. The issues and unanswered questions raised in this paper cast serious doubt over whether there is yet an adequately detailed model for the structural separation of incumbent carriers that can or ought to be supported.

There is uncertainty about the extent to which structural separation would result in changing the incentives of the incumbent towards facilitating competition. The problems of co-ordinating investment between the wholesale and retail parties could be considerable. The effect might be, in the worst case, to delay or even impede network upgrading, including the extension of fibre closer to the customer. Mandatory separation would threaten the various efficiencies enjoyed by an integrated firm, including economies of scale and scope. There would also be considerable one-off costs of divestment.

The impact on consumers is uncertain. If competition strengthens significantly, prices could fall, and innovation and quality of service improve. But there is inadequate evidence to generate confidence about the extent to which this will happen. Moreover, the significant costs that structural separation would generate are likely to be passed on to consumers resulting in price increases.

The paper concludes that the structural separation approach of the local loop is risky with benefits that seem limited, uncertain and indeed, conjectural, and with potentially significant costs including potentially adverse effects on network development. Certainly, there is little evidence that benefits would be convincingly in excess of costs.

Against such an assessment of structural separation proposals, it would seem sensible to persevere with improvements to the current regulatory approach, backed by sanctions to deal with anti-competitive discrimination.

THE BENEFITS AND COSTS OF STRUCTURAL SEPARATION OF THE LOCAL LOOP

INTRODUCTION

The rationale for structural separation of the local loop

This paper is not about structural separation in general, nor about structural separation in telecommunications in general. Rather it is about the “vertical” separation of the competitive network services from the (presumed non-competitive) local loop network. While this paper concludes that the case for vertical structural separation is not compelling, this does not reflect on the desirability of other forms of separation in the telecommunications industry (such as separation of cable infrastructure from the telecommunications incumbent).

In recent years, the most difficult issue that regulators in OECD countries have had to address has concerned access to facilities of incumbents by new entrants – facilities that new entrants have viewed as essential to develop their markets and compete with the incumbent. The issue of access has been at two related levels: *i*) access has encompassed interconnection; *ii*) it has encompassed physical access to network resources. The first type of access issue has raised questions relating to the price of interconnection (access charges) and how to ensure these prices are non-discriminatory and cost-based. The second form of access has included issues such as unbundling of local loops² (LLU), collocation and access to rights of way.

The issue of access is viewed by regulators and new entrants as essential to the success of liberalisation and the creation of competition. Emphasis has been placed in particular on facilitating access to the local network of incumbents both for new entrants but also for Internet Service Providers (ISPs) who often do not have their own network resources. Incumbents, on the other hand, have often been accused of trying to discourage access. This can take place through high prices for interconnection, through delaying tactics and high prices for unbundling of local loops, and through their policy for collocation or for restricting rights of way.

The primary source of the problem is commonly considered to be that a vertically integrated incumbent has powerful advantages³ (arising for a large part from a bottleneck monopoly in the local loop⁴) that confers ability to leverage its dominance into retail services. The incumbent telecommunication operators in nearly all OECD countries have enjoyed a long period as a monopoly, during which they were able to build up their local telecommunication infrastructure as well as their customer base. Moreover, a vertically integrated telecommunications operator has strong incentives to use its powerful advantages and all the tools at its disposal, whether legal, technical or economic, to delay, to lower the quality, or raise the price of access.

The concern with facilitating the availability, cost and take-up of broadband⁵ has raised the stakes in regard to LLU. This is because LLU would allow competing telecommunications operators to “co-locate” their equipment in the exchanges of the incumbent and thus gain direct access to the copper loop that goes to nearly every home and business. Through digital subscriber line (DSL) technology, LLU would allow telecommunications operators wanting to provide advanced services to reach customers without having to build a new network. The issue affects most operators since, even where alternative telecommunications operators have their own “backbone” networks, they will nevertheless need to link up with the incumbent’s network in some areas.

The ability of new entrants to install their own equipment (with, accordingly, the possibility of introducing innovative technology rather than being restricted to the standards of incumbents’ technology) would exert pressure on the incumbent to itself innovate. This would help to address the growing concern over the slow progress incumbents are considered to have been making in regard to modernising the local loop for broadband. Incumbents could be deterred from installing ADSL technology because this could result in a decline in revenue from other data products. This could be particularly true for older and slower products, such as ISDN service, which can reap much higher margins for the incumbent than ADSL. The incumbent could also perceive a risk from the emergence of reliable voice technology on ADSL lines since this could see customers cancelling their existing phone lines that yield significant revenue. Also, there is the loss of revenue from potential line rental due to the reduction in demand for the second lines required by a growing number of customers for dial-up Internet.

Some attribute the blame for the disappointingly slow progress of LLU thus far on regulators, for not being vigorous enough in enforcing LLU requirements.⁶ Others, especially the new competitors, blame anti-competitive conduct of the incumbents. They have accused incumbents of engaging in anti-competitive activities such as “price-squeezing”, delays and cost creation, of offering an unattractive mix of exchanges for co-location, and of exaggerating the difficulties of installing the requisite equipment. Indeed, the incumbents’ competitors argue that the use of such tactics is only to be expected since an inherent conflict of interest exists when an incumbent operates as both, supplier and competitor in the local exchange market. They point out that the incumbent, especially its retail division, would have strong incentives to delay the provision of unbundled DSL, since this allows competitors to undermine its highly profitable business of leasing dedicated lines, including ISDN, to businesses.

Infrastructure competition is costly, particularly when costs beyond infrastructure deployment such as billing, marketing, etc., are taken into account.⁷ The changed stock market sentiment towards telecommunications operators, wherein funding for telecommunications infrastructure has become more difficult, is adding to concerns. There are now more questions and less confidence relating to the ability of cable networks, and other alternative technologies such as broadband fixed wireless, satellite and third-generation wireless, to provide an alternative end-to-end telecommunications infrastructure that would enable the incumbent’s fixed-line “local loop” to be bypassed.

Calls for structural separation

Some despair that even more intensive application of the present “behavioural” regulation approach will make an incumbent treat all operators (including its own downstream operations) equivalently. Since the integrated firm has strong incentives – and the ability – to discriminate (and to be constantly developing new tactics for delaying access), the regulator is likely to always be “catching up” with the anti-competitive tactics of incumbent firms.

All this is strengthening calls for structural separation – involving ownership separation of the retail and wholesale activity of the incumbent carrier.⁸ The incumbent telecommunications company would be separated into a “retail” company to sell services to end-user customers, and a wholesale company that owns lines and wires and sells access to all communications providers on equal terms and conditions. Proponents of structural separation argue that a separated local loop company under separate ownership, would view all competing operators as customers, rather than competitors. It would have the incentive to facilitate access to its facilities. And it would have incentives to innovate to better serve all of its customers’ needs, rather than always having to also consider the commercial interests of its own downstream operations.

Structural separation in telecommunications is in fact not a new idea. It has been applied in the past, and previous measures have included:

- Accounting, functional and corporate separation.
- Separation into regional operators.
- Separation of local from long-distance services.⁹
- Separation of local and mobile services.
- Separation of local and broadband/advanced services.¹⁰
- Separation of an incumbent into smaller, vertically integrated, carriers.

The application of these measures was examined in an earlier OECD report¹¹ and will not be repeated here. This paper also does not focus on the structural separation between ownership of telecommunications and cable TV operators.¹²

The present paper focuses on current proposals relating to the separation of the incumbent’s wholesale-retail operations¹³ and, in particular, the proposal for separation of the local loop. This “LoopCo” proposal¹⁴ is not mentioned in the earlier OECD report, and indeed, has not been adopted in any OECD member country.

The difficulties arising from access have led to arguments that the incumbent public telecommunication operators be required to structurally separate their service and other activities from their local telecommunication infrastructure. Specifically, the suggestion is that the local loop (the last mile) that connects customers to the incumbent’s network and services should be owned and operated by a structurally separate entity. Access to the network resources of this entity, essentially the copper local loop, would then be made available to any entity on the same terms and conditions (*i.e.* on a non-discriminatory basis).

Supporters of structural separation argue that it would:

- Bring the incumbent’s incentives into alignment with a non-integrated carrier, thereby guaranteeing non-discriminatory access to (components of) the incumbent’s networks and thereby promoting competitiveness.
- By promoting access and LLU in turn promote innovation (such as that required for the delivery of high-speed Internet) either by new entrants or by the incumbent which would now be under increased pressure to innovate (to avoid new entrants acquiring the competitive edge).

- Create a level playing field by forcing the incumbent's retail arm to deal with its wholesale arm on the same terms that it deals with any other competitor (implicitly solving interconnection issues as well).
- Eliminate conflict between retail and wholesale divisions in a company in terms of pricing and marketing.
- Allow regulators to focus on the wholesale network to guarantee service quality, network reliability, and access to essential network facilities at cost-based prices.
- Be simple compared to behavioural remedies.
- Be effective, while behavioural regulation that runs counter to an incumbent's inherent incentives, cannot be fully effective.
- Improve information and help eliminate cross-subsidisation.
- Reduce the need for regulation because the change in incentives decreases the need for government oversight.

Many are unconvinced, however, that structural separation is necessary. For instance, the FCC and Oftel, the US and UK telecommunications regulators, have expressed their reservations. To cite other sceptics, Crandall and Sidak¹⁵ are particularly dismissive of the case for structural separation:

“Mandatory structural separation is unnecessary because the putative benefits that it would produce are in fact non-existent. No malady exists for mandatory structural separation to cure. Mandatory structural separation, however, would clearly impose substantial costs on the ILECs (Incumbent Local exchange Carriers). Because those costs are unnecessary to advance any public interest objective, they are also social costs – a waste of economic resources.” (p.74)

Others, while accepting that a malady does exist, e.g. Cave,¹⁶ point to the difficulties of quantifying the costs and benefits of structural separation and of assessing whether the benefits conclusively outweigh the costs involved to warrant supporting the approach.

Many who doubt the need for structural separation question whether current forms of regulation have been fully developed, effectively applied and given enough time to work for them to be legitimately dismissed as ineffective. Indeed, Gabel concludes from his assessment of structural separation proposals that:

*“The only sensible approach to public policy in light of the lack of competition evolving in the provision of local telecommunication services is to continue the current regime under which local services are regulated ...”.*¹⁷

Framework of analysis

This paper examines the arguments that underlie proposals for structural separation, and in particular arguments that the local loop be separated from a vertically integrated telecommunication incumbent to form what has been referred to as a 'LoopCo'. Structural separation can generate substantial costs and is a severe change from current approaches to regulation. To warrant support, evidence must be tabled about its benefits and the extent to which it would indeed achieve its promised aims. Moreover, there must be a

persuasive case for structural separation based on a benefit-cost analysis – whether (and by how much) the benefits exceed the costs.¹⁸

Not only should benefits be demonstrably in excess of costs, there should also be sufficient evidence that structural separation is the most cost-effective approach to achieving the desired effects and that a less-disruptive behavioural remedy that achieves the same goal at lower cost is not available.

This approach is consistent with the OECD's position on the question of structural separation. In 2001, the Council of the OECD recommended that member countries, when faced with a situation in which a regulated firm operates simultaneously in non-competitive and potentially competitive activities, "carefully... to balance the benefits and costs of structural measures against the benefits and costs of behavioural measures".¹⁹

There are a range of questions about structural separation that need to be answered, some of which are listed below:

- What is the nature and scope of the structural separation being called for? Precisely what is involved in structurally separating an incumbent operator? In other words, since "the devil can be in the details", have the details of structural separation been clearly specified?
- What problem(s) is structural separation addressing? Is structural separation necessary?
- What technical problems will be faced and how will these problems be resolved?
- What impacts will structural separation have on investment and innovation to upgrade the local loop and how will any problems in this regard be resolved?
- How would a structurally separated "NetCo" or "LoopCo" operate and be managed?
- How would a structurally separated "NetCo" or "LoopCo" be regulated? What changes in regulation will be needed?
- How will cost-increasing impacts of structural separation be contained?
- How will impacts on consumers be addressed?
- Are the benefits of structural separation demonstrably in excess of the costs?
- What is the policy position of those authorities that have considered the use of structural separation?
- What evidence can be tabled that structural separation is the most cost-effective approach to achieving the desired effects?

Structure of the paper

Following this introduction, Section 2 examines the nature and scope of specific forms of structural separation currently being proposed, such as “NetCo” and “LoopCo”. While seemingly simple in concept, in fact, structural separation is far from simple to implement. There can be a formidable range of difficulties, including technical ones. Section 3 challenges the claim that structural separation is necessary. Section 4 explores technical problems and how they would be resolved. It also examines the likely impact of structural separation on investment and innovation in the local loop. Section 5 examines the impact of structural separation on costs, consumers and regulatory change. Section 6 examines the task of weighing the benefits of structural separation against its cost and concludes that the task is fraught with difficulty. The benefits are uncertain while the costs are potentially significant. The assessment is not convincingly in favour of structural separation. Finally Section 7 presents the paper’s conclusions and recommendations. The paper recommends that the current regulatory regime (appropriately improved and backed with sanctions to deal with discrimination by an incumbent) should be persevered with.

THE NATURE AND SCOPE OF STRUCTURAL SEPARATION

The LoopCo proposal

Under the LoopCo approach, ownership and control of the incumbent’s access assets and business -- primarily the local loop -- would be separated from its non-access business and activities and transferred to a new company, LoopCo. This new company would then provide wholesale access services to other companies at a regulated price. The incumbent would then compete for all non-access services and assets, such as access to the local loop, and would contract with LoopCo for its wholesale services as any other company would, as illustrated by Figure 1.

Figure 1. Ownership separation – LoopCo proposal

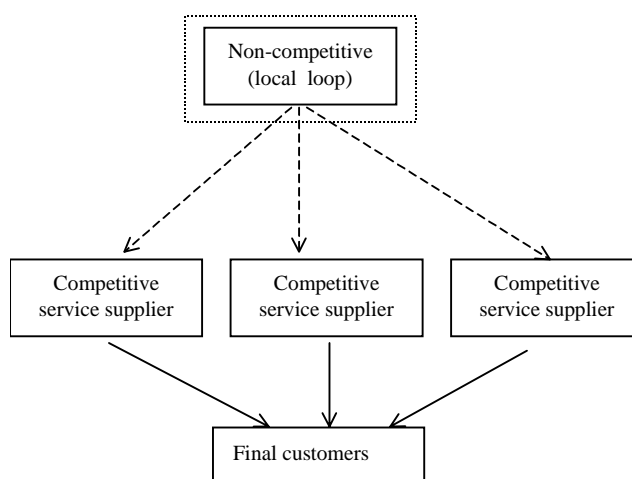

There are a number of LoopCo proposals²⁰ and variants, and a number of models that might be considered. Key variables differentiate one model from the other, including issues such as ownership and control of LoopCo, the type of corporate governance and market regulation LoopCo would be subjected to, etc.

Three main approaches to LoopCo are:

- **Approach 1:** Where LoopCo is privately owned and competitive. In this model, other companies could come in with their own local loop infrastructure, as long as they were not dominant within the market when in vertically integrated form. New entrants that are vertically integrated but not dominant within the market would be permitted.
- **Approach 2:** Where LoopCo is a company with a monopoly over the local loop and would be regulated. A country that is privatising its telecommunications market, but that aims to keep the local loop in government ownership even after privatisation of the incumbent, might adopt this approach.
- **Approach 3:** Where LoopCo has a monopoly over the local loop but is a consortium owned by all the telecommunications service providers in the market. Upgrades to the local loop would occur as necessary and when agreed to by all the members of the consortium.

It is possible to work through all three approaches during the process of privatisation and deregulation. However, in the context of OECD countries, Approach 1 is likely to be considered the preferred approach as it involves a fully privatised and independent company, and seeks to rely on a fair and competitive market to drive innovation, service development and price reduction.

Supporters of structural separation do not usually specify which of these approaches should be preferred, and so it could reasonably be assumed that this is contingent on the market and country in which it is to be applied. If this is the case, it is pertinent to consider what considerations would be appropriate in choosing one approach over another when faced by a specific market or regulatory environment? Depending on what approach is adopted, various factors would need to be considered, including:

- Precisely how LoopCo would be constituted and operate.
- LoopCo's commercial viability.
- LoopCo's incentives to innovate.
- LoopCo's size and overheads, ongoing and maintenance costs.
- LoopCo's cash flow.
- The services and value-adding LoopCo would (be permitted to) develop.
- Which operators would be permitted to compete against LoopCo.
- Other factors relevant to both the incumbent and LoopCo.

Two main options for constituting LoopCo are:

- **Option 1:** Wherein LoopCo would control the copper wires and only the Main Distribution Frame (MDF) within the switch (see Diagram A).
- **Option 2:** Wherein LoopCo would control the copper wires and the entire switch.

Diagram A

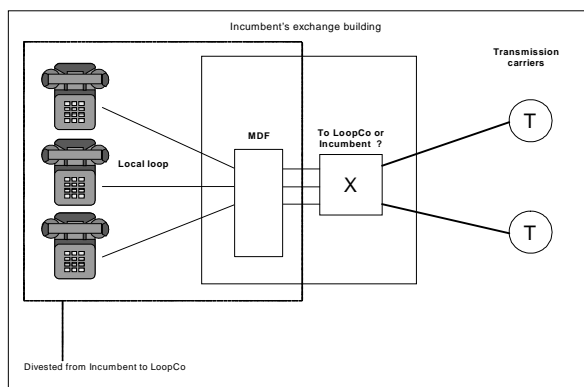

If the aim of structural separation is to separate the non-competitive assets –the local access network – from the incumbent, Option 1 emerges as the preferable approach.

Option 1 takes a minimalist approach and would have the advantage of limiting the assets to be removed from the incumbent. The disadvantage is that under this option, no single party would be responsible for the operation and maintenance of the switch, and this could lead to complicated and difficult dealings between parties.²¹

Also, if the aim of structural separation is to remove the non-competitive aspects of the incumbent's activities that are creating a bottleneck (and related anti-competitive outcomes), Option 1 could be said to emerge as the preferred approach. At the same time, under this option there is a need to make clear how associated services that relate to access to the local loop would be developed, and which parties may provide such services.

Option 2, by including the entire switch, would simplify the operation and maintenance of the switch. However, Option 2 creates a series of new issues such as control and use of the switch and would involve the provision of many value-added services (*e.g.* billing, value-added call options, etc.). This in turn raises questions about whether the services relating to the control and ownership of the local loop should be subject to competition in order to curtail LoopCo's power as exclusive owner and controller of the local loop and provider of related wholesale access services. This situation is not dissimilar to the current situation involving the incumbent. Further, if Option 2 is chosen, details would have to be provided as to how pricing and delivery of the services would be regulated, or to what extent LoopCo would be restricted from providing access services which relate to its control and ownership of the local loop.

The technical choice between these two options is an example of a telecommunications-specific issue that should be addressed by proponents of structural separation. Neglect of this fundamental issue undermines the operational value of any suggested approach that reflects a practical understanding of the telecommunications market.

The retail services provided by firms using LoopCo's services could be either broadband or narrowband. In either case, if facilities were to be provided at an incumbent's local exchange by an operator other than the incumbent itself, arrangements for the co-location of switches or of facilities for the provision of broadband service might be necessary. Thus, in many variants, LoopCo would provide, or facilitate the provision of, co-location space in the exchange.

Once LoopCo is operating, will the incumbent be allowed to develop its own network and re-integrate? If this is permitted, what will LoopCo be allowed to do to compete? LoopCo will need to develop value-added services to develop and maintain its business, but at that point vertical integration re-emerges. How will the pricing and regulatory policy be set up to allow LoopCo to compete? Will vertically integrated new entrants be permitted to set up new loops to compete against LoopCo? Arguments supporting structural separation must give greater attention to what the market will look like after separation and how LoopCo, the incumbent and their respective competitors might function after structural separation occurs.

These proposed arrangements raise questions about whether LoopCo would be entitled to provide conveyance services on a wholesale basis as well as access? Would it be subject to some form of rate of return or price-cap regulation, under the current regime of geographical averaging?

The issues and unanswered questions raised above generate considerable doubt over whether there is as yet an adequately detailed model for the structural separation of incumbent carriers through a LoopCo approach that can or ought to be supported.

The NetCo proposal

A proposal to establish a NetCo²² has been made in the United Kingdom and the United States (where it has been espoused particularly by AT&T²³). As articulated by British Telecom (BT), a NetCo would involve separating BT's access and non-access networks into a network company which then has arm's length and equivalent contractual arrangements with both BT's retail operations and other competitors, whether resellers or network operators.²⁴ Where it involves ownership separation, the vertical separation of the incumbent's retail and wholesale divisions to install a NetCo is illustrated by Figure 2.

Figure 2. Ownership separation – NetCo proposal

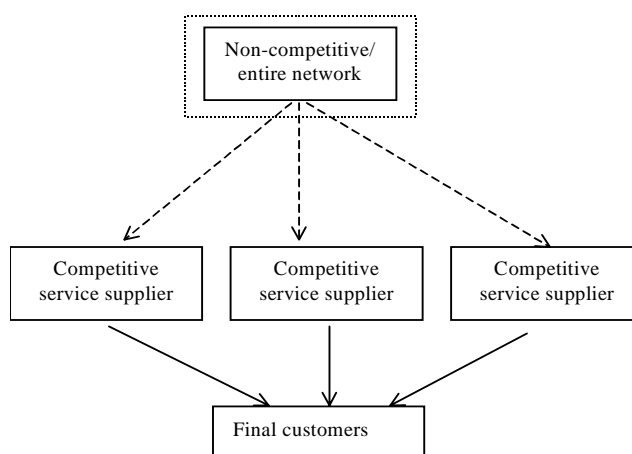

A NetCo approach would maintain economies of scale and scope and co-ordination advantages because network investment is undertaken by a single integrated network firm. However, it would nevertheless have significant disadvantages. Those who find the NetCo proposal unconvincing²⁵ point out that the NetCo structure does not address the local loop issue. Since the local loop remains integrated in NetCo, the incentive remains for NetCo to favour access to its own services, or the incumbent's DSL service. Therefore, the NetCo proposal does not address conditions allowing the leveraging of market power from bottleneck monopoly to competitive activities in NetCo. This problem is likely to persist although it may diminish as the boundary between competitive and non-competitive activities changes over time.

Co-ordination problems could be significant under a NetCo as the organisation running the network would have no relationship with customers. It seems likely that technical developments would be triggered either within NetCo itself, which would then run the risk that retailers would not be willing to invest in the marketing resources needed to sell them to customers, or in individual retail firms, which would then have to persuade NetCo that the anticipated demand for the new service is sufficient to justify what may be a very large investment. The risk that technical change would slow down seems a real one.

It is notable that, with very few exceptions, telecommunications firms of all sizes in market share have not taken the NetCo separation route.

Alternative distribution companies (ADCOs)

Another proposal made recently is for the establishment of a “carriers’-carrier”. This so-called ADCo proposal²⁶ is a very different concept from a LoopCo and involves club or joint ownership of the non-competitive activity by firms in the competitive component, as illustrated below in Figure 3.

Figure 3. Club ownership – ADCo proposal

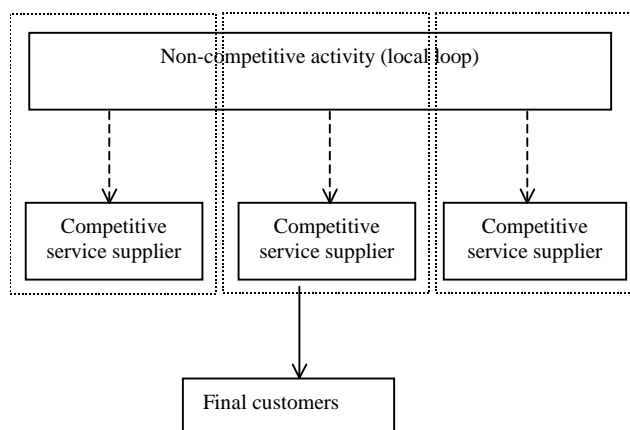

The “carriers’-carrier” is not a new concept to telecommunications. Many long-haul networks, both national and regional, are built and/or operated as a “carriers’-carrier”. Economies of scale, economies of density, and sunk costs are very important in the local exchange, where fibre deployment in metropolitan markets can be, according to one estimate, about 12 times as expensive as long-haul fibre networks.²⁷ This suggests that the most probable and viable long-term, competitive market structure involves a substantial presence by an unintegrated, but larger wholesale supplier – in other words, an ADCo – to function efficiently.

Proponents for an ADCo argue that it would deliver many of the advantages claimed for structural separation including elimination of the incentive to discriminate among rivals. Accordingly, it would reduce the need for active regulatory oversight and intervention. By maintaining a close link between the non-competitive activity and its downstream users, the non-competitive activity is kept responsive to the needs of its customers. With representation on the ADCo’s Board, members can ensure programmes to upgrade its network and deploy new technologies. In this respect, ADCo seems superior to a LoopCo since it is not clear how such network upgrading and deployment of new technologies would be ensured under a LoopCo approach.

On the other hand, the ADCo approach also has certain important drawbacks. For instance, the downstream rivals collectively have an incentive to deter new entrants and therefore, some form of intervention might still be necessary. Also, the downstream firms may be able to use their control over the non-competitive component to facilitate collusion among themselves (for example, by refusing to sell on equal terms to a downstream firm that was not complying with the collusive agreement). Another disadvantage could occur where the number of downstream firms is large since in this situation the joint ownership could result in governance problems.²⁸

Voluntary separation

Another question is whether regulators should permit voluntary structural separation. This question arises because in 1993, Rochester Telephone announced its plans for voluntary structural separation. Seven years later in the United Kingdom, BT announced that it wanted to voluntarily separate its wholesale division from its retail division.

Rochester Telephone filed a proposal with the New York State Public Service Commission (NYPSC) in February 1993, to open its Rochester, New York local exchange market to competition. After seven months of public hearings, the NYPSC approved the proposal.²⁹ Although Rochester Telephone's voluntary separation was to result in increased competition, six years later the NYPSC was to observe that "competition ha[d] yet to develop to any noticeable extent".³⁰ Rochester Telephone's voluntary separation came to an end when Global Crossing bought the company in 1999. Crandall and Sidak concluded that: "That experiment suggests that voluntary structural separation is not efficacious for developing competition in local telephony".³¹

In November 2000, British Telecom announced a restructuring plan under which it would voluntarily separate its network operations and maintenance from the other parts of its business – retail telephone, broadband, mobile and Internet services; 25% of the network company ("NetCo") would be separately listed and traded on stock exchanges. Oftel initially opposed BT's initiative to structurally separate but later agreed to allow it to proceed.

Why would a vertically integrated firm want to voluntarily structurally separate?

Some forms of separation create wealth for shareholders. This may entail selling-off a non-core part of the company or outsourcing non-core activities. The access network is a key input to retail services so incumbents are reluctant to separate this core activity. Where this has been done or contemplated, it might be due to frustration with regulation and a desire to put the cash-generating side of its business on a level playing field.

BT made it clear in announcing its intention to structurally separate that the move was, in part, a response to regulation, saying that the creation of NetCo (a fully separate company) should reduce the need for the level of regulation its retail division is subjected to.³²

Some market analysts support structural separation because they believe that the value of such a transaction would outweigh the value of lost synergies within the company. An example of where this type of separation has occurred has been the separation of mobile and PSTN service. Corporate separation can help to expose inefficiencies in an incumbent's current structure, releasing value to the benefit of shareholders and consumers. Whether this would exceed the benefits obtained by an incumbent through the synergies generated by its current structure would need to be examined, but there are significant market pressures for splitting up large conglomerates that need to be considered.

Another possible reason why a vertically integrated incumbent might want to voluntarily separate its wholesale division is that structural separation would permit this division to focus on improving its own commercial circumstances. The incumbent's wholesale division would perceive commercial value in increasing the sale of network services, including the sale of elements of this network (unbundled local loops), to competitors. While integrated with the retail division, the wholesale division's own strategy and commercial interests may be compromised by the need to consider the impact on the retail division. This is because the increased sale of wholesale access might not be so welcome to the retail side since this could erode revenue from profitable line rental, leased lines, ISDN, ISPs, etc. In pursuit of its own interests, the wholesale division could want to separate but, since the retail division generates the cash flow, it is likely to have the more persuasive voice in the boardroom.

The issue of voluntary separation is raised here also because it is sometimes argued in the structural separation debate that a structurally separated wholesale company would be unprofitable. If so, why have some companies (*e.g.* BT) voluntarily wanted to install it as part of their business plan? And why were a number of companies keen to buy the wholesale portion of BT's business? In 2001, BT received two separate and unsolicited offers to divest its fixed-line business. At the end of July 2001, a US-based consortium offered BT GBP 8 billion to buy BT's local loops through a bid vehicle called "Earthlease". Oftel, the UK telecommunications regulator, endorsed Earthlease's proposal because the consortium promised to invest GBP 500 million annually for at least seven years to accelerate the deployment of broadband services. However, BT rejected Earthlease's bid.

Less than a week after it rejected Earthlease's offer, BT received an unsolicited buyout proposal from West-Deutsche Landesbank (West LB), a state-owned German investment bank. West LB offered to buy BT's entire fixed-line infrastructure for GBP 18 billion pounds, including GBP 5 billion in cash. Again, BT declined.

BT had evidently concluded that the unsolicited proposals for voluntary divestiture would not adequately compensate the company for the value of infrastructure assets within its vertically integrated operations and the costs associated with dismantling its integrated business. BT is now solidly against structural separation, whether voluntary or mandated.

IS STRUCTURAL SEPARATION NECESSARY?

Is structural separation necessary?

To respond to this question, it is necessary to be clear about the exact problem(s) structural separation is meant to address. What evidence is there that the proposal is not, as some have suggested, an "Intrusive remedy designed to fix a problem that has not been shown to exist"?³³ And, is structural separation necessary (and the best way) to address the problem?

There is significant disagreement in the answers to these questions and the evidence is inconclusive. Some analysts consider that anti-competitive conduct by a powerful vertically integrated incumbent is the primary source of the problem. According to other analysts, the disappointing amount of LLU is the result of an ineffective regulatory regime.³⁴ And other explanations have been provided. Among these are the difficulties and high cost of successfully entering and competing in the telecommunications market. Another argue that unbundled loops available at cost-based prices do not provide a sound basis for competition. Another is that the stock market reassessment of prospects for telecommunications operators have dramatically reduced the funds available to new entrant competitors trying to enter the market. Thus, the extent to which the source of the problem is anti-competitive conduct is not clear.

Even if there is persuasive evidence of systematic discrimination, is there evidence that structural separation is the most cost-effective and practical way of addressing the problem(s)?

A common answer is that structural separation is necessary to address the ability of a vertically integrated incumbent to leverage its powerful advantages *e.g.* due to the significant economies of scale in its local loop.

Economies of scale: Large economies of scale limit the number of companies that can profitably provide local telecommunication services. At least three important sources of economies of scale can be identified in the case of telecommunications.³⁵ First, there are the traditional economies of scale associated with installing facilities – such as putting up poles, digging trenches, or laying conduit.³⁶ For example, the cost structure of the local loop involves both fixed and sunk costs and consequently is the most difficult facility for any potential competitive local exchange carrier to profitably replicate.

Most loop installations involve the use of technology for which the recoverable value of the facilities is low. Much of the cost of installation is associated with the actual labour effort and the machinery that is used to install the copper or fibre cable. Sunk or irreversible costs deter entry because they increase the risk associated with entry. Incumbent firms have a strategic advantage if the entrant must incur costs that are not part of the forward-looking opportunity costs of the incumbent. These additional costs create a barrier to entry because the incumbent firm's opportunity costs are lower than the entrants are and, therefore, the incumbent will be able to under-price potential rivals.

A second source of economies of scale is the back-office “fixed” cost of setting up a billing and operational support system. This quasi-fixed cost must be recovered from a small share of the market relative to the operations of the incumbent telephone companies.

A third source is customer acquisition costs. The economies of scale exist because any company incurs certain minimum expenses that are largely independent of the number of customers served (*e.g.* developing an advertising and marketing campaign for a particular geographic area).

In order to illustrate why economies of scale are a significant barrier to entry, Gabel focused on one of these three forms of economies of scale – those associated with facilities' installation.

The data in Table 1 indicate that the high fixed costs incurred by entrants make it very difficult for them to compete successfully with the incumbents. With a 10% market share, new entrants face unit costs eight times those of incumbents, while with a 20% market share, new entrants face monthly costs three times those of the incumbents. Only with a 50% market share are new entrants competitive with incumbents. However, a new entrant could not realistically obtain a 50% market share upon entry due to the natural reluctance of consumers to switch to an unknown and new provider from which service might not be reliable. Hence, the cost differential and, the existence of large sunk costs and economies of scale, combine to suggest that a competitive market in the provision of local telecommunication services is unlikely.

Table 1. Comparison of Incumbent and entrant monthly costs per loop**

Incumbent's market share (%)	Entrant's market share (%)	Entrant's unit cost / Incumbent's unit cost (%)
98	2	4 800
92	8	1 050
90	10	800
80	20	300
70	30	133
60	40	50
50	50	0

Source: David Gabel, "Why is there so little competition in the provision of local telecommunications services? An examination of alternative approaches to end-user access", Department of Economics, Queen's College, 21 August 2002.

Note: ** Estimates are based on the cost of a 250-pair buried copper cable in density zones of 850 to 2 550 lines per square mile.

The evidence that the incumbents' local loop manifests features that confer bottleneck monopoly power does not mean, however, that structural separation is necessarily the best solution. Alternative regulatory approaches are available. And, accordingly, the case for structural separation has to be made not only on the basis of a cost-benefit analysis but also on the basis of evidence of its superiority over these regulatory alternatives.

Broadband: A major concern is that delays in the provision of LLU and other behaviour by incumbents have placed competitors relying on access to the incumbents' network to provide broadband at a serious disadvantage. But there is a lack of persuasive evidence to support such claims. For instance, no dominance by incumbents in the broadband market has been demonstrated. And, indeed, the incumbents' share in the provision of broadband is relatively low by comparison with other areas. Such considerations weigh against the persuasiveness of arguments that structural separation is justified by significant abuse of dominance in the broadband market.

Effect of convergence: Digital convergence of technologies and the changing uses of telecommunications networks will affect the development of telecommunications regulation. Market power may be undermined in some areas. But market power may be created, maintained or increased in others. In such a state of unpredictable change, it will become increasingly difficult to define markets and, consequently, the effects of structural separation may become difficult to predict. Can there be confidence that structural separation is the appropriate approach for the new, converged telecommunications environment? In a framework of technological evolution and convergence, it will become more difficult to establish clear boundaries between infrastructures and services. Arguments supporting structural separation must give greater attention to what the market will look like after structural separation and how LoopCo, the incumbent, and their respective competitors might function after structural separation occurs.

The incumbent's local access network (*i.e.* the copper pairs connecting end-users to the closest distribution frames) is not the only technical infrastructure allowing for the provision of retail services to end-users. Other alternatives exist, such as fibre optic networks, wireless loops or upgraded cable TV networks. However, at present, in most countries, none of these alternatives can be considered to be an equivalent. Fibre optic networks are presently only competitive on upstream transmission links and, in regard to the retail distribution network, in special niches like networks connecting office buildings or a narrowly defined geographical area. Wireless loops appear most suitable to address the needs of professional clients and small firms, and are likely to remain uneconomic for serving the large majority of residential customers. Cable networks need costly upgrades for the provision of two-way telecommunications services. Moreover, the provision of high-speed services on cable involves customers

sharing the capacity of a cable channel, which means that high-speed data via cable modems does not offer the same capacity as the copper pair upgraded with DSL technologies, which is dedicated to each end-user. Additionally, in many countries cable networks do not normally have a nation-wide coverage which would allow entrants to serve the same geographic markets as incumbents, whether for traditional voice telephony retail services or new DSL services. Other innovative technologies such as the use of electricity networks do not appear to be a technically or economically viable alternative solutions at present. It appears that at present none of these alternative networks, nor even their combined use, can be considered as a nation-wide alternative to the incumbents' copper pair. However, technological change (already manifesting) itself in deployment of WI-FI and wireless LAN) will continue to alter circumstances.

HOW WILL TECHNICAL AND INVESTMENT PROBLEMS BE RESOLVED?

The need for investment in the local loop

Deployment of xDSL services over twisted wire pairs, even at relatively low data rates, requires additional equipment beyond what is in place today for narrowband services. Also, the number of subscribers that can be served by ADSL equipment directly from the central office is limited due to the loop length.³⁷ Achieving high penetration rates and providing data at above 1.5 Mb/s can be accomplished only by upgrading the telecommunications infrastructure and reducing the mean distance between the modems and the residence.

Figure 4 illustrates how ADSL can be deployed from the telephone central office. Additional equipment, in the form of a Digital Subscriber Line Access Multiplexer (DSLAM) with appropriate ADSL modems, is required to modulate the data signal onto the twisted wire pairs. A diplexer is also required to combine the voice signal with the data signal. A POTs separation filter is used at the subscriber side to separate the voice signal from the data signal.

Figure 4. Deployment of ADSL from the central office

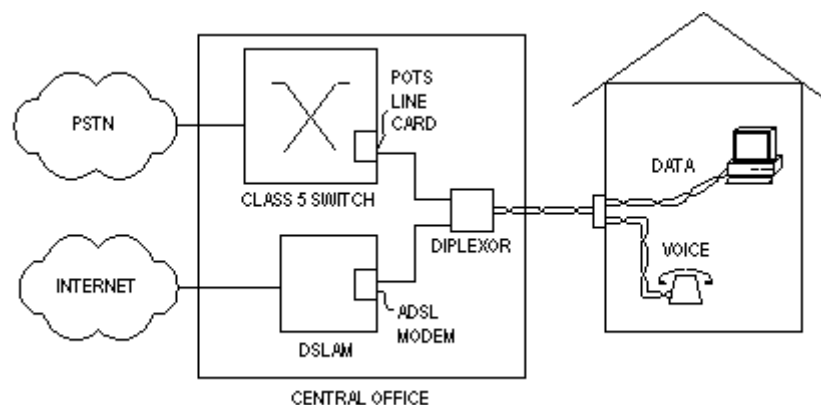
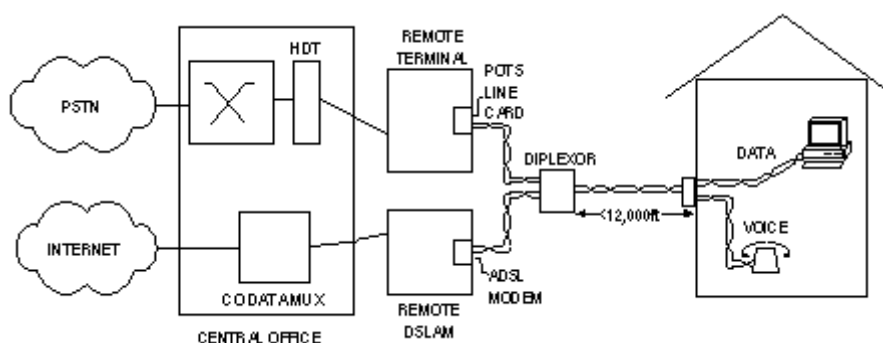

Figure 5 illustrates the deployment of DSL services from a location remote from the central office. In this example, voice services are provided from a remote terminal, which places the POTs cards closer to the subscribers, eliminating the need for large bundles of twisted wire pairs from the central office. This architecture, entitled Digital Loop Carrier (DLC), has been in place for narrowband services for many years, and in many circumstances is a cost-effective solution for providing voice services. Nevertheless, DLC equipment does not support high-speed data services and, as illustrated in Figure 5, additional equipment including a remote DSLAM with ADSL modems needs to be deployed. At the central office, packet multiplexing equipment is required, and fibre is required to interconnect the data multiplexer with

the remote DSLAM. The infrastructure in place for narrowband services, even when equipment is remotely located from the central office, does not support advanced data services without additional investment.

Figure 5. Deployment of ADSL from a remote terminal/DSLAM



The need for additional equipment for DSL service will significantly increase investment costs. Simple twisted wire pair loops have installation costs estimated at about USD 600 per subscriber, while Digital Loop Carrier and Fibre-to-the-Curb infrastructures can cost several hundred dollars more.

What technical problems will be faced and how will they be resolved?

Where would the line be drawn? Vertically integrated incumbents have themselves argued that structural separation of a highly complex vertically integrated company will be difficult, disruptive and costly.³⁸ Structural separation of telecommunications networks poses particularly intractable problems at a technical level, given the growing complexity of modern systems and the presence of intelligence in different network layers. Where, in evolving networks, do “wholesale” carriage services end and “retail” value-added services begin? Where, for instance, would regulation locate such intelligent network services as caller line identification (CLI) and call waiting-forwarding, and where would the future incentives lie for the further development of such network capabilities for a pure utility wholesale operator?

Drawing a line between services and infrastructure may also be complicated by the increasing technological sophistication in telecommunications. It may be difficult to excise particular services that are effectively embedded in the infrastructure and which could readily be characterised either as retail or wholesale activities. Infrastructure services responsibilities include planning, design, construction and operation of fixed communication networks and associated systems, and customer service, installation and repairs. The wholesale supplier sells wholesale products and services to other carriers and carriage service providers. The retail supplier provides sales and billing for residential, business and government customers, and manages other customer services such as directories and payphones.

It is possible that certain existing services, such as call centres, may need to be separated into infrastructure and services categories. Administration of an incumbent’s existing data centres and international agreements with carriage service providers would probably need to be attached to the network company. The position of certain operational components of the network would need to be examined. For example, the origination and termination of calls between the fixed-line network and mobile networks would need to be clarified.

Should an incumbent's directories be included in any separated network company, as it is arguable that they carry powerful bottleneck monopoly characteristics? If this arrangement did not eventuate, it may be necessary to develop a new regulatory regime for directories.

Difficulties could arise in the construction of regulatory definitions, which might open up new opportunities for regulatory gaming. It would also be important to ensure that new obligations of transparency and accountability did not unduly impinge on the legitimate need for the retail supplier to maintain commercial confidentiality equivalent to that enjoyed by its competitors.

Splitting up an incumbent could raise specific anomalies. It would be essential to ensure that any such anomalies are very minor, and have minimal impact on the efficiency, accessibility and competitiveness of the telecommunications sector.

And how will the boundary change as a result of technological change?

Structural separation in the telecommunications industry using the LoopCo approach requires a definition of the scope, or "border" that would be considered the local loop and related access elements of the incumbent's network to be separated. With regard to the local loop, this might only apply to the copper wires, not the local switch. Including the switch as part of what would be separated from the incumbent would result in some services being vested in the LoopCo. Therefore, it could be simpler to separate the copper wires only. If, however, the border were within the switch, where exactly would it fall?

How will problems that can arise in co-ordinating investment activities be resolved? Developments in fixed link telecommunications are likely to take the form of extending fibre from the local exchange to the kerb or to the home to enable fast broadband access. If not, standards will be limited to DSL technologies. If this investment is to be the responsibility of LoopCo, how would the vitally important investment incentives be created for LoopCo?

Demand uncertainty and network design

One of the reasons for vertical and horizontal integration is to reduce risk when there is a myriad of technological options rather than any standardised technology. This is the situation for telecommunications investment today which must consider a multitude of technologies including ATM, frame-relay, fibre, hybrid fibre-coaxial, SONET, compression, fibre, multiplexer, coaxial cables, power sources, and set-top boxes. Prudent investment involves spreading the risk of employing an appropriate combination of these technologies. The difficulty of the task is increased by the uncertain demand for new services. Firms are reluctant to invest in infrastructure modernisation if there is uncertainty regarding consumer interest in the new products supplied through the technology. Early adopters avoid making commitments to technology that will not be compatible with other communications technologies or that will be expensive relative to facilities that can be deployed in the near future.

With established suppliers finding it difficult to determine the elements of an appropriate network architecture, new entrants could find it even harder to accurately forecast future market trends and evaluate the comparative advantages of the different technologies. The investment risks in such a dynamic setting are significant and more easily borne by large diversified companies. In addition, the large firm can spread the fixed costs of evaluating new technologies with uncertain results over a large number of units.

In the integrated organisation, network design and planning can be done by consultation between those who sell the product, those who make it, and those who supply large parts or systems for it. Together, they forecast capacity needs and identify product improvements and investments in specialised equipment

which promise higher quality and lower production costs. If the investment is highly specific, vertical integration alleviates the hold-up problem by eliminating the opportunity to negotiate over the price paid to the owner of the newly created asset.³⁹

Under the structural separation approach, who would decide which type of network to provide and how would the risk be spread? With a vertically integrated firm, the risk is internal to the firm. When an incumbent decides to upgrade its network, it decides if it will be upgraded to provide voice and data, or voice, data and video. How would all this be handled by the structurally separated LoopCo? How would this wholesale company focused on wholesale services select the appropriate technologies to meet consumer demands in the dynamic telecommunications market?

Given the high degree of uncertainty and asset specificity which currently characterises the telecommunication industry, it seems that a vertically integrated firm can more easily bear the risks and uncertainty of providing local telecommunications service than a non-integrated firm, and better ensure proper network design.

Without competition in the last mile, incumbents are not under pressure to invest. Proponents of structural separation claim that with a separated LoopCo, operators would be able to develop innovative products without having to approach an integrated operator with which it would be simultaneously a customer and a competitor. Thus, a new entrant's ability to innovate would improve. However, it is possible that the physical, technical and organisational constraints imposed by structural separation could discourage or distract incumbents from designing innovative enhanced services that utilise the resources of the PSTN.

What incentives will be put in place to ensure the necessary investment and innovation to upgrade the local loop?

The ability and incentives for a wholesale operator such as LoopCo to innovate are crucial to the outcome. The nature and extent of these incentives has not been spelt out by proponents of structural separation.

Impact on investment and innovation to upgrade the local loop: In view of the movement that will occur from narrowband circuit switched services to broadband services, the impact on incentives to invest and innovate are crucial. The nature and extent of the impact on such incentives has not been specified in detail in proposals for structural separation.

There are concerns over whether there will be adequate investment in network infrastructure when providers are denied the revenues and consequent incentives that flow from vertical integration. This problem is acute in the telecommunications industry, where technological change is rapid and where investment demands are pressing. Problems of co-ordinating investment between the wholesale and retail operators would also impede investment and innovation. These problems could be considerable and could serve to delay the extension of fibre closer to the customer.

It is not evident that ownership separation would result in greater innovation. Structural separation is likely to have some success in regard to promoting competition and this in turn could promote network enhancement. But some analysts have voiced concerns that structural separation could be detrimental in regard to promoting innovation. They consider that in many OECD countries, the changed stock market sentiment towards telecommunications operators may well mean that it is the incumbents with the benefit of a steady cash flow that could be in the best financial position to enhance the network and the local loop. And structural separation threatens to weaken the ability of incumbents to make such crucial investments.

There is also a considerable one-off cost of divestment, in the form of transaction costs, dislocation costs and risks of interruptions in supply as new lines of command are established.

IMPACT ON COSTS, CONSUMERS AND REGULATION

How will impacts on consumers be addressed?

Structural separation would still require the new entrants to compete for customers. The fact is that even after structural separation occurs, these customers will stay with the incumbent until they are competed away. It is questionable whether structural separation will have much impact since significant commercial obstacles will remain for any new entrant, given the power that the incumbent will have by virtue of its reputation and relationship with customers and the market.

What would happen to the incumbents' customers? The retail company which remains after the incumbent is broken up will naturally want to retain all of its existing customers. How would this advantage be handled in response to demands by new entrant competitors for an allocated share of these customers?

Impact on end-user consumers? The impact on end-user consumers is uncertain. If competition strengthens significantly, it is possible that prices could fall, with innovation and quality of service improving. But there is inadequate evidence to generate confidence that this would necessarily happen. Prices could also rise significantly.

High implementation costs. In addition to the loss of any economies of scope, vertical separation may involve a substantial one-time cost associated with the break-up of the integrated firm. According to one estimate, structurally separating Telstra would cost "hundreds of millions of dollars" amounting to about AUD 1 (USD 0.55) a share.⁴⁰ Such costs are an important part of the cost-benefit trade-off associated with separation.

Pociask⁴¹ identifies various costs resulting from structural separation.

Table 2. Increase in costs due to structural separation

Increased transactions	Duplicate staff
More vendors	Human resources
More contracts	Labour relations
More purchasing agents	Legal
More purchase orders	Regulatory
More spot purchases	Vehicle maintenance
More invoices	Building maintenance
More supplier payments	Administrative services
More billing	Material transport/storage
More regulations	Finance and corporate
More customer calls	Security, information systems

Source: Stephen B. Pociask, "Structural Separation of BellSouth Telecommunications and its Effects on Florida Consumers", *TeleNomic Research*, 31 July 2001, page 11 at www.TeleNomic.com

Pociask estimates that a separated wholesale operator established in Florida would have to raise its wholesale prices by at least 45% in order to maintain a modest rate of return. If these costs are passed along to consumers, Pociask estimates that end-user retail telecommunications prices in Florida would increase by at least 11%.

Structural separation will result in the incumbent incurring new and potentially significant costs that would be passed on to consumers. These costs too must be measured and compared against the anticipated benefits of structural separation. Moreover, price regulation might be necessary to ensure that cost increases do not result in higher prices. If so, this would erode one of the main arguments for structural separation – which is that it promises to reduce regulation.

Product quality. A customer can usually more easily hold a single vertically integrated supplier accountable for some form of product failure. Without this single point of accountability, consumers can find it difficult to find the service department/party responsible for the failure. How will this problem be addressed?

What changes in regulation will be needed?

Structural separation will result in parts of the existing regulatory regime becoming redundant. However, some form of access regime would still be required to govern commercial access to the network. Simply splitting up the wholesale and retail operations of a firm would not necessarily eliminate the market power of the wholesale unit with respect to rival firms. An unregulated wholesale division could charge all retailers (each in effect would be unaffiliated after structural separation) the monopoly price for the input. Thus, it is likely that price regulation will continue to be necessary. But how would such regulation of the structurally separated wholesale supplier result in lower regulated wholesale rates than those set on the basis of forward-looking long-run incremental costs (LRAIC) or “best practice” benchmarking (as occurs in current regulatory procedures)?

A range of other regulatory issues will also need to be resolved. For instance, once LoopCo is operating, will the incumbent be permitted to develop its own network and re-integrate? If so, what will LoopCo be able to do to compete? To what extent will LoopCo be allowed to develop value-added services to maintain and expand its business. How will the pricing and regulatory policy be set up to allow LoopCo to compete? Will vertically integrated new entrants be permitted to set up new loops to compete against LoopCo?

WEIGHING BENEFITS AGAINST COSTS

Are the benefits of structural separation demonstrably in excess of the costs?

Proposals for structural separation should be subjected to a benefit-cost analysis of the specific change being proposed. Box 1 indicates some of the benefits and costs commonly ascribed to structural separation. But, as this paper argues, many of the ascribed benefits do not hold up well to more detailed analysis. This is the case, for example, with the perception that structural separation of the local loop is relatively simple whereas in reality such action raises a number of complex issues which are raised in this paper. Similarly, while structural separation may reduce the need and costs of regulation because behavioural remedies may no longer be necessary, new regulatory issues are raised which will require continued regulatory intervention.

Box 1. Some benefits and costs of structural separation

Benefits	Costs
Benefits of altered incentives towards non-discrimination	High implementation costs
Improves information and restricts cross-subsidisation if LoopCo is restricted from providing services	Irreversible
Reduces anti-competitive activities, leading to increased competition and its benefits	Negative impact on broadband development
Relatively simple (compared to behavioural remedies)	Loss of economies of scale and scope
Management and regulators can focus on the wholesale network	Erosion of incentives to upgrade network
Reduces the need for and cost of regulation	Loss of bundling advantages

It soon becomes clear that even a limited quantitative assessment of structural separation (that ignores secondary benefits and costs) will be difficult. Attempting to identify the benefits and costs of structural separation involves assigning values to many current benefits and costs that are difficult to quantify, as well as projecting them forward into a future in which telecommunications technologies and markets may change in unpredictable ways. It is important to be specific about the time period over which the evaluation is made, especially in view of the rate of technical progress in the telecommunications industry, including access networks. For example, it is expected that there will be significant migration to the use of packet switched networks for the provision of public voice services. The impact of such changes is difficult to assess in terms of future costs and revenue streams for operators.

Clearly, an *a priori* assessment of the benefits of structural separation will depend unavoidably upon judgements/assumptions made on a range of variables, including the competitive constraints now placed on a vertically integrated incumbent (by regulation, by the competing infrastructure and also by other infrastructures deployed in the future).

This paper focuses on the costs and benefits of complete separation of ownership of the competitive network services from the (presumed non-competitive) local loop services because only complete divestiture and separation of ownership can eliminate the wholesale provider's incentive to discriminate. There are less extreme forms of separation such as accounting separation that, while not completely eliminating the incentive to discriminate, may make it easier to detect and punish such discrimination. Arguably, a cost-benefit analysis of structural separation must carefully specify and consider the degree of separation and how that affects both the ability of the regulator to detect discrimination, and the cost of the structural separation. This is not attempted here.

The benefits of structural separation

Benefits of altered incentives. Proponents of structural separation along the lines of a NetCo or LoopCo consider that a major benefit of this measure is that it would reduce the incentive of the owner of the non-competitive component to restrict competition in the competitive component. Some change/realignment in incentives is likely to occur. But the extent and value of these benefits are far from clear and would be difficult to measure and value.

Separation improves information and restricts cross-subsidisation. Vertical separation, by separating the competitive from the non-competitive activities, could help to prevent cross-subsidisation. And it is also likely to be easier to obtain reliable cost information about the non-competitive activity when it is separated into its own distinct ownership as this reduces the opportunities for (and makes more transparent the practice of) using internal transfer prices to shift costs and profits around within the firm.

Greater incentives to modernise and innovate in the local loop for broadband?

As noted earlier, it is not evident that ownership separation would result in greater innovation. Indeed, there are concerns that structural separation could be detrimental in regard to promoting innovation by, for instance, weakening the ability of incumbents to make critical network upgrade investments.

The costs of structural separation

The costs of separation must be weighed against the benefits

Impact on broadband deployment. Potential costs can arise from probable technical changes that would alter network topology. The effect of making a separation at the MDF under existing technologies would divide the fibre (under the new technology) between two owners. Problems of co-ordinating investment between the two parties could be significant. Important innovations in the services offered to final consumers may require investments in the services provided by both the competitive and non-competitive activities. Although, in principle, contractual arrangements could specify the procedures to be followed in the event of certain innovations, in practice the uncertainty in the nature, timing and scope of innovation make such arrangements impractical.

Vertical separation may involve the loss of cost economies from integration. There are various potential sources of these economies of scope. Vertical integration may enhance the availability of information (allowing more efficient incentive contracts); may reduce transaction costs and improve investment in relationship-specific assets by overcoming hold-up problems; and may reduce the distortions associated with market power at one or both of the two levels.⁴²

Because of the heavy additional costs imposed by structural separation and the likely continued regulation of the charges and other terms and conditions of the wholesale services, the wholesale company's incentives to upgrade the network to develop broadband infrastructure could be eroded. Deployment of broadband services would be assisted if the investment community remains convinced that investments in infrastructure can be recovered through the exponentially growing revenues from new Internet-related services.

Separation would result in a loss of economies of scope. The traditional argument in favour of maintaining a variety of economic activities within one very large corporation is that this generates economies of scope and scale through incorporating a wide range of related economic activities within one organisation. A horizontally and vertically integrated incumbent can generate internal synergies that enhance efficiency.

Substantial economies of scope commonly exist in multi-product firms such as telecommunications companies. However, recognising that vertical economies of scope exist is quite different from being able to assess their magnitude in practice.

A vertically integrated telecommunications company may achieve lower cost structures, for instance, by spreading billing costs across a wide range of services. Similarly, it can produce service packages (“bundling”) at a lower cost than a firm producing the same services on a stand-alone basis. Vertical integration enables the firm to co-ordinate production and investment decisions by minimising external transaction processes and their attendant costs and delays. Such a mode of operation is particularly necessary in an industry operating on the ‘technological frontier’, where internal processes and structures need to be highly responsive to change.

Many of these potential sources of cost efficiencies can be at least partially exploited through contractual arrangements between separate firms. Thus, an understanding of the costs of separation requires a comparison between the cost efficiencies achievable under integration and the cost efficiencies achievable through contractual arrangements. To the extent that there are vertical contractual arrangements that can achieve the same efficiency benefits as integration, the economies of scope are accordingly diminished.⁴³ And, of course, any diseconomies of scale and scope should also be recognised.

High implementation costs. In addition to the loss of any economies of scope, vertical separation may involve a substantial one-off cost associated with the break-up of the integrated firm. This cost is a relevant part of the cost-benefit analysis of structural separation.

Structural separation would require the incumbent to incur new and potentially significant costs, and it is likely that these costs would be passed on to consumers. These costs must be measured and compared against the anticipated benefits of structural separation within the telecommunications industry. Further, to ensure that costs do not overly impact on prices, it may be necessary for the incumbent to face further regulation. If this is necessary, it must be asked how this can be justified when one of the main reasons for structural separation is that it creates less regulation, rather than more.

The substantial transaction costs involved in full structural separation could make such a change undesirable. Such costs would extend well beyond the usual costs associated with such major business transactions, to include a variety of consequential costs such as business reorganisation costs in each of the new companies.

Loss of bundling advantages. A structurally separated incumbent will no longer be able to offer a cost-efficient bundled package of services. There is a cost resulting from this. There is a cost also from requiring that the incumbent alone be handicapped by requiring it to offer its services through separate corporate entities. And there is clearly a cost from imposing the substantial extra financial costs and inefficiencies of structural separation in terms of duplication of facilities, personnel and systems on the incumbent alone.

Some estimates of higher expenses and prices. Structural separation could raise costs associated with developing and maintaining duplicated computer systems for ordering, installing and repairing phone service. For instance, Verizon claimed that an estimated one-time cost of over USD 800 million would be incurred to implement full structural separation, with a continuing cost of USD 300 million a year.⁴⁴

Pociask concludes that in the case of the structural separation proposed in Florida, costs exceeded benefits: “From a cost/benefit perspective, using the potential increase in retail rates, this study estimates that total economic costs would increase as much as USD 1.2 billion, including an estimate for *additional costs* of structural separation. Thus, the cost of structural separation exceeds the supposed benefit of local competition (in Florida, estimated to be as high as USD 248 million per year)”⁴⁵

The benefits and costs identified above cannot be quantified and evaluated to provide a clear conclusion as to whether benefits exceed costs. This inconclusiveness raises serious doubts as to whether there is yet sufficient evidence for the structural separation of incumbent carriers to be confidently supported. The costs of structural separation in divestment costs, lost innovation and inefficiency might make this approach far less desirable than non-structural regulatory safeguards. Even though behavioural regulatory constraints would place some restrictions on incumbents' activities, they would largely avoid imposing regulatory limitations on the design and implementation of new services.

What is the policy position of governments/authorities that have considered the use of structural separation?

The policy position adopted by OECD governments/authorities that have considered the use of structural separation is also of considerable interest in assessing this measure.

The United States

In 1999, the Public Utilities Commission (PUC) of the state of Pennsylvania ordered Verizon to structurally separate its retail and wholesale businesses, but the order was subsequently modified (after a state court challenge by Verizon) to require accounting separation only. In March 2001, the PUC acknowledged that the structural separation it had originally supported would involve substantial costs and would require at least as much ongoing regulatory monitoring as the existing access arrangements.

The Pennsylvania Public Service Commission is the only state Commission in the United States that has issued affirmative orders endorsing structural separation. In September 1999, the Commission concluded that: "structural separation is the most efficient tool to ensure local telephone competition where a large incumbent monopoly controls the market". The Commission directed Bell Atlantic-Pennsylvania (Verizon) to submit a plan to formally split into two companies through a complete transfer of assets. Under this structure, one company would focus on retail operations, such as residential service marketing and billing, while the second company would focus on wholesale operations, such as leasing phone lines to the retail company and competitive local exchange carriers (CLECs). However, on 22 March, 2001, the Commission in effect modified its position, presenting Verizon with an offer to accept "functional structural separation", with conditions. Key conditions include:

- A requirement that Verizon functionally separate its wholesale and retail divisions through the application of a Code of Conduct, in a way that provides for non-discriminatory access to its wholesale division by all CLECs.
- A provision for increased penalties if Verizon does not adhere to the order.
- A reservation by the Commission of the right to seek full structural separation if Verizon's behaviour does not improve.

In the United States, the Department of Justice (DOJ) and the FCC have long recognised both the value and limitations of structural separation as a regulatory tool or a remedy for anticompetitive conduct. The DOJ, for example, required AT&T to divest its local telephone operating companies from AT&T's long-distance operations as a condition of settling the government's monopolisation suit against AT&T⁴⁶ (however, it should be noted that this separation resulted in companies which had networks and provided services, unlike the concept of LoopCo which would result in a "pure" infrastructure provider).

In addition, the FCC, as early as 1971, in *Computer I*, and in subsequent proceedings, used various degrees of structural separation to prevent access discrimination and cost misallocation by incumbents in the provision of enhanced services. In *Computer I*, the FCC imposed a “maximum separation policy” on the provision of data processing services by the incumbent.⁴⁷ In 1986, in the *Computer III* proceedings, the FCC gave carriers the option of replacing structural separation with a system of non-structural safeguards. In *Computer III*, the FCC concluded that “structural separation can impose opportunity costs by discouraging the incumbents from designing innovative enhanced services that utilize the resources of the public switched network.”⁴⁸

Similarly, the FCC imposed a lighter form of structural separation on independent incumbent LECs (*i.e.* incumbent LECs that are not Bell Operating Companies – BOCs) that sought to provide interstate, inter-exchange services.⁴⁹ Following the statutory requirements set forth in the Telecommunications Act of 1996, the Commission imposed structural separation on the provision of in-region, inter-LATA services by the BOCs.

The FCC has an open proceeding in which it has sought comment on whether to eliminate the separate affiliate requirements imposed on independent incumbent LECs.⁵⁰ The FCC also has sought comment on what type of regulatory approach is appropriate for BOC provision of in-region inter-LATA services as the statutory three-year separate affiliate requirement expires on a state-by-state basis.⁵¹

The European Union

The European Commission (in the electricity directive 96/92/CE and the gas directive 98/30/CE and elsewhere) has not required structural separation but has relied on access regulation supported by accounting separation.

In Europe, countries which have examined the structural separation option have to date not adopted it. The French authorities have argued that “accounting separation, combined with Chinese walls around the monopoly at the heart of the vertically integrated enterprise offers good assurance of protection against anti-competitive behaviour”.⁵² The Norwegian Parliament voted against a proposal for separation of the Telenor network into a separate company in 1999.⁵³

Awareness of the high administrative and legal costs likely to be associated with such moves probably accounts for some of the doubts about structural separation, but it also reflects scepticism about the actual benefits of such a measure.

United Kingdom

The UK regulator Oftel has rejected the use of structural separation, explaining in an April 2001 report:

“Some commentators have suggested that a means of addressing ... competition concerns is to prevent the creation of vertically integrated companies, and thereby forcibly separate content and carriage markets. In some cases, vertical integration enacted through merger and acquisition may be adjudged to be against the public interest. But Oftel believes an all-encompassing prevention of vertical integration would be unjustified, since it may hamper innovation in new services, damage competition across different platforms and hinder UK firms competing in world markets.

Rather than precluding vertical integration altogether, it is more appropriate to address any competition concerns through action by the sectoral regulator.

The potential problems which might emerge when vertically integrated operators have market power are not new. More importantly, the solutions to such problems are well-established. For instance, BT is subject to obligations relating to the provision of access to its network on non-discriminatory terms. These obligations help prevent market power in one market from being leveraged into another market.⁵⁴

The structural separation issue is still alive in the United Kingdom. In April 2002, a House of Commons Committee report referring to proposals for structural separation of dominant vertically integrated telecommunications operators recommended that Oftel (or its successor OFCOM) “take account” of such propositions.⁵⁵

Japan

In February 2002, the Japanese Ministry of Public Management, Home Affairs, Posts and Telecommunications (MPHPT) received recommendations relating to Japanese telecommunications policy from an expert group called the Telecommunications Council. The Council considered the merits and demerits of structural separation⁵⁶ and observed: “fair access to the network and the firewall between monopolistic operation and competitive operation would be achieved more thoroughly by structural separation” and “conflicts of interests between the wholesale sector and the retail sector would be resolved and smooth opening of the network would be easier to do”. As the Council observed: “There are no actual cases in other countries, and it is hard to generate confidence that a smooth implementation is possible”.⁵⁷ Moreover, “the monopolistic status of bottleneck facilities will not change before or after structural separation”.⁵⁸ The last Council report in August 2002 concluded that: “With regard to promotion of competition policy through structural separation, further careful discussion would be necessary, including consideration of the merits and demerits of the approach and of the situation in consideration in foreign countries, etc.”.

Australia

In Australia, the issue of structural separation was to have been considered by a parliamentary committee established in November 2002,⁵⁹ but this parliamentary inquiry was abandoned when the opposition Labor Party announced it would no longer consider structural separation of Telstra as a policy option because it was too costly and too complex.⁶⁰ The Australian government has announced that the use of accounting separation – in place since 1997 – is to be strengthened. Telstra, the dominant incumbent, is to be required to publish current and historical cost statements in respect of “core” interconnect services and to compare its actual performance in supplying core services to itself and to external access seekers.

CONCLUSION

Vertical separation is a significant intervention in the marketplace, with substantial and – unlike behavioural regulation which can be reversed – irreversible costs. It should not be undertaken lightly. Seemingly simple in concept, structural separation of the local loop is in practice complex with uncertain outcomes and many questions to be answered. The benefits of structural separation of the local loop are uncertain while the costs are certain and appear potentially large. There is little evidence that the benefits of structural separation of the local loop are sufficiently in excess of costs. Accordingly, it would seem more sensible to persevere with the current regulatory approach (with appropriate improvements and augmented by sanctions). Only if regulatory authorities can show that the benefits are in excess of the costs, and that alternative regulatory approaches would not work, should consideration be given to the structural separation of the local loop.

NOTES

- ¹ See OECD, *Communications Outlook 2003*, Paris 2003.
- ² The local loop refers to the physical circuit between the customer's premises and the telecommunications operator's local switch or equivalent facility. Traditionally it takes the form of pairs of copper wires (one pair per normal telephone line), but increasingly fibre optic cables are being deployed to connect large customers, and other technologies are also being rolled out in the local access network. However, the deployment of optical fibre is not an economically viable alternative for small and medium-sized enterprises (SMEs) and residential customers. The incumbent's copper pair is the key infrastructure for providing: *i*) access voice telephony retail services, which includes call termination; *ii*) local call (origination) services; and *iii*) high-bandwidth services to end-users.
- ³ These advantages include: bottleneck control of the local loop; vertical integration allowing the leverage of monopoly in some areas to support other areas; opportunity for "cross-market" leverage from strength in traditional markets into adjacent markets; network effects where customers benefit from being connected to larger networks; historical "first-mover" advantages; economies of scale; high economies of density; sunk costs (which allow the incumbent scope to restrict entry by cutting prices to very low avoidable costs).
- ⁴ This results from the fact that the incumbent rolled out its local access networks over significant periods of time protected by exclusive rights and was able to fund its investment costs through monopoly rents. In addition, the ubiquity of the copper local loop access infrastructure controlled by the incumbent operator is not in all circumstances economically feasible to duplicate, and alternative local access infrastructures (cable-TV, wireless local loops, satellite, etc.) cannot usually be constructed with the same ubiquity and competitive conditions within a reasonable time.
- ⁵ The growing concerns about investment in the local loop are reflected, for instance, in the European Commission's 2002 framework directive, wherein National Regulatory Authorities (NRAs) duties are specifically to include "encouraging efficient investment in infrastructure, and promoting innovation".
- ⁶ "The slow progress of fast wires", *The Economist*, 15 February 2001. In November 2001, the EC called on all 15 European Union member states to make greater efforts to enforce LLU requirements. Laura Rohde, "Study warns local loop unbundling failing in Europe", Itworld.com, 2/11/02.
- ⁷ David Gabel, "Why is there so little competition in the provision of local telecommunications services? An examination of alternative approaches to end-user access," Department of Economics, Queen's College, 21 August 2002.
- ⁸ Roy L. Morris, "A Proposal to Promote Telephone Competition: The LoopCo Plan," 2001 available at http://members.aol.com/_ht_a/RoyM11/LoopCo/Article.html; Gerd Eickers, *Local Loop Unbundling in Germany: The Broadband Perspective*, mimeo 2001.
- ⁹ For instance, in the United States, in the Modification of Final Judgment which settled the government's antitrust suit against AT&T, AT&T agreed to divest its local operating companies from its long-distance business.

- 10 The FCC initially imposed “maximum [structural] separation” but later because of the costs of this stringent separation, gave the carriers subject to this requirement the choice of offering enhanced services through a separate subsidiary or complying with strict non-structural safeguards.
- 11 *Structural Separation in Regulated Industries*, report by the Secretariat? DAFFE/CLP(2001)11, OECD, 11 April 2001.
- 12 Suffice to say here that this is a desirable separation to ensure that the ability of cable to provide competition based on an alternative infrastructure is not foreclosed.
- 13 In May 2002, the telecommunications spokesman for the Australian Labour Party (the present opposition party in the Australian Federal Parliament) placed wholesale-retail structural separation on the political agenda by saying that this approach should be one of the options considered in a much-needed review of Australian telecommunications policy.
- 14 A LoopCo approach has been proposed, for example, by Cable & Wireless in the United Kingdom and by AT&T in the United States.
- 15 R W Crandall and J G Sidak, “Is Structural Separation of Incumbent local Exchange Carriers Necessary for Competition?” *Yale Journal on Regulation*, Vol. 19, No. 2, 2002.
- 16 Martin Cave, “Is LoopCo the answer?”, *Info*, Vol. 4, No. 4, 2003. pp. 25-31.
- 17 David Gabel, *op. cit.* See also Adam Thierer and Clyde Wayne Crews, “Structural Separation of the Bells – An idea whose time has passed”, *TechKnowledge*, Cato Institute, Issue 17, August 20, 2001, available at <http://www.cato.org/cgi-bin/scripts/printtech.cgi/tech/tk/010820-tk.html>.
- 18 Where possible consideration should be given to the re-distributional impacts of structural separation, *i.e.* who benefits and who bears the costs in the short and long term.
- 19 Recommendation of the Council Concerning Structural Regulation in Regulated Industries, reprinted in *Restructuring Public Utilities for Competition*, Policy Brief, OECD Observer, Feb 2002.
- 20 The LoopCo proposal is discussed in some detail in Roy L. Morris, “A Proposal to Promote Telephone Competition: The LoopCo Plan”, 2001 available at: http://members.aol.com/_ht_a/RoyM11/LoopCo/Article.html; Martin Cave, “Is LoopCo the answer?”, *Info* Volume 4, Number 4, 2003. pp. 25-31; and J Sandbach, “Levering open the local loop: shaping BT for competition”, *Info*, Vol. 3, No. 3, pp 195-202, 2001.
- 21 The likely development of more fibre deployed in the local loop is to take the unduplicated asset (fibre) more deeply into the core network, beyond the MDF. This could create co-ordination problems. There will be a changing topology of the network, changes on the other side of the MDF as currently located, and the MDF as it is currently is likely to disappear in an optimally designed network. But with LoopCo it - or something equivalent - will remain as it is the demarcation point. The implication is that, if LoopCo were created, these developments would require the co-ordination of investments between LoopCo and a network operator, as well as joint operation of the fibre assets. Investment decisions would require a common view of future revenue streams between a wholesale operator and a network operator that may also be a retailer, which will prove very hard to achieve. There is then a serious risk that a separation based on existing technology would hamper future developments²¹. This is a major and potentially durable cost of separation, and one that it is difficult to quantify.
- 22 For a critical review see R. Crandall and J.G. Sidak, “Is Structural Separation of Incumbent Local Exchange Carriers Necessary for Competition?” *Yale Journal on Regulation*, 2002.

- 23 Speech by Michael Armstrong to the National Press Club, 7 Feb 2001 at:
<http://www.att.com/speeches/item/0,1363,3662,00.html>.
- 24 BT, "Statement of Sir Peter Bonfield, CEO of BT", News Release 0087, 9 November 2000.
- 25 For a critique of the UK proposal, see R. Crandall and J.G. Sidak, "Is Structural Separation of Incumbent Local Exchange Carriers Necessary for Competition?" *Yale Journal on Regulation*, 2002; Jonathan Sandbach, "Levering open the local loop: shaping BT for broadband competition", *Info*, Vol 3, No. 3, June 2001, p.200. For a critique of the Australian proposal, see Ros Eason, "What role for Telstra", Evatt Foundation, July 2002, available at <http://evatt.labor.net.au>. Eason argues that a NetCo approach would create inefficiencies and would retard innovation and investment in this critical sector of the economy.
- 26 T. Randolph Beard, George S. Ford, and Lawrence J. Spiwak. "Why ADco? Why Now? An Economic Exploration into the Future of Industry Structure for the 'Last Mile' in Local Telecommunications Markets", The Phoenix Center for Advanced Legal and Economic Public Policy Studies, Phoenix Center Policy Paper No. 12, November 2001, Washington, DC.
- 27 T. Randolph Beard, George S. Ford, and Lawrence J. Spiwak, *Op. cit.*
- 28 *Structural Separation in Regulated Industries*, report by the Secretariat DAFPE/CLP(2001)11, OECD, 11 April 2001.
- 29 Petition of Rochester Telephone Corporation for Approval of Proposed Restructuring Plan, Petition of Rochester Telephone Corporation for Approval of a New Multi Year Stability Agreement, Case 93-C-0103, N.Y. Pub.Serv. Comm'n, Nov. 10, 1994, 1994 N.Y. PUC LEXIS 64, *3.
- 30 Cited in Crandall and Sidak, *Op. cit.*, p. 47.
- 31 Crandall and Sidak, *Op. cit.*, p. 47.
- 32 BT, "Statement of Sir Peter Bonfield, CEO of BT", News Release 0087, 9 November 2000.
- 33 Crandall and Sidak, *Op. cit.*
- 34 For example, Crandall and Sidak, *Op. cit.*
- 35 This discussion draws on David Gabel, *Op.cit.*
- 36 These economies of scale exist because of the high capital and construction costs that require at least a minimum scale, and, furthermore, are an additional barrier to entry because the fixed costs are also sunk once the facilities are built.
- 37 The following discussion and illustrations on the need for investment in the local loop draw on Jeffrey Eisenach, "Regulatory Overkill: Pennsylvania's Proposal to Breakup Bell Atlantic", available at <http://www.ppf.org/papucreport.htm>
- 38 For instance, Telstra's CEO stated Telstra's argument as follows: "[T]hey know that breaking up Telstra could cost billions of dollars. Telecommunications networks are not like gas, electricity or water. They are interconnected computer systems that are highly complex, integrated and constantly changing. It would be easier to divide a spider's web than separate Telstra's retail and wholesale intercarrier layers" (Dr. Ziggy Switkowski, "Telstra Just Too Good", *Herald Sun Newspaper*, 23 May 2002).
- 39 A more detailed discussion is available in Crandall and Sidak, *Op. cit.*, page 35.

- 40 “Telstra split costs millions”, *The Courier-Mail*, 25 September 2002.
- 41 Stephen B. Pociask, “Structural Separation of BellSouth Telecommunications and its Effects on Florida Consumers”, eleNomic Research, 31 July 2001, at www.TeleNomic.com. This paper has been written by a consultant to a vertically integrated US incumbent operator.
- 42 *Structural Separation in Regulated Industries*, report by the Secretariat, DAFFE/CLP(2001)11, OECD, 11 April 2001.
- 43 OECD, Op. cit.
- 44 In Docket No. M-00001353 before the Pennsylvania Commission. It should be noted that Verizon is a vertically integrated operator.
- 45 Stephen B. Pociask, “Competition and Consumer Benefits: A Quantitative Assessment of the In-region Bell South Long-Distance Market”, *TeleNomic Research*, Herndon, VA, 29 May 2001, p. 17.
- 46 *United States v. WesternElectric Co* 552F.Supp.131 (D.D.C. 1982), *aff’d sub nom. Maryland v. United States*, 460 U.S. 1001 (1938).
- 47 *United States v. WesternElectric Co* 552F.Supp.131 (D.D.C. 1982), *aff’d sub nom. Maryland v. United States*, 460 U.S. 1001 (1938).
- 48 *Amendment of Section 64.702 of the Commission’s Rules and Regulations (Computer III)*, Report and Order, CC Docket No. 85-229, Phase I, 104 FCC 2d 958 (1986).
- 49 See *Regulatory Treatment of LEC Provision of Interexchange Services Originating in the LEC’s Local Exchange Area*, 12 FCC Rcd 15756 (1997).
- 50 See 2000 Biennial Regulatory Review: Separate Affiliate Requirements of Section 64.1903 of the Commission’s Rules, CC Docket No. 00-175, Notice of Proposed Rulemaking, 16 FCC Rcd 17270 (2001).
- 51 See Section 272(f)(1) Sunset of the BOC Separate Affiliate and Related Requirements, WC Docket No. 02-112, Notice of Proposed Rulemaking, 17 FCC Rcd 9916 (2002), Memorandum Opinion and Order, 17 FCC Rcd 26869 (2002).
- 52 Cited in OECD, *Structural Separation in Regulated Industries*, Report by the Secretariat DAFFE/CLP (2001) 11, OECD, 11 April 2001.
- 53 OECD, Op cit.
- 54 Oftel, “Open Access: Delivering Effective Competition in Communications Markets,” April 2001, available at <http://www.oftel.gov.uk>
- 55 The Select Committee on Culture, Media & Sport’s report can be found at <http://www.publications.parliament.uk/pa/cm200102/cmselect/cmcmds/539/53902.htm>.
- 56 See “Panel Threatens NTT with Split Up”, *Japan Times Online*, 13 December, 2001 (downloadable from <http://www.japantimes.co.jp/cgi-bin/getarticle.pl5?nb20011213a7.htm> on 5 April, 2002).
- 57 Telecommunications Council, Second Report on Desirable Pro-competitive Policies in the Telecommunications Business Field for Promoting the IT Revolution (Inquiry No. 29 of 2000) (13 May 2002), prepared for MPHPT.

58 Second Report, *Op. cit.*

59 In May 2002, the telecommunications spokesman for the Australian Labour Party (the present opposition party in the Australian Federal Parliament) placed wholesale-retail structural separation on the political agenda by saying that this approach should be one of the options considered in a much needed review of Australian telecommunications policy. See Lindsay Tanner MP, Shadow Minister for Communications, “*Reforming Telstra*,” May 2002. In November 2002, the Australian Parliament’s House of Representatives Standing Committee on Communications, Information Technology and the Arts announced an inquiry into the structural separation of Telstra’s core network from its other businesses but the committee has been disbanded. Submissions made to the parliamentary committee before it was disbanded may be accessed at <http://www.apk.gov.au/house/committee/cita/telstra/index.htm>.

60 “Telstra split rejected by Labor Party”, telecomasia.net, 6 February 2003.