

OECD GUIDELINE FOR THE TESTING OF CHEMICALS

DRAFT PROPOSAL FOR A NEW GUIDELINE: 436

Acute Inhalation Toxicity - Acute Toxic Class (ATC) Method

INTRODUCTION

1. OECD Guidelines are periodically reviewed in the light of scientific progress and animal welfare considerations. The original acute inhalation Test Guideline 403 (1) was adopted in 1981. Development of an Inhalation Acute Toxic Class (ATC) method (2)(3)(4) was considered appropriate following the adoption of the revised oral ATC method (TG 423)(5)(6)(7)(8)(9) in December 2001. This ATC method guideline will allow the use of a series of fixed concentrations for the determination of acute inhalation toxicity in both sexes.

2. Traditional methods for assessing acute toxicity use death of the tested animals as the intended endpoint. This guideline avoid using death of animals as an exclusive endpoint by incorporating evident clinical signs of toxicity at one of a series of fixed dose levels, as an endpoint on which to base classification of the test material. In agreement with the OECD Guidance Document on Humane Endpoints (10) refinements are introduced in order to minimise any suffering and distress by the animals. The oral ATC method (5) uses 3 animals of one sex per step, while the inhalation ATC method utilises 3 animals of each sex at the commencement of testing, which is based on the specific requirements for inhalation toxicity testing (11). Test Guideline 403 normally requires 10 animals for the limit test and 40-50 for the main test, whereas this guideline uses considerably fewer animals. The inhalation ATC method is solely based on biometric evaluations using fixed doses.

3. Guidance on the conduct and interpretation of the Inhalation ATC can be found in the Guidance Document on Acute Inhalation Toxicity Testing (12).

4. The inhalation ATC method provides information both for hazard assessment and for hazard classification purposes. The method provides information on the hazardous properties and allows the substance to be ranked and classified according to the United Nations (UN) Globally Harmonized System of Classification and Labelling of Chemicals (GHS) for the classification of chemicals which cause acute toxicity (13).

5. Definitions used in the context of this Guideline are set out in Annex 1.

INITIAL CONSIDERATIONS

6. All available information on the test substance should be considered by the testing laboratory prior to conducting the study. Such information will include the identity and chemical structure of the substance; its physico-chemical properties; the results of any other *in vitro* or *in vivo* toxicity tests on the substance; available (Q)SAR data and toxicological data on structurally related substances; the anticipated use(s) of the substance and the potential for human exposure. This information will assist in the selection of an appropriate starting concentration.

7. Test substances that are known to cause marked pain and distress due to corrosive or severely irritant actions should not be tested. Moribund animals, or animals obviously in pain or showing signs of severe and enduring distress shall be humanely killed, and are considered in the interpretation of the test

results in the same way as animals that died on test. Criteria for making the decision to kill moribund or severely suffering animals, and guidance on the recognition of predictable or impending death, are the subject of a separate Guidance Document (10).

PRINCIPLE OF THE TEST

8. It is the principle of the test that, based on a stepwise procedure, sufficient information is obtained on the acute toxicity of the test substance to enable its classification. At any of the defined concentrations two steps consisting of 3 animals of one sex per step are tested simultaneously. If evidence is provided that one gender is more susceptible than the other, the test may be continued with the most susceptible gender. Absence or presence of compound-related mortality of the animals exposed at one step will determine the next step, *i.e.*;

- a. no further testing is needed,
- b. testing of the most susceptible gender only,
- c. testing of three male and three female additional animals at the next higher or the next lower concentration level.

9. When there are indications that the test material is likely to be non-toxic a limit test may be performed. Testing in GHS Category 5 is discouraged, but may under certain circumstances be performed (Annex 2).

DESCRIPTION OF THE METHOD

Selection of animal species

10. The preferred species is the rat, although other rodent species may be used. Healthy young adult animals of commonly used laboratory strains should be employed. Females should be nulliparous and non-pregnant. Each animal, at the commencement of testing, should be between 8 and 12 weeks old and its weight should fall within an interval of $\pm 20\%$ of the average body weight recorded at the laboratory for the particular strain used.

Housing and feeding conditions

11. The temperature of the experimental animal maintenance room should be $22 \pm 3^\circ\text{C}$. The relative humidity should be at least 30% and preferably not exceed 70% other than during room cleaning. Animals may be single or group-caged by sex and exposure concentration, but the number of animals per cage should not interfere with clear observations of each animal. Lighting should be artificial, the sequence being 12 hours light, 12 hours dark. For feeding, conventional laboratory diets may be used with an unlimited supply of municipality drinking water.

Preparation of animals

12. The animals are randomly selected, marked for individual identification, and kept in their cages for at least 5 days prior to the start of the test to allow for acclimatisation to the laboratory conditions.

Mode of exposure

13. For acute inhalation toxicity studies the preferred mode of exposure is the head/nose-only exposure technique. This type of exposure minimises exposure or uptake by non-inhalation routes. Additionally, it allows testing of high concentrations as required to meet the limit concentration. The instability of test

compounds (*e.g.*, reactivity with excreta or humidity) and the possible heterogeneity of the test atmosphere in inhalation chambers is of less concern when head/nose-only inhalation chambers are used. The duration required to attain the inhalation chamber equilibration is minimal in head/nose-only chambers. However, the test performer has the option of using other systems (*e.g.*, whole-body inhalation chambers) when justification can be made. Principles of the head-nose only and whole body exposure techniques and their particular advantages and disadvantages have been published elsewhere (14).

Nose-only exposure technique

14. During exposure, the animals are exposed to the test compound in exposure tubes. The animal restraining tubes should not impose undue stress or hyperthermia on the animal. To provide optimal exposure of animals a slight positive balance of air volumes supplied into and extracted from the chamber should be ensured. The design of the restraining tube as well as the flow dynamics should make it impossible for the subject to avoid inhalation exposure. The inhalation chamber should be operated in well ventilated chemical hoods. Maintenance of slight negative pressure inside the hood will prevent leakage of the test substance into the surrounding areas. The animals should be tested with inhalation equipment designed to sustain a dynamic air flow of at least 0.5 L/min/rat. An oxygen content of at least 19% and identical exposure conditions at each exposure port should be ensured. During the sampling of test atmosphere, a significant disturbance of the airflow dynamics should be avoided.

Whole-body exposure technique

15. The animals should be tested with inhalation equipment designed to sustain a dynamic air flow of at least 12 to 15 air changes per hour. Other air flow rate may be useful to meet specific requirements imposed by the test compound. However, an adequate oxygen content of at least 19% and an evenly distributed exposure atmosphere should be ensured. The chamber design should minimise crowding of the test animals and maximise their exposure to the test substance. As a general rule to ensure stability of a chamber atmosphere, the total "volume" of the test animals should not exceed 5% of the volume of the test chamber. Maintenance of slight negative pressure inside the chamber will prevent leakage of the test substance into the surrounding areas.

Monitoring the test atmosphere

16. Assessments concerning possible sampling artefacts, collection efficiency, stability and recovery of the test material sampled should be made. The collection efficiency depends markedly on the physical form of the test agent (vapour, aerosol, particle size) and precautions have to be taken to minimise size-selective sampling errors and that actual concentrations include all physical forms of the substance tested. Ideally, for all instruments/devices used for the quantitative characterisation of exposure atmospheres the respective 'actual concentration' should be reported. Real-time monitoring devices may be used to demonstrate and document that an at least 4-hour equilibrium concentration has been attained and that deviations did not occur during the course of the exposure period.

Exposure conditions

Particle-size distribution

17. The particle-size distribution of the particulate test substances should allow exposure of all relevant regions of the respiratory tract. Particle-size also influences deposition site in the respiratory tract. Since damage and/or deposition to any region of the respiratory tract can induce lethality, and it is not possible to predict, *a priori*, the most responsive region of the tract or the most harmful particle-size range that deposits throughout the entire rodent respiratory tract. An aerosol bracketing a particle-size mass

distribution of mass median aerodynamic diameter (MMAD) 1 to 4 μm and a geometric standard deviation (GSD) in the range of 1.5 to 3.0 therefore appear to be appropriate (14).

Preparation of concentrations

18. A vehicle can be used to help generate an appropriate concentration and particle size of the test substance in the atmosphere. As a rule, water should be given preference.

Control animals

19. A concurrent control group is not necessary. Where a vehicle is used to help generate the test atmosphere, a control group should only be used when historical data are not available.

MONITORING OF EXPOSURE CONDITIONS

Chamber airflow

20. The flow of air through the exposure chambers should be monitored continuously and recorded at least three times during each exposure.

Chamber temperature

21. The temperature at which the test is performed should be maintained at $22 \pm 3^\circ\text{C}$. Ideally, the relative humidity should be maintained between 40 to 60 percent, but in certain instances (*e.g.*, tests on aqueous aerosols) this may not be practicable. Temperature and humidity in the inhalation chamber should be monitored in intervals of at least 30 min. The consistency of the concentration of the compound in the test atmosphere should be monitored at regular intervals. Ideally, a monitoring device may be used to demonstrate that stable exposure conditions prevailed and that the time required to reach the inhalation chamber equilibrium concentration is negligible or is adequately compensated for. It should be noticed that the monitoring of the test atmosphere is an integral measurement of all dynamic parameters and hence provides an indirect means to control all relevant, dynamic inhalation parameters. Specific instruments may not be suitably used when their sensing units get covered with excessive quantities of test material or they are destroyed by the test material. Therefore, for high concentrations of particulate materials, an assessment should be made whether the monitoring of physical chamber parameters generate relevant data.

Relative humidity

22. The relative humidity (RH) in the animal's breathing zone, for both the head/nose only and the whole body exposures, should be monitored continuously and recorded three times during each exposure where possible. The RH should ideally be maintained in the range of 30 to 70% but it is recognised that under certain circumstances this may either be unattainable (*e.g.*, when testing water based formulations) or may not be measurable due to interference by the test substance with the test method.

Concentration of test substance

23. Actual concentrations of the test substance should be measured in the breathing zone of the rats in both the head/nose only and the whole body exposures. During the exposure period, the actual concentrations of the test substance shall be held as constant as practicable and monitored continuously or intermittently depending on the method of analysis. If intermittent sampling is used at least five samples should be taken at approximately hourly intervals. For single component powder aerosols and liquids that

are of extremely low volatility, gravimetric analysis is acceptable. When performing gravimetric sampling at the higher exposure concentrations used in these studies, care should be taken to calibrate the flow meter (or dry gas meter) used to determine sampled volume as a function of the pressure drop across the filter (based upon the relationship pressure x volume = constant). A calibration volume curve should be generated for each flow meter or dry gas meter used.

24. For aerosols of liquid formulations that can be evaporated to a constant weight, gravimetric analysis of the dried residue may be used. Appropriate extrapolation to calculate the weight of formulation should be applied to the gravimetric data. It is not necessary to analyse inert ingredients provided the mixture at the animal's breathing zone is analogous to the formulation; the grounds for this conclusion should be provided in the study report. If there is some difficulty in measuring chamber analytical concentration due to precipitation, non-homogenous mixtures, volatile components, or other factors, additional analyses of inert components may be necessary.

25. Where gravimetric analysis is unsuitable and the test atmosphere contains more than one component, chemical analysis of the major active ingredient followed by extrapolation to the concentration of formulation may be acceptable but should be justified.

26. Whenever the test substance is a formulation, the analytical concentration should be reported for the total formulation and not just for the active ingredient.

27. Assessments concerning possible sampling artefacts, collection efficiency, stability and recovery of the test material sampled should be made. The collection efficiency depends markedly on the physical form of the test agent (vapour, aerosol, particle size) and precautions have to be taken to minimise size-selective sampling errors and that actual concentrations include all physical forms of the substance tested. Ideally, for all instruments/devices used for the quantitative characterisation of exposure atmospheres the respective 'actual concentration' should be reported. Real-time monitoring devices may be used to demonstrate and document that an at least 4-hour equilibrium concentration has been attained and that deviations did not occur during the course of the exposure period.

Particle size distribution

28. The particle size distribution of the test aerosol should be determined at least twice during each 4-hour exposure. A range of sampling devices is suitable but the device selected should allow calculation of the MMAD. In the case of multi-component aerosols the principles given above for determination of concentration should be applied. Adequate information should be available within the testing facility to demonstrate that such samplers collect an atmospheric sample that is representative of the atmosphere to which the animals are exposed.

Nominal concentration

29. The nominal exposure chamber or exposure tube concentration should be determined by recording the amount of test material disseminated into the exposure chamber/tube during the generation period and dividing this by the total airflow through the chamber/tube during the same period.

MAIN STUDY

30. In principle, the method is not intended to allow the calculation of a precise LC₅₀ value, but does allow for the determination of defined exposure ranges where lethality is expected since death of a proportion of the animals is still the most robust experimental endpoint of this test. The method allows for the determination of an LC₅₀ value only when at least two concentrations result in mortality higher than 0%

and lower than 100%. The test can readily be adopted to meet the objective to determine a more precise LC₅₀ value. The use of a selection of pre-defined concentrations, regardless of test substance, with classification explicitly tied to number of animals observed in different states aims at the opportunity for laboratory to laboratory reporting consistency and repeatability. Substances difficult to aerosolise specific considerations may apply.

Number of animals and concentration levels

31. Three animals of each sex are used for each step and two steps are used per concentration. Based on technical characteristics for inhalation toxicity testing the inhalation ATC method consists of testing at one concentration three male and female animals simultaneously. However, it has to take into account the number of dead/moribund animals of each sex separately or of the sum of both genders. Although a probit model with equal LC₅₀ and β -values for both genders is assumed in the calculations, the allocation procedure of a substance is predominantly determined by the mortality of the more sensitive sex. The concentration level to be used as the starting concentration is selected from one of four fixed levels, as shown in Annex 3-5. The starting concentration level should be that which is most likely to produce mortality in some of the exposed animals.

32. The testing schemes included represent the testing with the cut-off values of the GHS for gases (100, 500, 2500, 5000 ppm)(Annex 3), for vapours (0.5, 2, 10, 20 mg/L/4 h) (Annex 4) and for dusts and mists (0.05, 0.5, 1, 5 mg/L/4 h)(Annex 5). For each starting concentration, the respective testing schemes as included in annex 3-5 outline the procedure to be followed. Depending on the number of humanely killed or dead animals, the test procedure follows the indicated arrows.

33. For selecting the starting concentration, all available information should be used, including information on structure-activity relationships (see paragraph 6). When the information suggests that mortality is unlikely at the highest level, then a limit test should be conducted. When there is no information on a substance to be tested, for animal welfare reasons it is recommended to use one of the two medium starting concentrations.

34. The time interval between treatment groups is determined by the onset, duration, and severity of toxic signs. Ideally, treatment of animals at the next concentration should be delayed until confidence of survival of the previously treated animals. However, due to the dependence on sophisticated technologies this may not always be practical in inhalation studies. Therefore, exposure of animals at the next step should be based on previous experience and scientific judgement.

Limit test

35. The limit test is primarily used in situations where the experimenter has information indicating that the test material is likely to be non-toxic, *i.e.*, having toxicity only above regulatory limit doses. Information about the toxicity of the test material can be gained from knowledge about similar tested compounds or similar tested mixtures or products, taking into consideration the identity and percentage of components known to be of toxicological significance. In those situations where there is little or no information about its toxicity, or in which the test material is expected to be toxic, the main test should be performed.

36. Using the normal procedure, a starting concentration of 20 mg/L, 5mg/L or 5000 ppm for vapours, dusts/mists and gases, respectively, followed by exposure of six animals (three animals of each sex) at this level serves as a limit test for this guideline. In some cases, as required by some regulatory authorities, testing up to the limit of GHS class 5 may be conducted. However, testing in animals in Category 5 ranges

is discouraged and should only be considered when there is a strong likelihood that the results of such testing would have a direct relevance to the protection of human health (13)(Annex 2).

37. If compound related mortality is produced, further testing at the next lower concentration level may need to be carried out.

38. When at the limit concentration, one animal per sex dies, the LC₅₀ value is expected to exceed the indicated concentration. However, because this is a “borderline” result, the response of the remaining animals should be carefully considered and the occurrence of evident signs of toxicity in these animals may lead to classification corresponding to an LC₅₀ value of the indicated value or less or would justify further testing at this same level.

39. Generation of respirable aerosols at concentrations exceeding 2 mg/L is experimentally demanding and sometimes technically impossible (16). When a substance is tested at the highest concentration, that is technically possible, and no deaths occur there is no need for further testing.

Administration of concentrations

40. Animals are exposed to the test substance as aerosol, vapour or the mixture thereof. The exposure conditions may depend on either the physico-chemical characteristic of the test substance, the selected concentration or the physical form most likely present during the handling and use of the substance.

41. Feed and water during the exposure period should be withheld.

Observations

42. During the exposure period the animals should be observed frequently. In addition, after exposure, careful clinical observations should be made at least twice on the day of exposure, or more frequently, when indicated by the response of the animals to the treatment, and at least once daily thereafter, for a total of 14 days, except where they are found dead. However, the duration of observation is not fixed but should be determined by the nature and time of onset of clinical signs and length of the recovery period. The times at which signs of toxicity appear and disappear are important, especially if there is a tendency for signs of toxicity to be delayed. All observations are systematically recorded, with individual records being maintained for each animal. Animals found in a moribund condition and animals showing severe pain and/or enduring signs of severe distress should be humanely killed without delay. When animals are killed for humane reasons or found dead, the time of death should be recorded as precisely as possible.

43. A careful clinical examination should be made at least twice on the day of exposure and once per day thereafter. Animals found in a moribund condition and animals showing severe pain or enduring signs of severe distress should be humanely killed for animal welfare reasons. Care should be taken (*e.g.*, by using control animals exposed to air) when conducting examinations for clinical signs of toxicity that initial poor appearance and transient respiratory changes, resulting from the exposure procedure, are not mistaken for treatment-related effects. Additional observations may be necessary during the first few days after dosing so that the test may be terminated if it becomes apparent that the initial dose level chosen was too high. Cage-side observations should include changes in the skin and fur, eyes and mucous membranes, and also respiratory, circulatory, autonomic and central nervous systems, and somatomotor activity and behaviour pattern. Attention should be directed to observations of tremors, convulsions, salivation, diarrhoea, lethargy, sleep and coma. The measurement of rectal temperatures may provide supportive evidence that restraint did not cause undue conditions to the animal. When animals are killed for humane reasons or found dead, the time of death should be recorded as precisely as possible.

Body weights

44. Individual weights of animals should be determined shortly before the test substance is administered (day 0), day 3 and 7, weekly thereafter and at death. Weight changes should be calculated and recorded. At the end of the test surviving animals are weighed and humanely killed.

Pathology

45. All test animals (including those which die during the test or are removed from the study for animal welfare reasons) should be subjected to gross necropsy. All gross pathological changes should be recorded for each animal with particular reference to any changes in the respiratory tract. Microscopic examination of organs showing evidence of gross pathology in animals surviving 24 or more hours may also be considered because it may yield useful information.

DATA AND REPORTING

Data

46. Individual animal data on body weights and necropsy findings should be provided. Clinical observation data should be summarised in tabular form, showing for each test group the number of animals used, the number of animals displaying (specific) signs of toxicity, the number of animals found dead during the test or killed for humane reasons, time of death of individual animals, a description and the time course of toxic effects and reversibility, and necropsy findings.

Test report

47. The test report should include the following information, as appropriate:

Test substance

- physical nature, purity, and, where relevant, physico-chemical properties (including isomerisation);
- identification data and Chemical Abstract Services Registry Number, if known.

Vehicle

- justification for use of vehicle and justification for choice of vehicle (if other than water).
- historical or concurrent data demonstrating that the vehicle does not interfere with the outcome of the study.

Inhalation chamber

- Source and description of equipment used for the exposure of animals as well as generation of atmosphere
- Equipment for measuring temperature, humidity, particle-size, and actual concentration
- Source of air, system used for conditioning
- Methods used for calibration of equipment to ensure a homogeneous test atmosphere
- Dimensions and volumes of inhalation chambers
- Pressure difference (positive or negative)
- Exposure ports per chamber (nose-only), location of animals in the chamber (whole-body)
- Temporal homogeneity/stability of test atmosphere
- Location of temperature and humidity sensors and sampling of test atmosphere in the chamber.
- Treatment of air supplied/extracted

- Air flow rates, air flow rate/exposure port (nose-only) or animal load/chamber (whole-body)
- time required to reach inhalation equilibrium, t_{90} or t_{99} ($k \times$ chamber volume/flow; for t_{90} , $k = 2.303$, and t_{99} , $k = 4.605$)
- Number of volume changes per hour
- Metering devices (if applicable)

Exposure data

- nominal concentrations (total amount of test substance supplied into the inhalation equipment divided by volume of air used for atmosphere generation)
- actual concentrations collected from the breathing zone of animals; for test mixtures produces heterogeneous physical forms (vapours, aerosols) each may be analysed separately.
- particle size distribution (*e.g.*, mass median aerodynamic diameter, MMAD, and geometric standard deviation, GSD), including their methods of calculation. Individual particle size analyses have to be reported.

Test animals

- Description of caging conditions, including: number (or change in number) of animals per cage, bedding material, ambient temperature and humidity, photoperiod, and identification of diet of test animals.
- species/strain used; source and historical data
- number, age and sex of animals;
- method of randomisation
- description of any pre-test conditioning, including diet, quarantine and treatment for disease.
- individual weights of animals is indicated above
- LC_{50} , incl. 95% confidence and slope (if provided by the method of the evaluation)
- observation of animals (in tabular form)
- gross pathology (individual findings)
- histological findings (if applicable)

Test conditions

- details of test substance preparation, including details of any procedures used to reduce the particle size of powders or to prepare solutions of the test substance;
- a description (preferably including a diagram) of the equipment used to generate the test atmosphere and to expose the animals to the test atmosphere;
- details of the equipment used to monitor chamber temperature, humidity and airflow;
- details of the equipment used to collect samples for determination of chamber concentration and particle size distribution;
- details of the chemical analytical method used and method validation (including efficiency of recovery of test substance from the sampling medium);
- details for time needed for equilibrium of exposure concentration before animal exposure;
- method of randomisation in assigning animals to test and control groups;
- details of food and water quality (including diet type/source, water source);
- the rationale for the selection of the starting concentration.

Results

- tabulation of chamber temperature, humidity and airflow;
- tabulation of chamber nominal and actual concentration data;
- tabulation of particle size data including analytical sample collection data, particle size distribution and calculations of the MMAD, GSD and per cent respirable mass $<3\mu\text{m}$ (as described in the Guidance Document on Acute Inhalation Toxicity Testing);

- tabulation of response data and concentration level for each animal (*i.e.*, animals showing signs of toxicity including mortality, nature, severity, and duration of effects);
- individual weights of animals at the day of exposure, in weekly intervals thereafter, and at time of death or euthanasia; date and time of death if prior to scheduled euthanasia, time course of onset of signs of toxicity and whether these were reversible for each animal;
- necropsy findings and histopathological findings for each animal, if available.

Discussion and interpretation of results

- particular emphasis should be made to the description of methods used to meet the criteria of this test guideline, *i.e.*, the limit concentration or the particle size.
- the respirability of particles in the light of the overall findings has to be addressed, particularly, if the particle-size criteria could not be met.
- the consistency of methods determining concentrations and the actual concentration found in relation to the nominal concentration needs to be included in the overall assessment of study.
- the likely cause of death and predominant mode of action (systemic versus local) should be addressed.

LITERATURE

- 1) OECD (1981) Test Guideline 403. OECD Guideline for Testing of Chemicals. Acute Inhalation Toxicity Testing.
Available:[http://www.oecd.org/document/22/0,2340,en_2649_34377_1916054_1_1_1_1,00.html]
- 2) Holzhütter, H-G, Genschow, E., Diener, W., Schlede, E (2003) Dermal and Inhalation Acute Toxicity Class Methods: Test Procedures and Biometric Evaluations for the Globally Harmonized Classification System. Archives of Toxicology 77, 243-254
- 3) Diener W., Kayser D. and Schlede E. (1997). The Inhalation Acute-Toxic-Class Method; Test Procedures and Biometric Evaluations. Arch. Toxicol. 71, 537-549.
- 4) Diener W, Schlede E (1999). Acute Toxic Class Methods: Alternatives to LD/LC50 Tests. ALTEX 1: 129-134
- 5) OECD (2001) Test Guideline 423. OECD Guideline for Testing of Chemicals. Acute Oral Toxicity – Acute Toxic Class. Available: [http://www.oecd.org/document/22/0,2340,en_2649_34377_1916054_1_1_1_1,00.html]
- 6) Diener W., Siccha L., Mischke U., Kayser D. and Schlede E. (1994). The Biometric Evaluation of the Acute-Toxic-Class Method (Oral.) Arch. Toxicol. 68, 599-610.
- 7) Diener W., Mischke U., Kayser D. and Schlede E. (1995). The Biometric Evaluation of the OECD Modified Version of the Acute-Toxic-Class Method (Oral). Arch. Toxicol. 69, 729-734.
- 8) Schlede E., Mischke U., Roll R. and Kayser D. (1992). A National Validation Study of the Acute-Toxic-Class Method - An Alternative to the LD50 Test. Arch. Toxicol. 66, 455-470.
- 9) Schlede E., Mischke U., Diener W. and Kayser D. (1994). The International Validation Study of the Acute-Toxic-Class Method (Oral). Arch. Toxicol. 69, 659-670.
- 10) OECD (2000). Guidance Document on the Recognition, Assessment and Use of Clinical Signs as Humane Endpoints for Experimental Animals Used in Safety Evaluation. Environmental Health and Safety Monograph Series on Testing and Assessment No. 19. Available: : [http://www.oecd.org/document/22/0,2340,en_2649_34377_1916054_1_1_1_1,00.html]
- 11) Pauluhn J., Bury D., Föst U., Gamer A., Hoernicke E., Hofmann T., Kunde M., Neustadt T., Schlede E., Schnierle H., Wettig K. and Westphal D. (1996). Acute Inhalation Toxicity Testing: Considerations of Technical and Regulatory Aspects. Arch. Toxicol. 71, 1-10.
- 12) SOT COMMENTARY, Recommendations for the Conduct of Acute Inhalation Limit Tests, Fundam. Appl. Toxicol. 18:321-327 (1992).
- 13) OECD Draft Guidance Document on Acute Inhalation Toxicity Testing. Environmental Health and Safety Monograph Series on Testing and Assessment No. 19. Available: : [http://www.oecd.org/document/22/0,2340,en_2649_34377_1916054_1_1_1_1,00.html]

- 14) United Nations (UN)(2003). Globally Harmonized System of Classification and Labelling of Chemicals (GHS), ST/SG/AC.10/30, UN New York and Geneva. Available: [<http://www.unece.org/trans/danger/publi/ghs/officialtext.html>]
- 15) Van den Heuvel, M. J., Clark, D. G., Fielder, R. J., Koundakjian, P. P., Oliver, G. J. A., Pelling, D., Tomlinson, N. J. and Walker, A. P. (1990). The international validation of a fixed-dose procedure as an alternative to the classical LD50 test. *Fd. Chem. Toxicol.*, 28, 469-482.
- 16) Phalen R.F. (1984). *Inhalation Studies: Foundations and Techniques*. CRC Press, Boca Raton, Florida.

ANNEX 1

DEFINITIONS

Acute inhalation toxicity is the total of adverse effects caused by a substance following a single uninterrupted exposure by inhalation over a short period of time to an airborne substance.

Aerodynamic diameter applies to the behavioural size of particles of aerosols. It is the diameter of a sphere unit density which behaves aerodynamically as the particle of the test substance. It is used to compare particles of different sizes, shapes, and densities to predict where in the respiratory tract such particles may be deposited. This term is used in contrast to "optical", "measured", or "geometric diameter" which is a representation of actual diameters which in themselves cannot be related to deposition within the respiratory tract.

Aerosol: A suspension of solid or liquid particles in a suspension in a gas, as a foam, paste or powder or in a liquid state or in a gaseous state.

Analytical or actual concentrations refer to concentrations obtained by sampling of test atmosphere in that location of an inhalation chamber which is being inhaled by the test species investigated. Hazard assessment can only be performed on the basis of this exposure concentrations. Nominal concentrations are irrelevant for hazard assessment since it depends heavily on specific procedures and may differ from one laboratory to another. Reactive test substances may decompose in humid chamber atmospheres which is only addressed adequately by analytical concentrations.

Concentration is expressed as weight of the test substance per unit volume of air, for vapours and dusts as mg/L and for gases as ppm (parts per million), in accordance with the UN GHS (13).

Dust: Solid particles formed from a substance or mixture, capable of being suspended in air. These particles may have irregular shapes with sizes ranging from sub-micrometer up to over 100 µm.

Evident toxicity is a general term describing clear signs of toxicity following the administration of a test substance, (see Van den Heuvel *et al.*, 1990 (15) for examples) such that at the next highest fixed concentration either severe pain and enduring signs of severe distress, moribund condition (criteria are presented in the Humane Endpoints Guidance Document (10)) or probable mortality in most animals can be expected.

Exposure concentration is the actual concentration of test substance the test animal is exposed to. It is determined by the analytical characterisation of the test atmosphere in the vicinity of the breathing zone of the animals exposed. It is commonly expressed in mass (mg) per unit volume (L) of air. The mass of test substance per unit mass of test animal (*e.g.*, mg/kg) which is equal the dose, is difficult to define in inhalation toxicity since the fraction of substance absorbed/retained in the respiratory tract or absorbed via the gastrointestinal tract is dependent on a number of variable often not defined or measured in acute inhalation studies. Due to these uncertainties, exposure should be defined in terms of "exposure concentrations" rather than "exposure doses".

Geometric standard deviation (GSD) (see Mass Median Aerodynamic Diameter (MMAD)).

GHS - Globally Harmonized System of Classification and Labelling of Chemicals: a system proposing the classification of chemicals according to standardised types and levels of physical, health and environmental hazards, and addressing corresponding communication elements, such as pictograms, signal words, hazard statements, precautionary statements and safety data sheets, so that to convey information on

their adverse effects with a view to protect people and the environment. A joint activity of OECD (human health and the environment), UN Committee of Experts on Transport of Dangerous Goods (physical-chemical properties) and ILO (hazard communication) and co-ordinated by the Interorganisation Programme for the Sound Management of Chemicals (IOMC) (13).

Impending death: when moribund state or death is expected prior to the next planned time of observation. Signs indicative of this state in rodents could include convulsions, lateral position, recumbence, and tremor. (See the Humane Endpoint Guidance Document (10) for more details).

Inhalable diameter refers to that aerodynamic diameter of a particle which is considered to be inhalable for the test species. It is used to refer to particles which are capable of being inhaled and may be deposited anywhere within the entire respiratory tract from the nose to the alveoli.

LC₅₀ (median lethal concentration) is a statistically derived estimate of a concentration of a substance that can be expected to cause death during exposure or within a fixed time after exposure in 50 percent of animals exposed for a specified time. The LC₅₀ value is expressed as weight of test substance per unit volume of air (mg/L). For gases parts per million may also be used. For clarity, the exposure duration should also be specified, *e.g.*, 4-h LC₅₀.

Mass Median Aerodynamic Diameter (MMAD) is the calculated aerodynamic diameter which divides the particles of an aerosol in half based on mass of the particles. Fifty per cent of the particles by mass will be larger than the median diameter and fifty per cent of the particles will be smaller than the median diameter. The median diameter and its **geometric standard deviation (GSD)** is used to statistically describe the particle-size distribution of any aerosol (liquid or solid) based on the mass size of the particles.

Mist: Finely divided liquid droplets of a substance or mixture suspended in air with sizes generally ranging from 2 to 100 µm. A mist can be formed by condensation of supersaturated vapours or by physical shearing of liquids, such as nebulization, atomisation, spraying or bubbling.

Moribund status: being in a state of dying or inability to survive, even if treated. (See the Humane Endpoint Guidance Document (2) for more details).

Respirable particulate mass: Mass of material that is deposited in the gas-exchange region.

Vapour: The gaseous form of a substance or mixture which is normally in liquid or solid state at ambient conditions of temperature and pressure.

ANNEX 2

CRITERIA FOR CLASSIFICATION OF TEST SUBSTANCES WITH EXPECTED LC₅₀ VALUES EXCEEDING CUT-OFF VALUES OF CLASS 4 WITHOUT THE NEED FOR TESTING

1. Criteria for hazard Category 5 are intended to enable the identification of test substances which are of relatively low acute toxicity hazard but which, under certain circumstances may present a danger to vulnerable populations. These substances are anticipated to have an inhalative LC₅₀-value in the range of 20-50 mg/L/4h for vapours; 5–10 mg/L/4h for dusts and mists and 5000–10000 ppm/4 h for gases and should be classified in hazard category 5 in the following cases:

a) If directed to this category by any of the testing schemes of Annex 3-5, based on mortality incidences;

b) if reliable evidence is already available that indicates the LC₅₀ to be in the range of Category 5 values, or other animal studies or toxic effects in humans indicate a concern for human health of an acute nature.

c) Through extrapolation, estimation or measurement of data if assignment to a more hazardous category is not warranted, and

- reliable information is available indicating significant toxic effects in humans; or,
- any mortality is observed when tested up to Category 4 values by the inhalation route; or,
- where expert judgement confirms significant clinical signs of toxicity, when tested up to Category 4 values, except for diarrhoea, piloerection or an un-groomed appearance; or,
- where expert judgement confirms reliable information indicating the potential for significant acute effects from the other animal studies.

TESTING AT CONCENTRATIONS ABOVE THE LIMIT CONCENTRATIONS (CATEGORY 4)

2. Recognising the need to protect animal welfare, testing of animals at concentrations as outlined in Category 5 is discouraged and should only be considered when there is a strong likelihood that results of such a test have a direct relevance for protecting human or animal health (9). No further testing should be conducted at higher concentration levels.

3. When testing is required at a concentration of Category 5, only one step (*i.e.*, three male animals) is required. If one or two exposed animals die, then testing proceeds at concentrations used for Category 4 in accordance with the flow charts in Annex 3-5.

Annex 3

PROCEDURE TO BE FOLLOWED BY EACH OF THE STARTING CONCENTRATIONS FOR GASES (ppm/4h)

GENERAL REMARKS

For each starting concentration, the respective testing schemes as included in this Annex outline the procedure to be followed.

Annex 3 a: Starting concentration is 100 ppm
Annex 3 b: Starting concentration is 500 ppm
Annex 3 c: Starting concentration is 2500 ppm
Annex 3 c: Starting concentration is 5000 ppm

Depending on the number of humanely killed or dead animals, the test procedure follows the indicated arrows

ANNEX 3a

Acute Inhalation Toxicity:

Test Procedure with a starting concentration of 100 ppm/4 h for gases

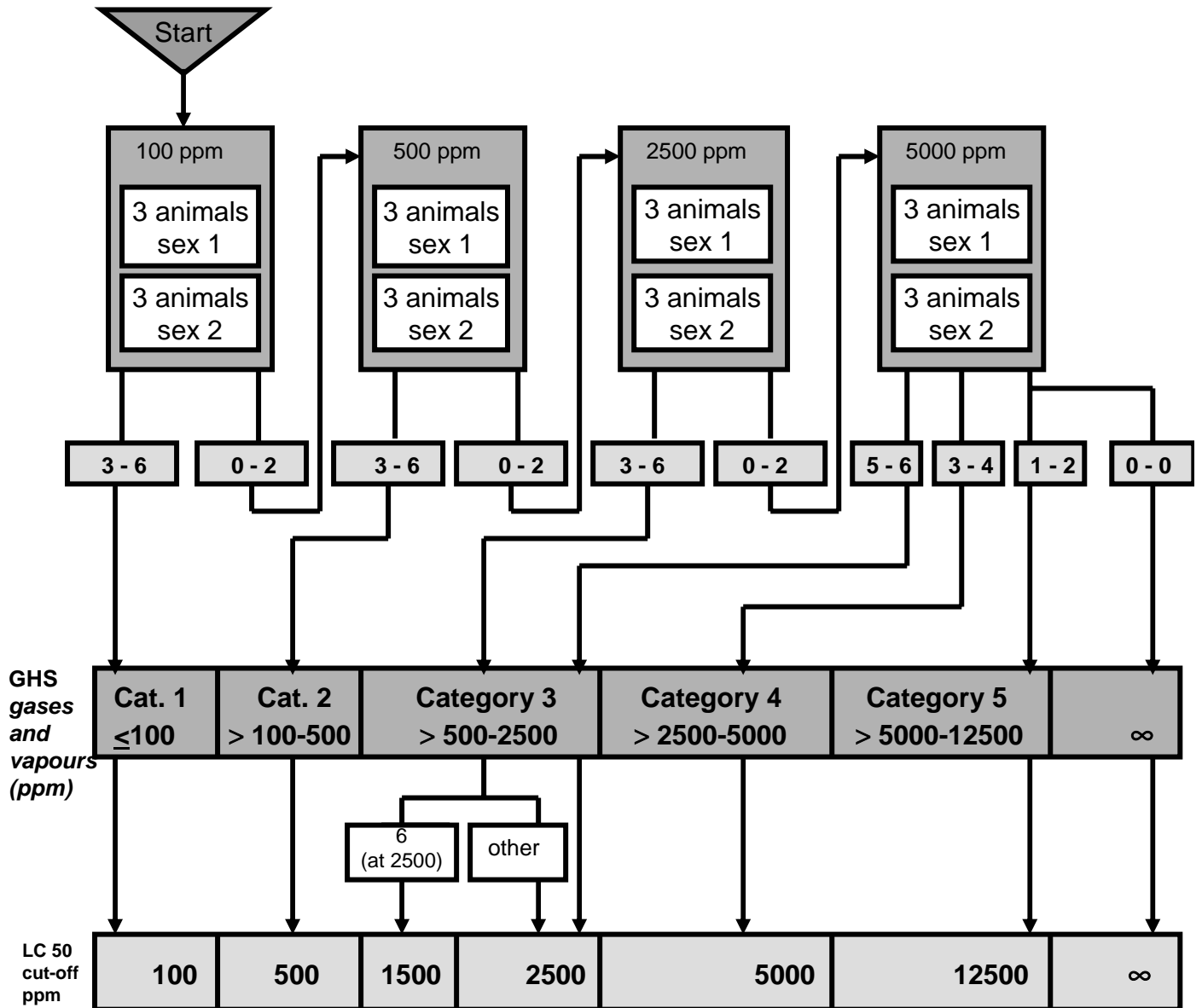

- per step three animals of a single sex are used
- 0-6: Number of moribund or dead animals/tested concentration
- GHS: Globally Harmonized Classification System
- ∞ : unclassified
- Testing at ≥ 5000 ppm/4h: see Annex 2

ANNEX 3b

Acute Inhalation Toxicity:

Test Procedure with a starting concentration of 500 ppm/4h for gases

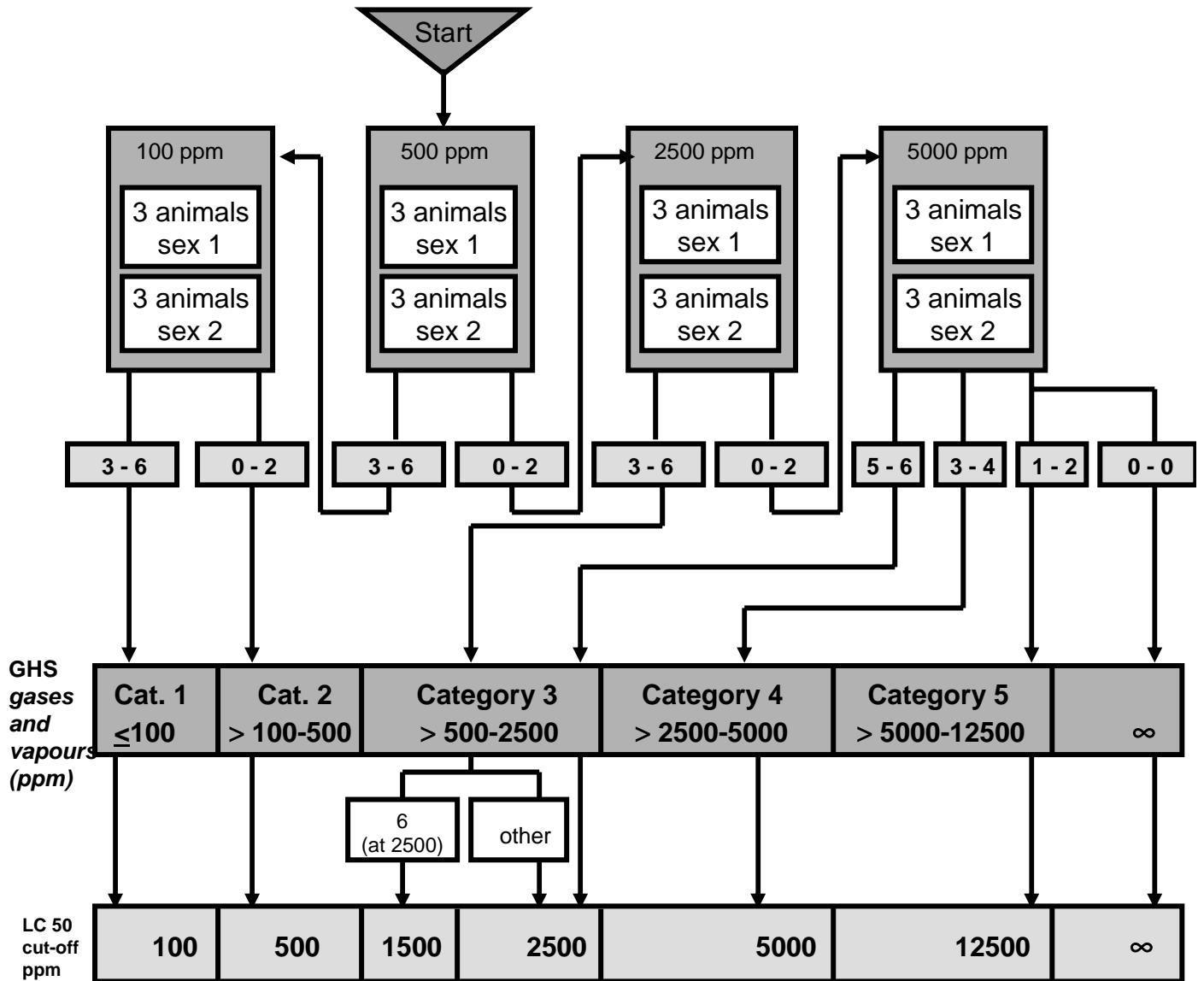

- per step three animals of a single sex are used
- 0-6: Number of moribund or dead animals/tested concentration
- GHS: Globally Harmonized Classification System
- ∞ : unclassified
- Testing at ≥ 5000 ppm/4h: see Annex 2

ANNEX 3c

Acute Inhalation Toxicity:

Test Procedure with a starting concentration of 2500 ppm/4h for gases

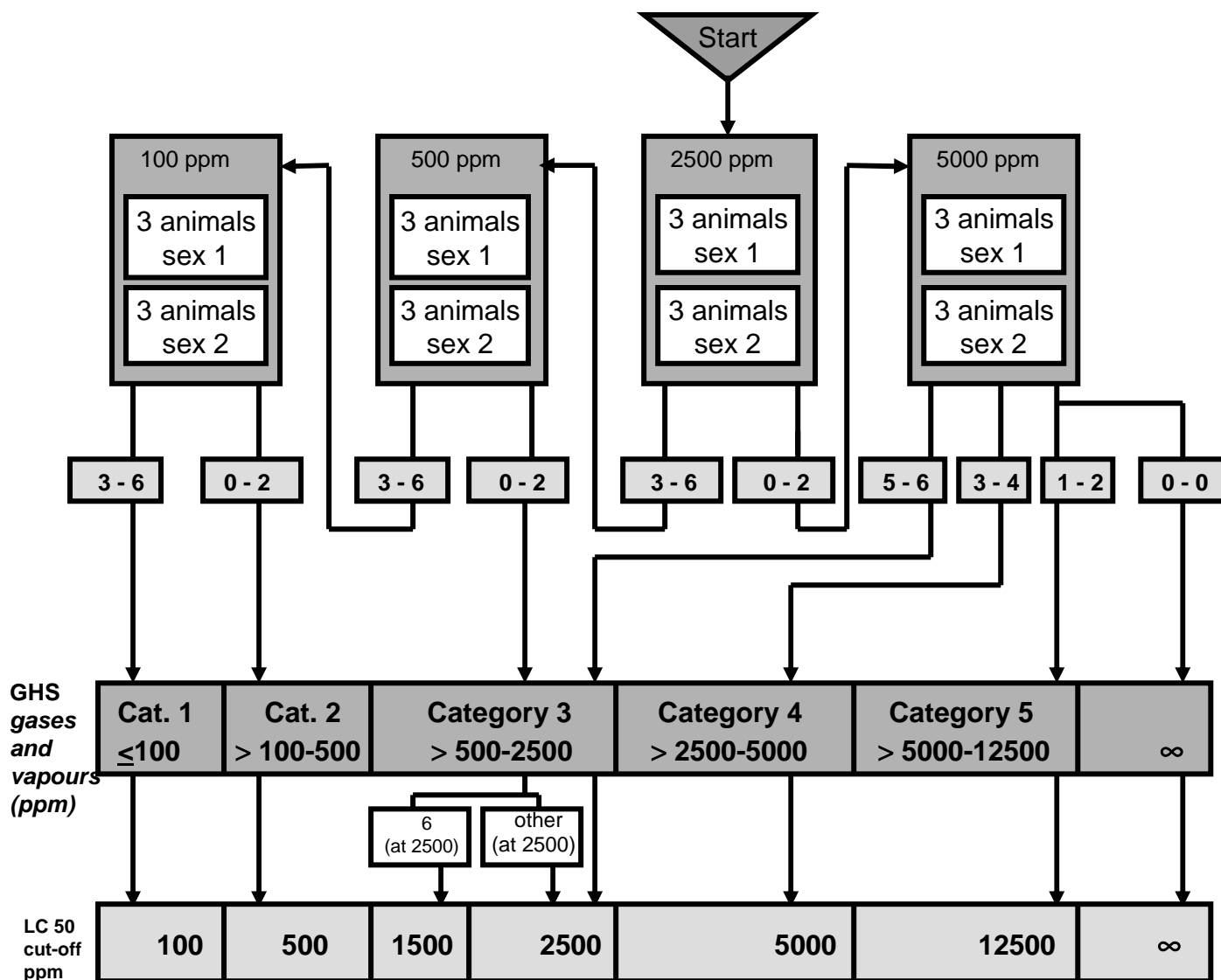

- per step three animals of a single sex are used
- 0-6: Number of moribund or dead animals/tested concentration
- GHS: Globally Harmonized Classification System
- ∞: unclassified
- Testing at ≥ 5000 ppm/4h: see Annex 2

Annex 4

PROCEDURE TO BE FOLLOWED BY EACH OF THE STARTING CONCENTRATIONS FOR VAPOUR (mg/L/4h)

GENERAL REMARKS

For each starting concentration, the respective testing schemes as included in this Annex outline the procedure to be followed.

Annex 3 a: Starting concentration is 0.2 mg/L

Annex 3 b: Starting concentration is 2.0 mg/L

Annex 3 c: Starting concentration is 10 mg/L

Annex 3 c: Starting concentration is 20 mg/L

Depending on the number of humanely killed or dead animals, the test procedure follows the indicated arrows

ANNEX 4a

Acute Inhalation Toxicity:

Test procedure with a starting concentration of 0.5 mg/L/4h for vapours and gases

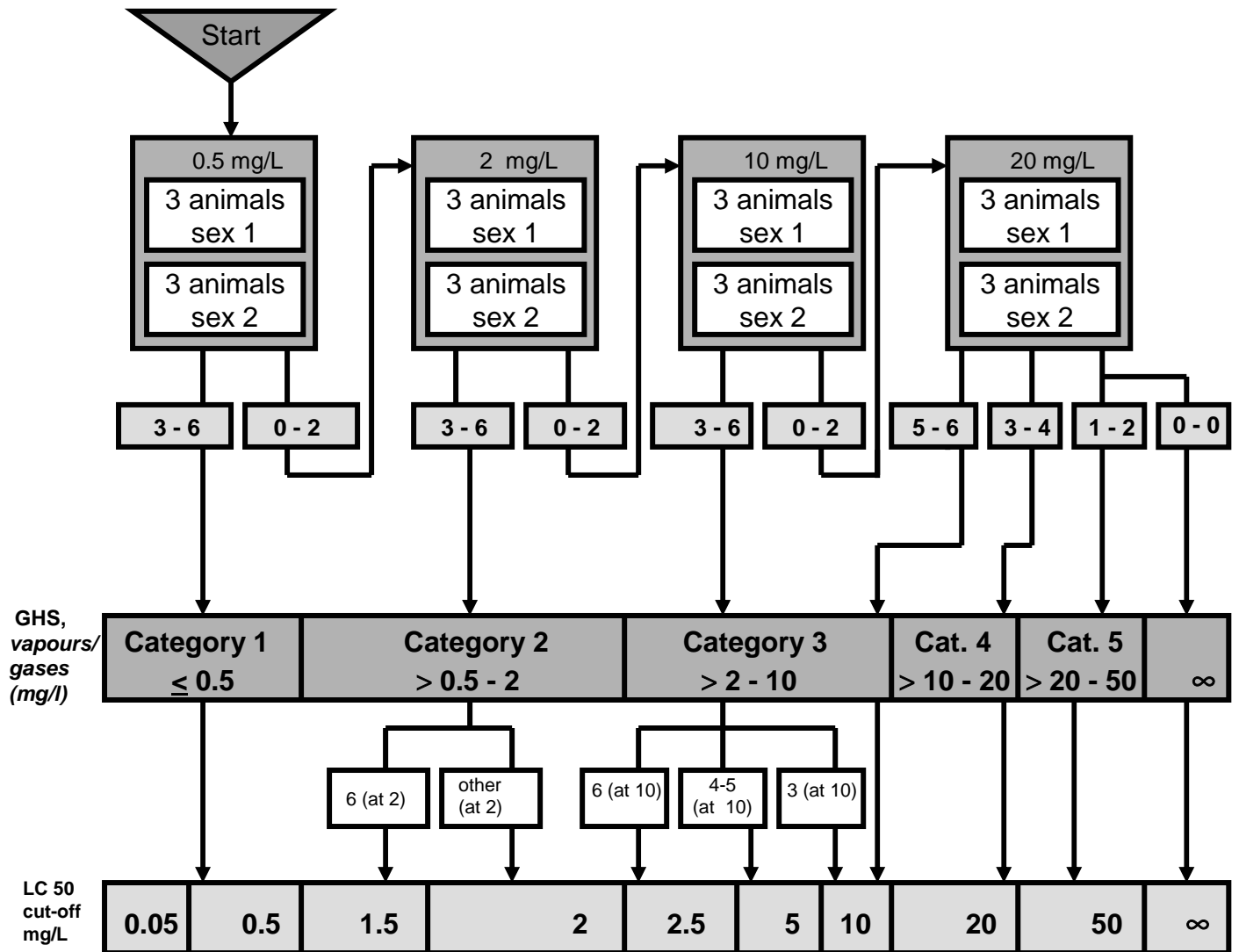

- per step three animals of a single sex are used
- 0-6: Number of moribund or dead animals/tested concentration
- GHS: Globally Harmonized Classification System
- ∞ : unclassified
- Testing at 50 mg/L/4h: see Annex 2

ANNEX 4b

Acute Inhalation Toxicity:

Test procedure with a starting concentration of 2 mg/L/4h for vapours and gases

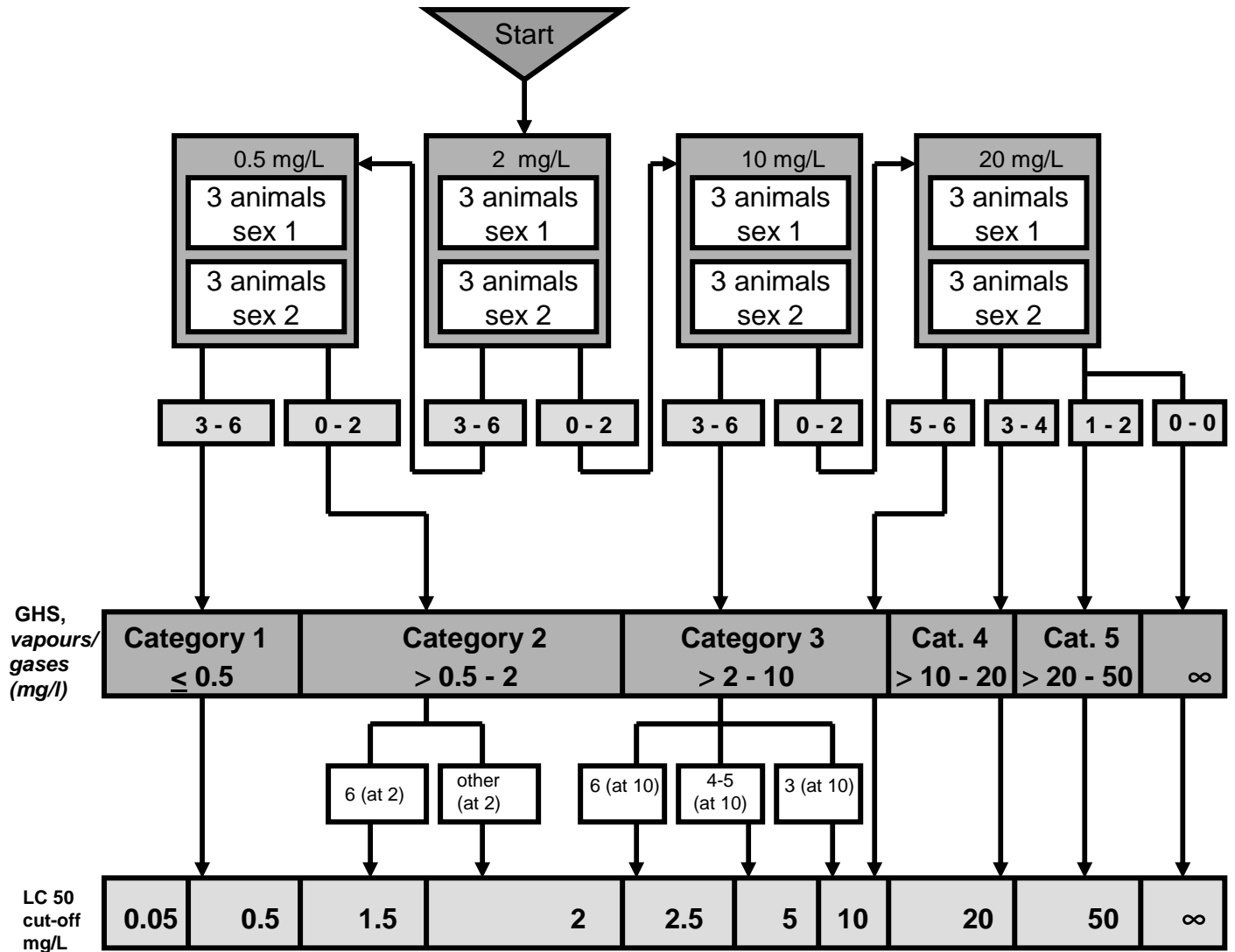

- per step three animals of a single sex are used
- 0-6: Number of moribund or dead animals/tested concentration
- GHS: Globally Harmonized Classification System
- ∞ : unclassified
- Testing at 50 mg/L/4h: see Annex 2

ANNEX 4c

Acute Inhalation Toxicity:

Test procedure with a starting concentration of 10 mg/L/4h for vapours and gases

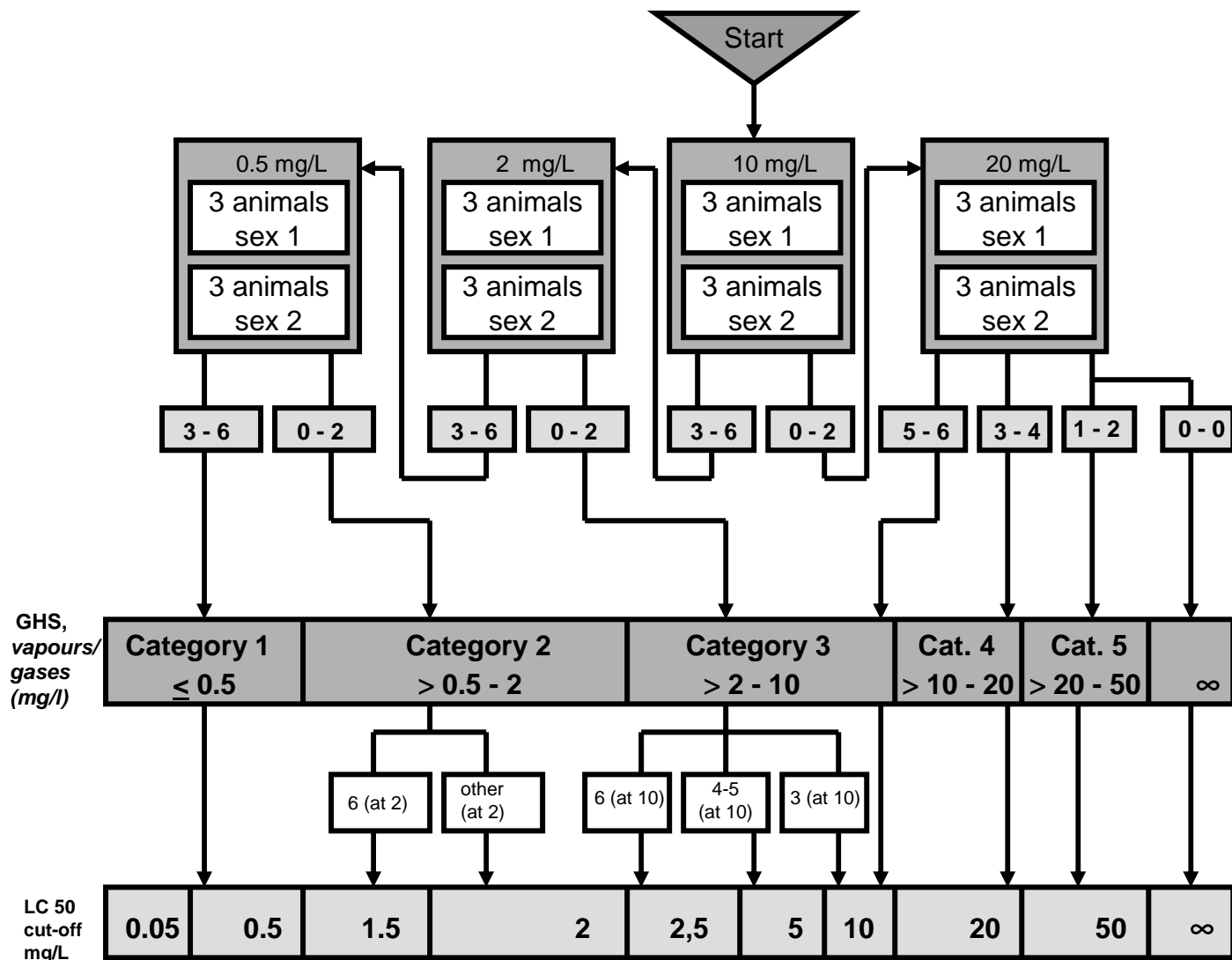

- per step three animals of a single sex are used
- 0-6: Number of moribund or dead animals/tested concentration
- GHS: Globally Harmonized Classification System
- ∞ : unclassified
- Testing at 50 mg/L/4h: see Annex 2

ANNEX 4d

Acute Inhalation Toxicity:

Test procedure with a starting concentration of 20 mg/L/4h for vapours and gases

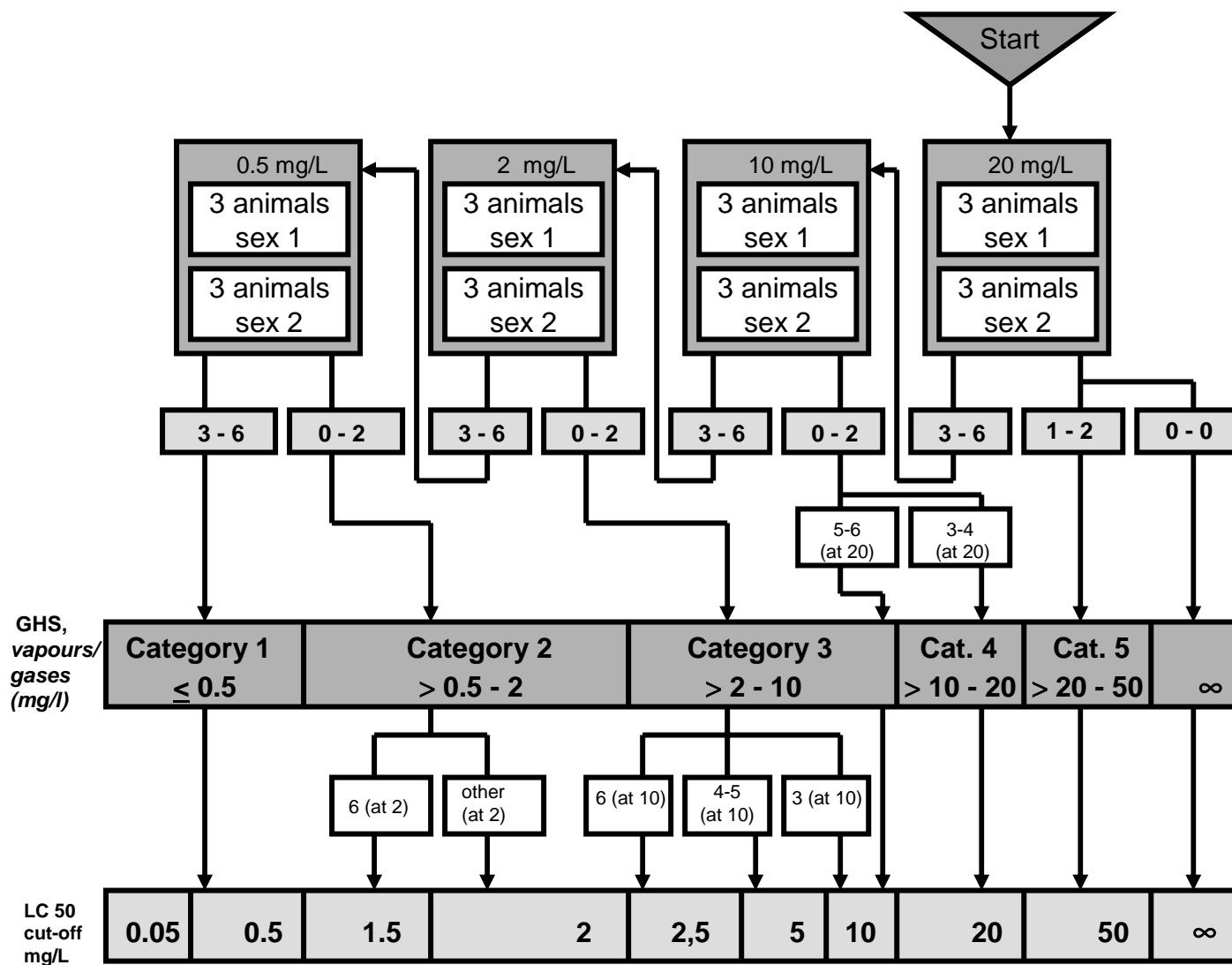

- per step three animals of a single sex are used
- 0-6: Number of moribund or dead animals/tested concentration
- GHS: Globally Harmonized Classification System
- ∞: unclassified
- Testing at 50 mg/L/4h: see Annex 2

Annex 5

PROCEDURE TO BE FOLLOWED BY EACH OF THE STARTING CONCENTRATIONS FOR DUSTS AND MISTS (mg/L/4h)

GENERAL REMARKS

For each starting concentration, the respective testing schemes as included in this Annex outline the procedure to be followed.

Annex 3 a: Starting concentration is 0.05 mg/L

Annex 3 b: Starting concentration is 0.5 mg/L

Annex 3 c: Starting concentration is 1 mg/L

Annex 3 c: Starting concentration is 5 mg/L

Depending on the number of humanely killed or dead animals, the test procedure follows the indicated arrows

ANNEX 5a

Acute Inhalation Toxicity:

Test procedure with a starting concentration of 0.05 mg/L/4h for dusts and mists

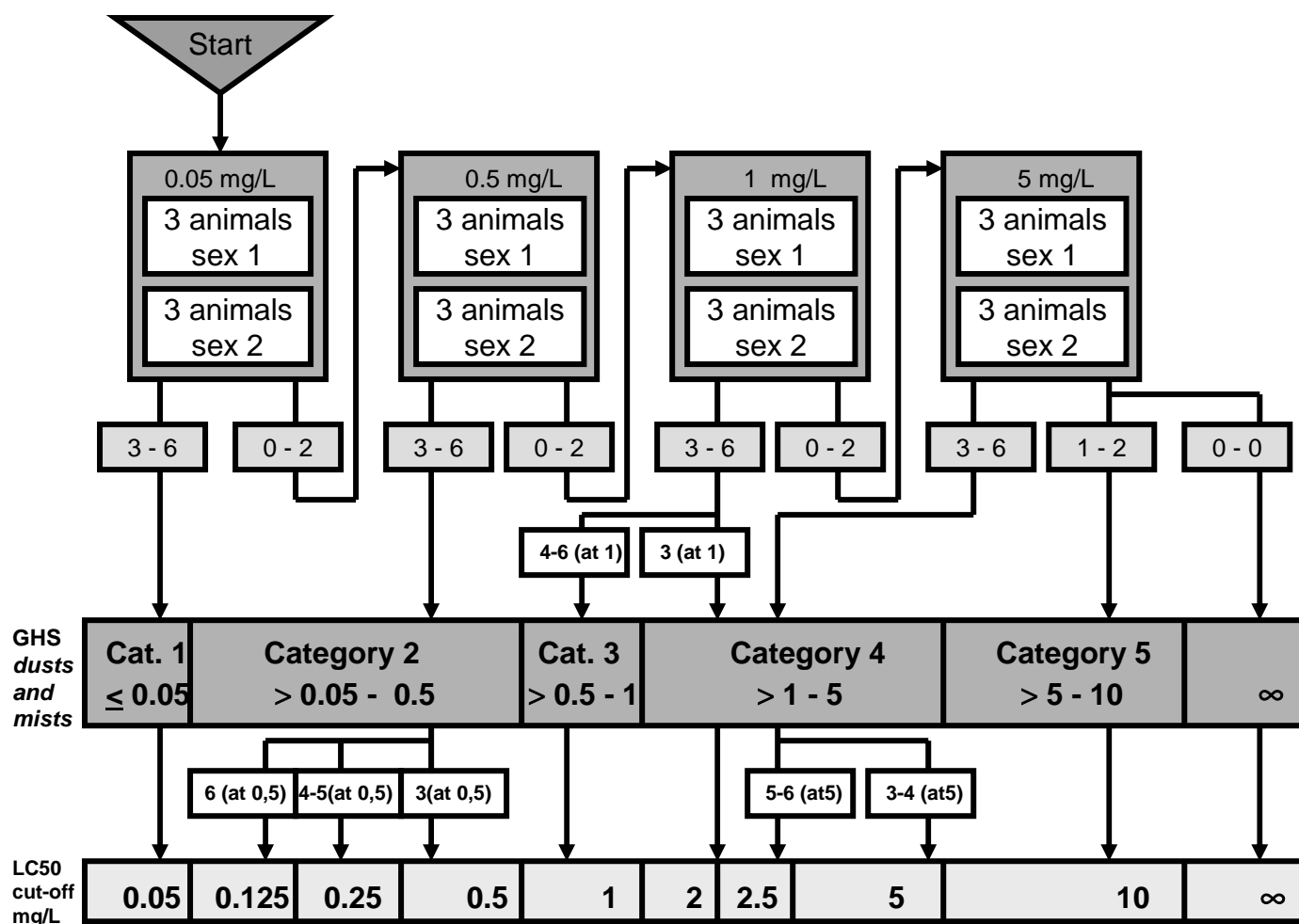

- per step three animals of a single sex are used
- 0-6: Number of moribund or dead animals/tested concentration
- GHS: Globally Harmonized Classification System
- ∞ : unclassified
- Testing at 10 mg/L/4h: see Annex 2

ANNEX 5b

Acute Inhalation Toxicity:

Test procedure with a starting concentration of 0.5 mg/L/4h for dusts and mists

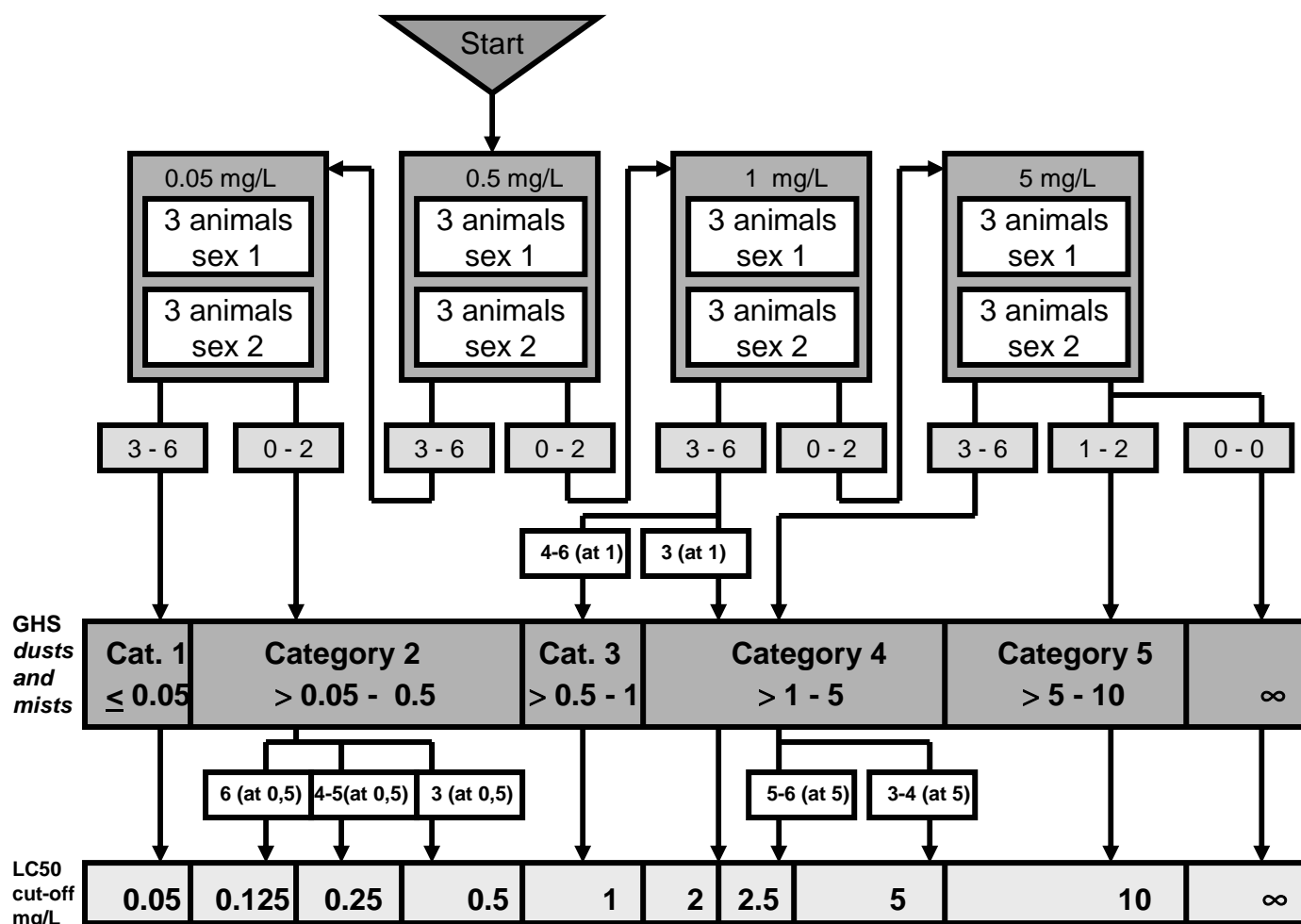

- per step three animals of a single sex are used
- 0-6: Number of moribund or dead animals/tested concentration
- GHS: Globally Harmonized Classification System
- ∞: unclassified
- Testing at 10 mg/L/4h: see Annex 2

ANNEX 5c

Acute Inhalation Toxicity:

Test procedure with a starting concentration of 1 mg/L/4h for dusts and mists

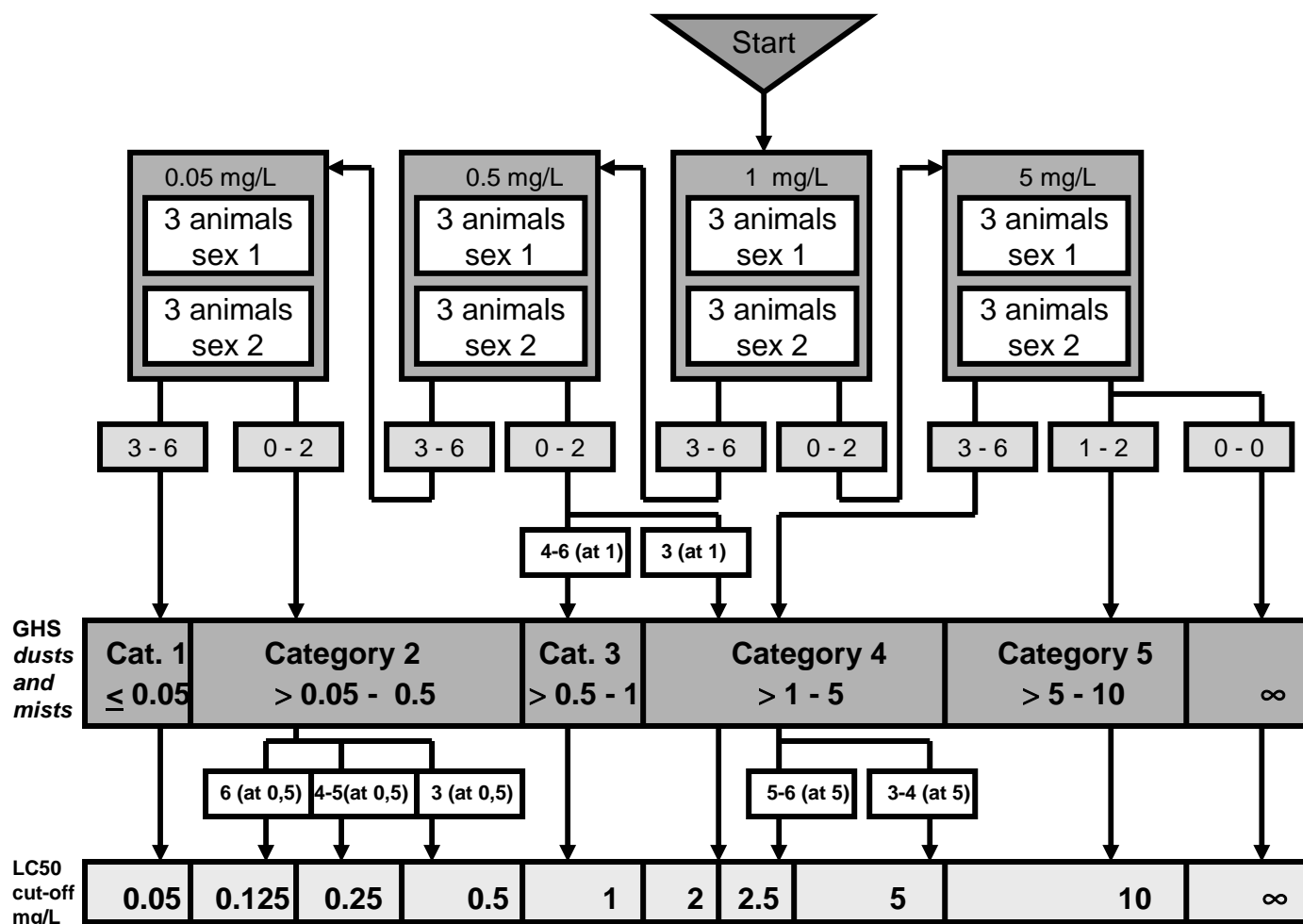

- per step three animals of a single sex are used
- 0-6: Number of moribund or dead animals/tested concentration
- GHS: Globally Harmonized Classification System
- ∞: unclassified
- Testing at 10 mg/L/4h: see Annex 2

ANNEX 5d

Acute Inhalation Toxicity:

Test procedure with a starting concentration of 5 mg/L/4h for dusts and mists

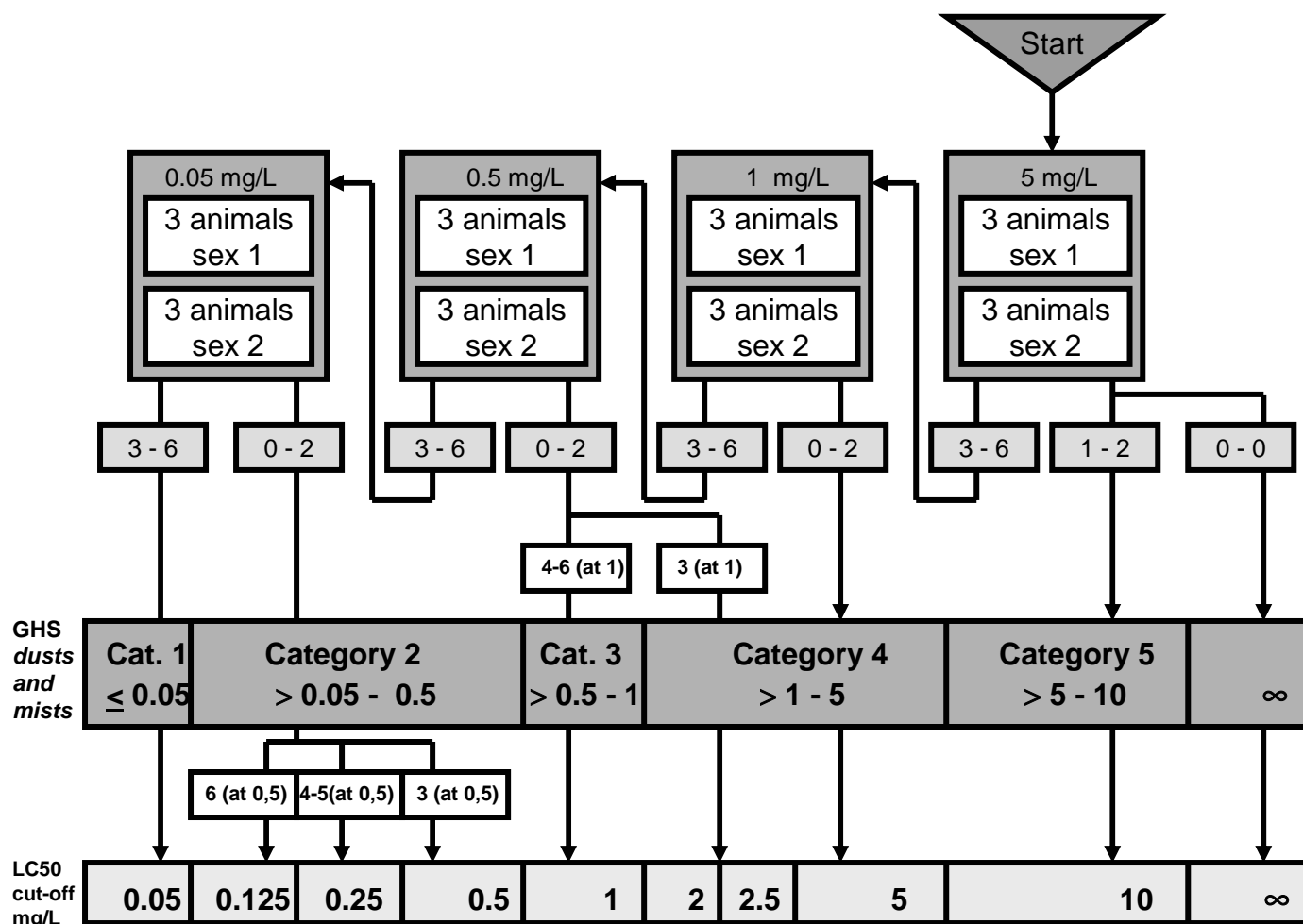

- per step three animals of a single sex are used
- 0-6: Number of moribund or dead animals/tested concentration
- GHS: Globally Harmonized Classification System
- ∞: unclassified
- Testing at 10 mg/L/4h: see Annex 2