



## The Next Round of IT Innovation – Resource and Energy Efficient Microprocessing

Silke Hermanns  
Program Manager EPR Europe  
Global Environmental Health and Safety

Why Energy Efficiency?

IT and Energy Consumption – Scoping the Challenge

European and Global IT Initiatives

Enabling a Greener IT  
Energy Efficient Microprocessors – Design, Manufacture, Usage

# Energy Efficiency

## A Look from the Lifecycle Perspective

- Energy efficiency is an important aspect of resource efficiency within a product lifecycle assessment (LCA).
- Energy usage and material usage both contribute to LCA environmental impact categories, as analyzed in an internal AMD pilot LCA for some selected microprocessors (2005 and 2007).
- When only looking at the manufacturing phase of a microprocessor's lifecycle, total manufacturing energy together with and the supply chain of copper dominate the considered relevant environmental impact categories.
- However, the energy need of a microprocessor during its lifetime active use phase dominates all of the relevant LCA-considered environmental impact categories.
- Therefore, the LCA-derived impacts associated with combined energy use in a microprocessor's manufacturing and active use phases significantly exceeds the contribution of materials use in manufacturing alone.

## “Leading the world to Energy-Efficient Processing”

AMD  
PowerNow!  
TECHNOLOGY



- **Products** based on technologies that address the need to optimize energy use



- **Initiatives** that address improved energy-efficient solutions and influence public policies

Sustainable Manufacturing and Design



- **Operational Behaviors** that address responsibility related to energy and the environment

## Partnerships Addressing IT and Energy Efficiency

### Scoping the Challenge:

- AMD-sponsored Alliance To Save Energy study, "*Energy Efficiency in Datacenters: A New Policy Frontier*"
- AMD commissioned two studies by Dr. Jonathan Koomey (2007): worldwide datacenter energy use *doubled* between 2000 and 2005
- EPA Server and Datacenter Energy Efficiency report - August 2007
- WEF: The Contribution of ICT to Climate Change Mitigation; January 2008: statements on the potential contribution of ICT to climate change mitigation

### Collaboration with Government, Industry, and Customers:

- AMD is a charter member of the ENERGY STAR Low Carbon IT Campaign that was launched on April 3, 2008
- AMD is a founding member of The Green Grid™
- AMD is also a founding sponsor of the Climate Savers Computing Initiative™

# Performance per Watt Scalability

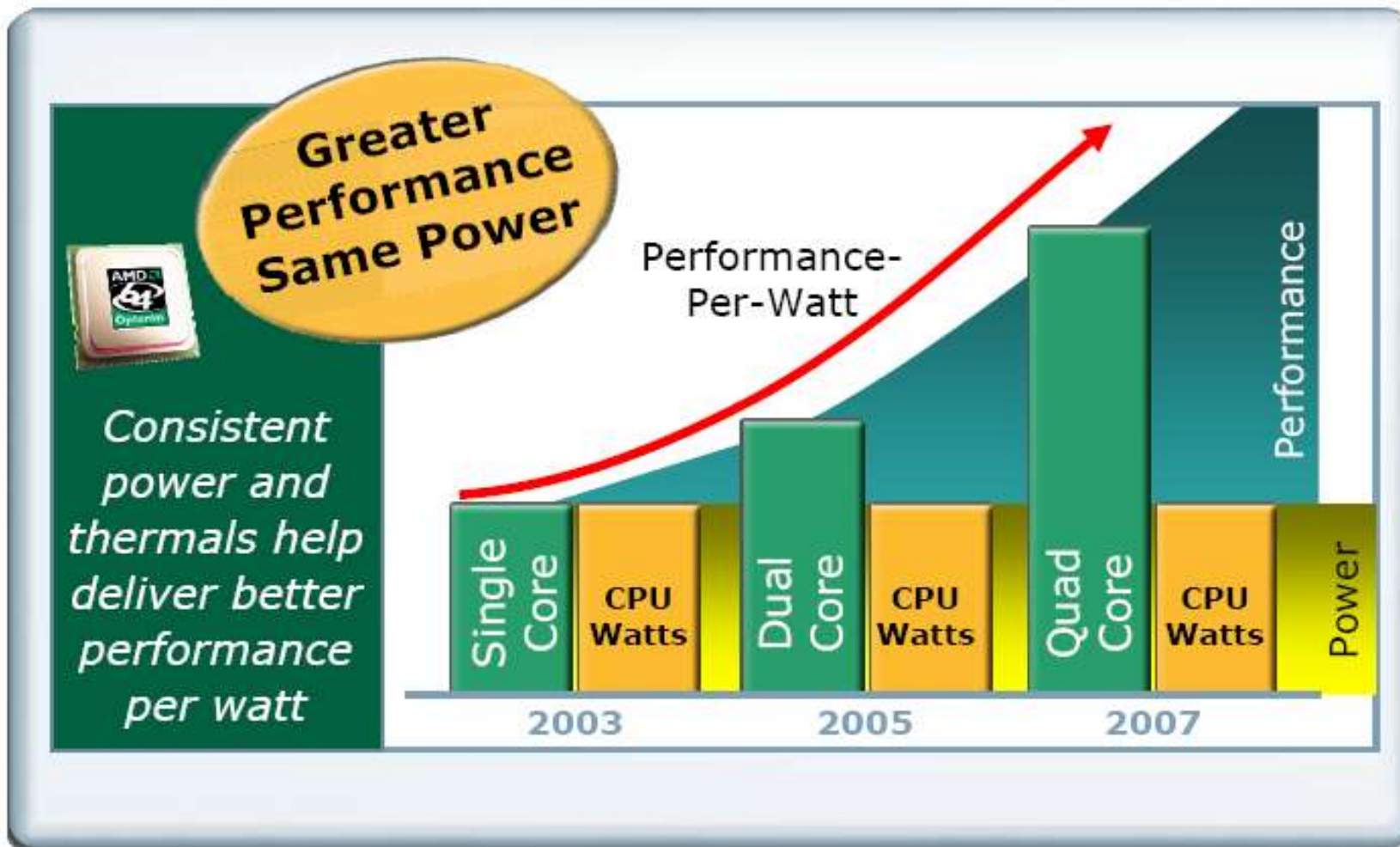

## Independent Dynamic Core Technology

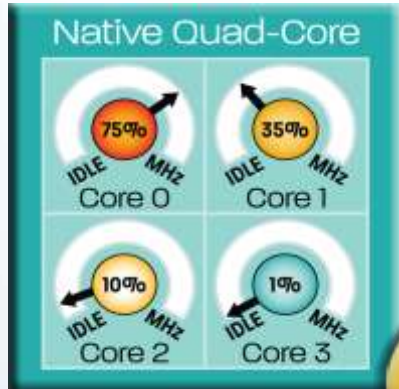

## AMD CoolCore™ Technology

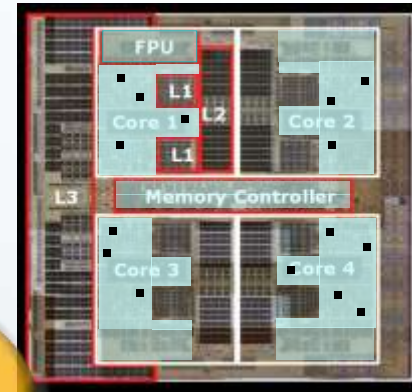

**Same Power/Thermals As Dual-Core!**

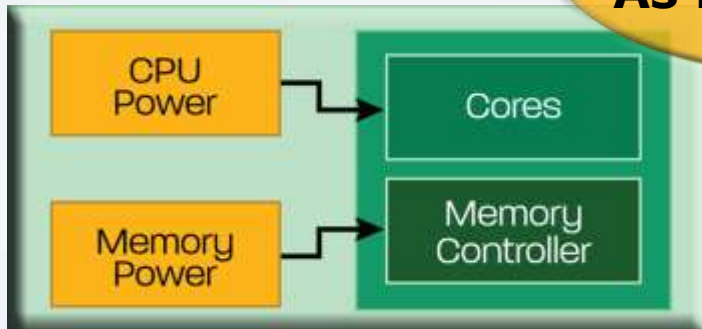

## Dual Dynamic Power Management™



## Enhanced AMD PowerNow!™ Technology

# AMD Green: Global Climate Protection Plan 2007



First published in 2001, GCPP integrates **products, operations,** and **people**

Presents AMD strategy, actions, and emissions reporting

AMD exceeded its Climate Leaders goal to reduce normalized greenhouse gas emissions 40% by 2007 – actual reduction ***greater than 50%***

AMD set **new goals** to:

- Further reduce normalized greenhouse gas emissions by **33 percent by 2010** (against a baseline year of 2006)
- Further reduce normalized energy use by **40 percent by 2010** (against a baseline year of 2006)

**[www.amd.com/climate](http://www.amd.com/climate)**

# Low-Carbon Energy Sources

## Trigeneration for Manufacturing in Dresden, Germany

- Natural gas-fueled trigeneration for electricity, heating, cooling
- Avoided more than 800,000 t CO<sub>2</sub> emissions (1998 to 2007); in 2006 alone, almost 175,000 t CO<sub>2</sub> compared to a conventional energy supply
- 175,000 t CO<sub>2</sub>: More than 3.5% of annual GHG emissions of city of Dresden;
- EVC II elected "Cogeneration plant of the year 2007" in Germany

## U.S. Green Power Purchases

In 2001, AMD became one of the first companies to purchase renewable energy through Austin Energy's GreenChoice® Program

First member of the semiconductor industry to join the U.S. EPA's Green Power Partnership

AMD's new corporate campus has committed to using 100 percent GreenChoice energy from Austin Energy



# Conclusion

- Energy efficiency is an important aspect of resource efficiency
- Energy efficiency has become an innovation driver and a differentiating competitive feature in the IT industry
- Partnership and initiatives within industry and with governments are important to drive energy efficiency of IT products
- IT has the potential to also be the solution of some problems
- Resource and energy efficiency needs to be addressed along the whole life cycle



### Trademark Attribution

AMD, the AMD Arrow logo, PowerNow!, Cool'n'Quiet, AMD Virtualization, AMD CoolCore, Dual Dynamic Power Management, and combinations thereof are trademarks of Advanced Micro Devices, Inc. in the United States and/or other jurisdictions. Energy Star is a registered trademark of the United States Government. The Green Grid is a trademark of The Green Grid Association. Climate Savers is a trademark of the Climate Savers Computing Initiative. Green Choice is a trademark of Austin Energy. Other names used in this presentation are for identification purposes only and may be trademarks of their respective owners.