

CODE 5

**OECD STANDARD CODE
FOR THE OFFICIAL MEASUREMENT
OF NOISE AT THE DRIVING POSITION(S)
ON AGRICULTURAL AND FORESTRY TRACTORS**

TABLE OF CONTENTS

1. DEFINITIONS	3
1.1 Agricultural and forestry tractors	3
1.2 Rolling Over Protective Structure (ROPS).....	3
1.3 Determination of seat index point; Seat adjustment for test.....	3
1.4 Rated speed.....	4
1.5 Power take-off power	4
1.6 Unballasted mass	4
1.7 Permissible measurement tolerances	4
2. RULES AND DIRECTIONS	4
2.1 General regulations.....	4
2.2 Test conditions.....	6
2.3 Measurement method	6
2.4 Sound level test.....	7
2.5 Extension to other models of tractors	8
SPECIMEN TEST REPORT	11
1. STRENGTH TEST REPORT REFERENCE.....	11
2. SPECIFICATIONS OF TEST TRACTOR	11
3. SPECIFICATIONS OF PROTECTIVE STRUCTURE.....	13
4. TEST RESULTS	14
SPECIMEN TECHNICAL EXTENSION REPORT	16
1. STRENGTH TEST REPORT REFERENCE.....	16
2. SPECIFICATIONS OF TEST TRACTOR	17
3. SPECIFICATIONS OF PROTECTIVE STRUCTURE.....	18
4. CONCLUSION	19
ADMINISTRATIVE EXTENSION REPORT	22
ANNEX 1 CLEARANCE ZONE REFERRED TO THE SEAT REFERENCE POINT.....	23
INTRODUCTION	24
1. DEFINITIONS	24
1.3 Determination of seat reference point; Seat location and adjustment for test	24
2. RULES AND DIRECTIONS	25
2.3 Measurement method	25

CODE 5

OECD STANDARD CODE FOR THE OFFICIAL MEASUREMENT OF NOISE AT THE DRIVING POSITION(S) ON AGRICULTURAL AND FORESTRY TRACTORS

1. DEFINITIONS

1.1 *Agricultural and forestry tractors*

Self-propelled wheeled vehicles, having at least two axles, or with tracks, designed to carry out the following operations, primarily for agricultural and forestry purposes:

- to pull trailers;
- to carry, pull or propel agricultural and forestry tools or machinery and, where necessary, supply power to operate them with the tractor in motion or stationary.

1.2 *Rolling Over Protective Structure (ROPS)*

Roll-over protective structure (safety cab or frame), hereinafter called “protective structure”, means the structure on a tractor the essential purpose of which is to avoid or limit risks to the driver resulting from roll-over of the tractor during normal use.

The roll-over protective structure is characterized by the provision of space for a clearance zone large enough to protect the driver when seated either inside the envelope of the structure or within a space bounded by a series of straight lines from the outer edges of the structure to any part of the tractor that might come into contact with flat ground and that is capable of supporting the tractor in that position if the tractor overturns.

1.3 *Determination of seat index point; Seat adjustment for test*

1.3.1 Seat index point (SIP)¹

The seat index point shall be determined in accordance with ISO 5353:1995.

1.3.2 Seat location and adjustment for test

1.3.2.1 any suspension of the seat shall be depressed until the seat reaches the midpoint of its dynamic range;

1.3.2.2 where the position of the seat is adjustable only lengthwise and vertically, the longitudinal axis passing through the seat index point shall be parallel with the vertical longitudinal plane of the tractor passing through the centre of the steering wheel and not more than 100 mm from that plane.

¹ For extension tests to test reports that originally used seat reference point (SRP), the required measurements shall be made with reference to SRP instead of SIP and the use of SRP shall be clearly indicated (see Annex 1).

1.4 *Rated speed*

The engine speed specified by the manufacturer for continuous operation at full load.

1.5 *Power take-off power*

The power measured at the shaft designed to transmit the full power of the tractor; if this shaft is not present, the power should be measured at any other one designed by the tractor manufacturer to be used as a power take-off.

1.6 *Unballasted mass*

The mass of the tractor without ballasting devices and, in the case of tractors with pneumatic tyres, without liquid ballast in the tyres. The tractor shall be in running order with tanks, circuits and radiator full, protective structure with cladding and any track equipment or additional front wheel drive components required for normal use. The operator is not included.

1.7 *Permissible measurement tolerances*

Rotational speed ± 0.5 %
Time ± 0.2 s
Distance ± 0.5 %
Force ± 1.0 %
Mass ± 0.5 %
Atmospheric pressure ± 0.2 kPa
Tyre pressure ± 5.0 %

2. RULES AND DIRECTIONS

2.1 *General regulations*

2.1.1 Selection

The tractor submitted for the test shall be taken from series production by the manufacturer with the agreement of the testing station.

The tractor shall be a production model in all respects, strictly conforming to the description and specification sheet submitted by the manufacturer; this description must accurately define the model tested. Power and speed specifications must be checked by the testing station.

The testing of a pre-production model tractor is permitted under special circumstances. If this is done, when the report is published, the testing station must certify in the report it has checked the series production conforms to the specification of the tested tractor.

The test report shall state how the tractor was selected.

2.1.2 Manufacturer's instructions

Once the test has started the tractor shall never be operated in a way that is not in accordance with the manufacturer's published instructions in the form of an operating handbook.

2.1.3 Retesting

A testing station will only retest a tractor model if it has been modified so that its performance may be affected in such a way the original noise test might no longer be valid (see 2.5 for extensions).

When a National Designated Authority submits a test report for a retested tractor it must point out and report the modifications which have justified the new test.

2.1.4 Running-in and preliminary adjustments

The tractor shall be new and run in by the manufacturer before the test, on his responsibility and in accordance with his usual instructions. The running-in shall be carried out in collaboration with the testing station.

If this procedure is impracticable due to the tractor being an imported model, the testing station may itself run in the tractor provided the authority of the manufacturer or his representative, who will remain responsible for the running-in, is obtained.

The adjustment of the carburettor or the injection pump and the setting of the governor shall conform to the specifications provided by the manufacturer.

The manufacturer may make adjustments in conformity with the specifications during the period prior to testing. These adjustments shall not be changed during the test.

2.1.5 Auxiliary equipment

For all tests, accessories such as the hydraulic lift pump or air compressor may be disconnected only if it is practicable for the operator to do so as normal practice in work, in accordance with the handbook and without using tools, except as otherwise specified for a particular test. If not, they should remain connected and operate at minimum load.

2.1.6 Operating conditions

No corrections shall be made to the test results for the atmospheric conditions or other factors. Atmospheric pressure shall not be less than 96.6 kPa. If this is not possible because of conditions of altitude, a modified injection pump setting may have to be used, details of which will be included in the report. The pressure will be noted in the report. Stable operating conditions must have been attained at each load setting before beginning test measurements.

2.1.7 Checking power and speed specifications

Speed specifications and the power in the range of speed between maximum power engine speed and no-load engine speed (high idle) must be checked as specified in Figure 5.1.

The governor control lever should be set fully open. Some engines develop maximum power at rated engine speed; other engines with very high torque backup ratio may reach their absolute maximum power at a speed below rated speed, as shown in Figure 5.1. In each case, the PTO power at rated engine speed shall be determined. The tractor shall operate for a period of 20 min subsequent to a sufficiently long warming-up period for the power to become stabilised. The power at rated engine speed shall be the average of at least five readings made during the twenty-minute period. The power and the engine speed shall be noted and the flow rate of the injection pump (dm^3/h) shall be measured. The measured no-load engine speed shall also be noted.

The power curve shall be checked and, if required, adjusted to ensure the governor is operating within the speed range specified by the manufacturer.

The tolerance for rated engine speed shall be $0 / + 50 \text{ min}^{-1}(\text{rev}/\text{min})$; the power measured at the same point should not vary from the one specified by the manufacturer by more than $\pm 5 \%$.

2.2 Test conditions

2.2.1 Measuring equipment

A precision quality sound level meter shall be used meeting the requirements of the International Electrotechnical Commission Standards IEC 60651:1979; Amd1:1993 (until 31 December 2003) or IEC 60651:1979; Amd1:1993; Amd2:2000. Measurement shall be carried out with a frequency weighting network in conformity with curve A and set to give slow response as is described in the IEC publication.

The equipment shall be calibrated frequently and, if possible, before each measuring session.

An adequate technical description of measuring equipment shall be given in the test report.

2.2.2 Conditions for measurement

2.2.2.1 Measurement will be made on the unballasted tractor, in a sufficiently silent and open zone. For example, this zone may be an open space and the last 20 metres next to the test track shall be practically level.

2.2.2.2 The surface of the track shall be of a kind that pneumatic tyres do not cause excessive noise. It shall be made of concrete, asphalt or similar material and shall not be covered with powdery snow, high grass, friable soil or cinders.

2.2.2.3 Measurements shall be made in fine weather with little or no wind, with ambient noise and noise of wind 10 decibels less than the noise to be measured. Any extraneous noise occurring during the reading, which is not connected to general sound level measurement, shall not be taken into consideration.

2.2.2.4 Drawbar load shall be applied to the tractor by a loading apparatus remotely positioned to eliminate interference with the sound field caused by the tractor.

2.2.2.5 When the tractor is fitted with a cab, all openings such as doors and windows shall be closed. The test may be repeated with them open provided this would not cause a hazard in normal use of the tractor. The windscreen must be in place, closed.

2.3 Measurement method

2.3.1 During measurement the microphone diaphragm shall be face forward. The microphone shall be placed so that its centre is 250 mm to the side of the median plane of the seat, on the side on which the higher noise level is encountered, and is 700 mm above and 10 mm forward of the seat index point.

2.3.2 The governor control lever shall be set fully open. Where measurements are made under load, starting with no load, the load applied shall be increased until the maximum sound level is found. After each increase of load, time will be allowed for the sound level to stabilise before taking the measurement. Load conditions must be such that the engine is under the control of the governor.

2.3.3 The nominal speed is defined as the travel speed of the tractor at the rated speed of the engine calculated with the dynamic radius index of the tyres.

2.4 Sound level test

Sound level measurements may be performed in accordance with “Under load” and/or “Without load” procedures.

General requirements: During all the tests at the drawbar, the governor control shall be set for maximum power. Tests shall not be made in gears in which the forward speed will then exceed the safety limits of testing equipment.

2.4.1 “Under load” procedure

2.4.1.1 Sound level measurements shall be made as follows:

2.4.1.1.1 At the drawbar pull giving the maximum sound level, in each forward gear, recording the corresponding engine speeds;

2.4.1.1.2 Without load at the drawbar, in the gear giving the nearest nominal forward speed to 7.5 km/h and in top gear, recording the corresponding engine speeds.

2.4.1.2 Results shall be given in dB(A) and reported as follows:

2.4.1.2.1 Maximum sound level in the loaded gear giving the nearest nominal speed to 7.5 km/h and also in any gear giving a sound level at least 1 dB(A) greater;

2.4.1.2.2 Sound level without load in the gear giving the nearest nominal forward speed to 7.5 km/h;

2.4.1.2.3 Maximum sound level without load in the gear giving the maximum forward speed.

2.4.2 “Without load” procedure

2.4.2.1 Sound level measurements shall be made as follows:

2.4.2.1.1 Without load at the drawbar, in the gear giving the nearest nominal forward speed to 7.5 km/h, recording the corresponding engine speeds.

2.4.2.2 Results shall be given in dB(A) and reported as follows:

2.4.2.2.1 Sound level without load in the gear giving the nearest nominal forward speed to 7.5 km/h.

2.4.3 Four-wheel drive tractor

2.4.3.1 In the case of measurements on a four-wheel drive tractor, the sound level shall be measured both with the front axle engaged and disengaged.

2.4.3.2 If there is a two-wheel drive version, and if the manufacturer so wishes, he can have only the four-wheel drive version tested and asks for an extension of validity of the measurements to the two-

wheel drive version. The sound level assigned to the two-wheel drive version will be the higher of the two measurements recorded with and without the front axle engaged.

2.4.4 Tractors with a reversible driver's position

If there is a reverse driving position, the noise test may be repeated in the reverse position, in accordance with present section 2.4, subject to the manufacturer's instructions for driving in the reverse position as stated in the handbook. The windscreen of the tractor with a reversible driving position continues to be the one defined in paragraph 2.2.2.5 and must be in place, closed.

2.4.5 Optional seats

For tractors that could be fitted with optional seats:

2.4.5.1 the microphone shall be set relative to a seat index point chosen from the range available for fitting to a tractor;

2.4.5.2 the results will also apply to any of the available seats which give microphone positions within a 50 mm radius sphere of this reference point;

2.4.5.3 if any seat gives a microphone position outside this sphere it must be dealt with separately.

2.5 *Extension to other models of tractors*

2.5.1 Administrative extension

If there are changes in the make or denomination of the tractor or protective structure tested or listed in the original test report, the testing station that has carried out the original test can issue an 'administrative extension report'. This extension report shall contain a reference to the original test report.

2.5.2 Technical extension²

When technical modifications occur on the tractor or the protective structure, the testing station that has carried out the original test can issue a "technical extension report" for other models of tractors provided that they comply with the conditions referred hereunder:

- these models are fitted with the same engine (same technical characteristics, same settings, same performances) – If the testing station check the power and speed specifications according to procedure described in paragraph 2.1.7; the tests results will be stated in the report;
- these models are fitted with the same exhaust system, or with an exhaust system giving the same sound level as the one fitted for the reference test (if the testing station has verified it in other Code 5 test reports already approved);
- these models are fitted with the same roll-over protective structure, if fitted (except for tractors fitted with roll bar without any roof) and of the same soundproofing devices, or with a modified roll-over protective structure giving the same sound level as the one fitted for the

² The technical extension reports of original tests based on the seat reference point (SRP) as reference point should be referred to the same point. The provisions in Annex I should be considered for the definition of the clearance zone.

reference test (if the modifications may not have influence on the tests results or if the testing station has verified it in other Code 5 test reports already approved);

- these models are fitted with the same transmission to driving wheels, or, if it is not the case and for the no-load test only, modifications to the transmission do not change the gear having the nominal speed nearest to 7,5 km/h;
- these models are fitted with seats having the same SIP as the one fitted for the reference test or having a SIP location giving a microphone position within a 50 mm radius sphere of the reference test microphone position.

Dimensions in mm

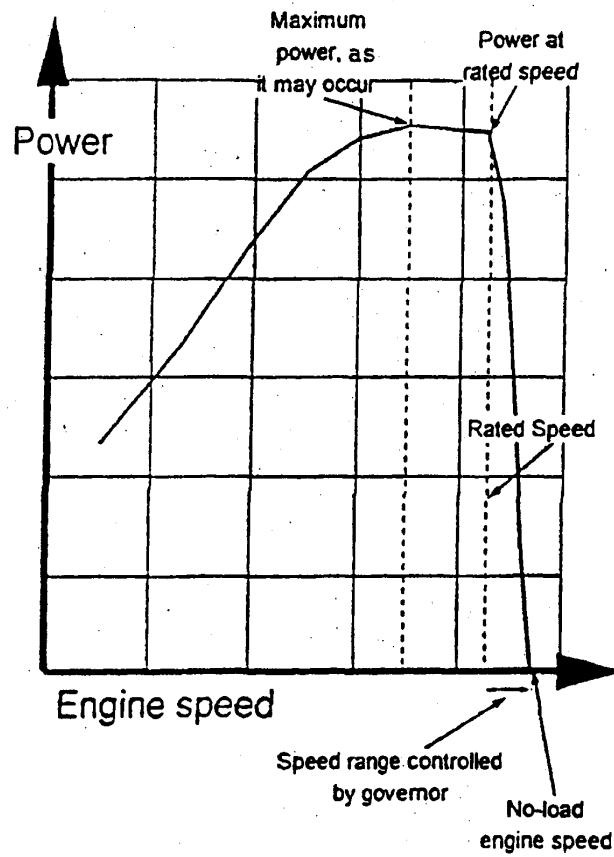

Figure 5.1

Checking power and speed specifications

SPECIMEN TEST REPORT

Note: Units shown below, which appear in ISO 1000:1992; Amd1:1998, shall be stated and followed by national units in parentheses, if necessary.

- Name and address of the tractor manufacturer:
- Name and address of manufacturer of protective structure:
- Submitted for test by:
- Selected for test by:

- Make of the protective structure:
- Model of the protective structure:
- Type of the protective structure: *Cab, Frame, Rear rollbar, Cab with integrated frame, etc.*

- Date, location of test and Code version used:
- Make/ model/ type of sound level meter:
- Type of track:

1. STRENGTH TEST REPORT REFERENCE

Either of the following statements shall appear as appropriate:

“The protective structure has not been approved in accordance with the OECD Standard Codes.”

or

“The protective structure has been approved in accordance with the OECD Standard Codes.” In this case paragraph 1.1 below must be filled.

1.1 Reference to the OECD test and approval (where applicable)

- Approval Number:
- Date of Approval:
- Location and country of test of the protective structure:

1.2 Reference mass, wheelbase and moment of inertia for calculating energies and crushing forces:

- Mass: kg
- Wheelbase: mm
- Moment of inertia: kgm²

2. SPECIFICATIONS OF TEST TRACTOR

2.1 Identification of tractor to which the protective structure is fitted for the test

- 2.1.1 - Make of the tractor: (*)
 - Model (trade name):
 - Type: 2 WD or 4 WD; rubber or steel tracks (if applicable);
 articulated 4 WD or articulated 4 WD with twin (dual) wheels (if applicable)

(*) possibly different from tractor manufacturer's name

- 2.1.2 Numbers
 - 1st Serial No. or prototype:
 - Serial No.:

- 2.1.3 Other specifications (*if applicable*)
 - Model denomination(s) for other countries:
 - Transmission type or gears x ranges:
 - Speed version: 30 or 40 km/h:
 - Manufacturer identification or Technical type number:

2.2 Mass of unballasted tractor with protective structure fitted and without driver

Front	kg
Rear	kg
Total	kg

2.3 Minimum track and tyre sizes

	Minimum track	Tyre sizes
Front	mm	
Rear	mm	

2.4 Tractor seat

- Tractor with a reversible driver's position (reversible seat and steering wheel): Yes / No
- Seat index point used for the test (this may differ from the actual SIP position of the seat fitted for the test, for purpose of accounting for the optional seats, see section 2.4.5 in the Code):
- Make/ model/ type of seat fitted for noise test and determination of the seat index point position:
- Make/ model/ type of optional seat(s) and seat index point position(s) (SIP):
 - (description of seat 1 and SIP position)
 - (description of seat 2 and SIP position)
 - (description of seat _ and SIP position)

2.5 Exhaust

- Make/ model/ type:
- Position of exhaust pipe:

2.6 Transmission

- Brief description of the transmission:

- Total ratios and travelling speeds

Gear No	Group or range	Number of engine revolutions for one revolution of the driving wheels	Nominal forward speed (*) at rated engine speed of min ⁻¹ (rev/min) km/h

(*) Calculated with a tyre dynamic radius index of mm (ISO 4251/1-2005)

2.7 Engine settings

	Setting	Checked
Setting of injection pump at rated engine speed and full load	dm ³ /h	dm ³ /h
P.t.o. power at rated engine speed	kW	kW
Corresponding engine speed	min ⁻¹ (rev/min)	min ⁻¹ (rev/min)
No-load engine speed	min ⁻¹ (rev/min)	min ⁻¹ (rev/min)

3. SPECIFICATIONS OF PROTECTIVE STRUCTURE

If the protective structure has not been OECD approved, then a complete description must be provided as outlined in paragraphs 2.1 to 2.7 of the specimen test reports in Codes 3, 4, 6, 7 or 8. In addition, the information requested in paragraphs 3.1 and 3.2 below must be provided.

If the protective structure has been OECD approved, then the information requested in paragraphs 3.1 and 3.2 below must be provided.

3.1 Brief description

Brief description of protective structure comprising:

- type of construction;
- details of mountings;
- details of cladding and padding;
- means of access and escape;
- additional frame:

Yes / No

3.2 Details of materials used for soundproofing the protective structure

3.2.1 Interior padding

- Roof: (material and sizes)
- Doors: (material and sizes)
- Floor: (material and sizes)

- Front panel: (material and sizes)
 - Rear panel: (material and sizes)
 - Side panels: (material and sizes)
 - Instrument panel and steering column (upper part): (material and sizes)
- 3.2.2 Glass: (parts - type - thickness)
- 3.2.3 Draught proofing: (material and sizes)
- 3.2.4 Heaters and ventilators: (make and type)
- 3.2.5 Windscreen wipers: (make and type)
- 3.2.6 Direction indicators: (make and type)

4. TEST RESULTS

Test results shall be presented as follows:

4.1 Results of sound level test - “Under load” procedure

Gear number	Drawbar Pull	Engine speed	Measured travelling speed	Number of driving wheels (2 and/or 4)	Sound level	Sound level extension to the 2 WD version
	kN	min ⁻¹ (rev/min)	km/h	n°	dB(A)	dB(A)
4.1.1 Test with the drawbar pull for which the tractor gives the maximum sound level [gear giving the nearest nominal forward speed to 7.5 km/h and also in any gear with a sound level increase of at least 1dB(A)] :						
4.1.1.1 All openings closed						
				2		
				4		
4.1.1.2 All openings open						
				2		
				4		
4.1.2 Unloaded test in the gear giving the forward speed nearest to 7.5 km/h:						
4.1.2.1 All openings closed						
				2		
				4		
4.1.2.2 All openings open						
				2		
				4		
4.1.3 Unloaded test in the gear giving the maximum forward speed:						
4.1.3.1 All openings closed						
				2		
				4		

4.1.3.2 All openings open					
				2	
				4	

4.2 Results of sound level test - “Without load” procedure

Gear number	Drawbar Pull	Engine speed	Measured travelling speed	Number of driving wheels (2 and/or 4)	Sound level	Sound level extension to the 2 WD version
	kN	min ⁻¹ (rev/min)	km/h	n°	dB(A)	dB(A)
4.2.1 Unloaded test in the gear giving the forward speed nearest to 7.5 km/h:						
4.2.1.1 All openings closed						
				2		
				4		
4.2.1.2 All openings open						
				2		
				4		

4.3 Remarks

4.4 Tractors to which test results are applicable

Tractor					ROPS			Differences with tested model ³
Make	Model	Type	WD	Other specifications, if necessary	Make	Model	Type	

³ And justification for the choice of extension procedure, if necessary

SPECIMEN TECHNICAL EXTENSION REPORT

Note: Units shown below, which appear in ISO 1000:1992; Amd1:1998, shall be stated and followed by national units in parentheses, if necessary.

- Name and address of the tractor manufacturer:
- Name and address of manufacturer of protective structure:
- Submitted for extension by:
- Selected for extension by:

- Make of the protective structure:
- Model of the protective structure:
- Type of the protective structure: *Cab, Frame, Rear rollbar, Cab with integrated frame, etc.*

- Date, location of extension and Code version used:

- Reference of the original test:
- Approval number and date of the original test report:

- Statement giving the reasons of the extension and explaining the procedure chosen (e.g. extension with validation test):

Depending on the case some of the following paragraphs may be omitted if their content is identical to the one of the original test report. It is only necessary to highlight the differences between the tractor and protective structure described in the original test report and the one for which the extension has been required.

1. STRENGTH TEST REPORT REFERENCE

Either of the following statements shall appear as appropriate:

“The protective structure has not been approved in accordance with the OECD Standard Codes.”

or

“The protective structure has been approved in accordance with the OECD Standard Codes.” In this case paragraph 1.1 below must be filled.

1.1 Reference to the OECD test and approval (where applicable)

- Approval Number:
- Date of Approval:
- Location and country of test of the protective structure:

1.2 Reference mass, wheelbase and moment of inertia

for calculating energies and crushing forces:

- Mass: kg
- Wheelbase: mm
- Moment of inertia: kgm²

2. SPECIFICATIONS OF TEST TRACTOR

2.1 Identification of tractor to which the protective structure is fitted for the test

- 2.1.1 - Make of the tractor: (*)
 - Model (trade name):
 - Type: 2 WD or 4 WD; rubber or steel tracks (if applicable);
 articulated 4 WD or articulated 4 WD with twin (dual) wheels (if applicable)
 (*) possibly different from tractor manufacturer's name

- 2.1.2 Numbers
 - 1st Serial No. or prototype:
 - Serial No.:

- 2.1.3 Other specifications (if applicable)
 - Model denomination(s) for other countries:
 - Transmission type or gears x ranges:
 - Speed version: 30 or 40 km/h:
 - Manufacturer identification or Technical type number:

2.2 Mass of unballasted tractor with protective structure fitted and without driver

Front	kg
Rear	kg
Total	kg

2.3 Minimum track and tyre sizes

	Minimum track	Tyre sizes
Front	mm	
Rear	mm	

2.4 Tractor seat

- Tractor with a reversible driver's position (reversible seat and steering wheel): Yes / No
- Seat index point used for the test (this may differ from the actual SIP position of the seat fitted for the test, for purpose of accounting for the optional seats, see section 2.4.5 in the Code):
- Make/ model/ type of seat fitted for noise test and determination of the seat index point position:
- Make/ model/ type of optional seat(s) and seat index point position(s):
 (description of seat 1 and SIP position)
 (description of seat 2 and SIP position)
 (description of seat and SIP position)

2.5 Exhaust

- Make/ model/ type:
- Position of exhaust pipe:

2.6 Transmission

- Brief description of the transmission:

- Total ratios and travelling speeds

Gear No	Group or range	Number of engine revolutions for one revolution of the driving wheels	Nominal forward speed (*) at rated engine speed of min ⁻¹ (rev/min) km/h

(*) Calculated with a tyre dynamic radius index of mm (ISO 4251/1-2005)

2.7 Engine settings

	Setting	Checked
Setting of injection pump at rated engine speed and full load	dm ³ /h	dm ³ /h
P.t.o. power at rated engine speed	kW	kW
Corresponding engine speed	min ⁻¹ (rev/min)	min ⁻¹ (rev/min)
No-load engine speed	min ⁻¹ (rev/min)	min ⁻¹ (rev/min)

3. SPECIFICATIONS OF PROTECTIVE STRUCTURE

If the protective structure has not been OECD approved, then a complete description must be provided as outlined in paragraphs 2.1 to 2.7 of the specimen test reports in Codes 3, 4, 6, 7 or 8. In addition, the information requested in paragraphs 3.1 and 3.2 below must be provided.

If the protective structure has been OECD approved, then the information requested in paragraphs 3.1 and 3.2 below must be provided.

3.1 Brief description

Brief description of protective structure comprising:

- type of construction;
- details of mountings;
- details of cladding and padding;
- means of access and escape;
- additional frame:

Yes / No

3.2 Details of materials used for soundproofing the protective structure

3.2.1 Interior padding

- Roof: (material and sizes)
- Doors: (material and sizes)
- Floor: (material and sizes)
- Front panel: (material and sizes)
- Rear panel: (material and sizes)
- Side panels: (material and sizes)
- Instrument panel and steering column (upper part): (material and sizes)

3.2.2 Glass: (parts - type - thickness)

3.2.3 Draught proofing: (material and sizes)

3.2.4 Heaters and ventilators: (make and type)

3.2.5 Windscreen wipers: (make and type)

3.2.6 Direction indicators: (make and type)

4. CONCLUSION

Statement:

The difference between the original tested model and the models for which the extension has been required are:

- ...
- ...

The test station has checked the modifications and certifies that the effect of these modifications does not affect the results of the noise measured at the driving position which are the following.

Test results

Test results shall be presented as follows:

4.1 Results of sound level test - “Under load” procedure

Gear number	Drawbar Pull	Engine speed	Measured travelling speed	Number of driving wheels (2 and/or 4)	Sound level	Sound level extension to the 2 WD version
	kN	min ⁻¹ (rev/min)	km/h	n°	dB(A)	dB(A)
4.1.1 Test with the drawbar pull for which the tractor gives the maximum sound level [gear giving the nearest nominal forward speed to 7.5 km/h and also in any gear with a sound level increase of at least 1dB(A)] :						
4.1.1.1 All openings closed						
				2		
				4		
4.1.1.2 All openings open						
				2		
				4		
4.1.2 Unloaded test in the gear giving the forward speed nearest to 7.5 km/h:						
4.1.2.1 All openings closed						
				2		
				4		
4.1.2.2 All openings open						
				2		
				4		
4.1.3 Unloaded test in the gear giving the maximum forward speed:						
4.1.3.1 All openings closed						
				2		
				4		
4.1.3.2 All openings open						
				2		
				4		

4.2 Results of sound level test - “Without load” procedure

Gear number	Drawbar Pull	Engine speed	Measured travelling speed	Number of driving wheels (2 and/or 4)	Sound level	Sound level extension to the 2 WD version
	kN	min ⁻¹ (rev/min)	km/h	n°	dB(A)	dB(A)
4.2.1 Unloaded test in the gear giving the forward speed nearest to 7.5 km/h:						
4.2.1.1 All openings closed						
				2		
				4		
4.2.1.2 All openings open						
				2		
				4		

4.3 Remarks

4.4 Tractors to which test results are applicable

Tractor					ROPS			Differences with tested model ⁴
Make	Model	Type	WD	Other specifications, if necessary	Make	Model	Type	

⁴ And justification for the choice of extension procedure, if necessary.

ADMINISTRATIVE EXTENSION REPORT

Note: Units shown below, which appear in ISO 1000:1992; Amd1:1998, shall be stated and followed by national units in parentheses, if necessary.

- Name and address of the tractor manufacturer:
- Name and address of manufacturer of protective structure:
- Submitted for extension by:

- Make of the protective structure:
- Model of the protective structure:
- Type of the protective structure: *Cab, Frame, Rear rollbar, Cab with integrated frame, etc.*

- Date, location of extension and Code version used:

- Reference of the original test:
- Approval number and date of the original test report:

- Statement giving the reason of the extension and explaining the procedure chosen:

1. SPECIFICATION OF PROTECTIVE STRUCTURE

- Frame or Cab:
- Manufacturer:
- Make:
- Model:
- Type:
- Serial Number from which modification applies:

2. SPECIFICATION OF TRACTOR

- Make of the tractor: (*)
 - Model (trade name):
 - Type: 2 WD or 4 WD; rubber or steel tracks (if applicable);
articulated 4 WD or articulated 4 WD with twin (dual) wheels (if applicable)
- (*) possibly different from tractor manufacturer's name

3. DETAILS OF MODIFICATIONS

Since the original test report, the following modifications have been made:

4. STATEMENT

The modifications do not affect the results of the original test.

The original test report therefore applies.

ANNEX 1

**CLEARANCE ZONE REFERRED TO
THE SEAT REFERENCE POINT**

INTRODUCTION

The paragraphs considered in the Annex refer to the definitions of the seat reference point (SRP) and the location of the microphone for the noise measurement. The numbering of the paragraphs is the same of the corresponding paragraphs in the main Code.

In the case of extension reports to test reports that originally used SRP, required measurements shall be made with reference to SRP instead of SIP. Moreover, the use of SRP shall be clearly indicated. For drafting such extension reports, the paragraphs detailed in the Annex should be followed. For the paragraphs non-reported in the Annex, previous version of Code 5 should be considered.

1. DEFINITIONS

1.3 *Determination of seat reference point; Seat location and adjustment for test*

1.3.1 Seat reference point

1.3.1.1 The reference must be established by means of the apparatus illustrated in Figures 5.2, 5.3 and 5.4. The apparatus consists of a seat pan board and backrest boards. The lower backrest board is jointed in the region of the ischium humps (A) and loin (B), the joint (B) being adjustable in height.

1.3.1.2 The seat reference point is defined as the point in the median longitudinal plane of the seat where the tangential plane of the lower backrest and a horizontal plane intersect. This horizontal plane cuts the lower surface of the seat pan board 150 mm in front of the above-mentioned tangent.

1.3.1.3 The apparatus is positioned on the seat. It is then loaded with a force of 550 N at a point 50 mm in front of joint (A), and the two parts of the backrest board lightly pressed tangentially against the backrest.

1.3.1.4 If it is not possible to determine definite tangents to each area of the backrest (above and below the lumbar region), the following steps must be taken:

- where no definite tangent to the lower area is possible, the lower part of the backrest board is pressed against the backrest vertically;
- where no definite tangent to the upper area is possible, the point (B) is fixed at a height of 230 mm above the lower surface of the seat pan board, the backrest board being perpendicular to the seat pan board. Then the two parts of the backrest board are lightly pressed against the backrest tangentially.

1.3.2 Seat location and adjustment for test

1.3.2.1 Where the seat position is adjustable, the seat should be set at, or as near as possible to, the midpoint of its horizontal and vertical adjustment;

1.3.2.2 any suspension of the seat shall be depressed until the seat reaches the midpoint of its dynamic range;

1.3.2.3 where the position of the seat is adjustable only lengthwise and vertically, the longitudinal axis passing through the seat reference point shall be parallel with the vertical longitudinal plane of the tractor passing through the centre of the steering wheel and not more than 100 mm from that plane.

2. RULES AND DIRECTIONS

2.3 *Measurement method*

2.3.1 During measurement, the microphone diaphragm shall be facing forward. The microphone shall be placed so that its centre is 250 mm to the side of the median plane of the seat, on the side on which the higher noise level is encountered, and is 790 mm above and 150 mm forward of the seat reference point.

Dimensions in mm

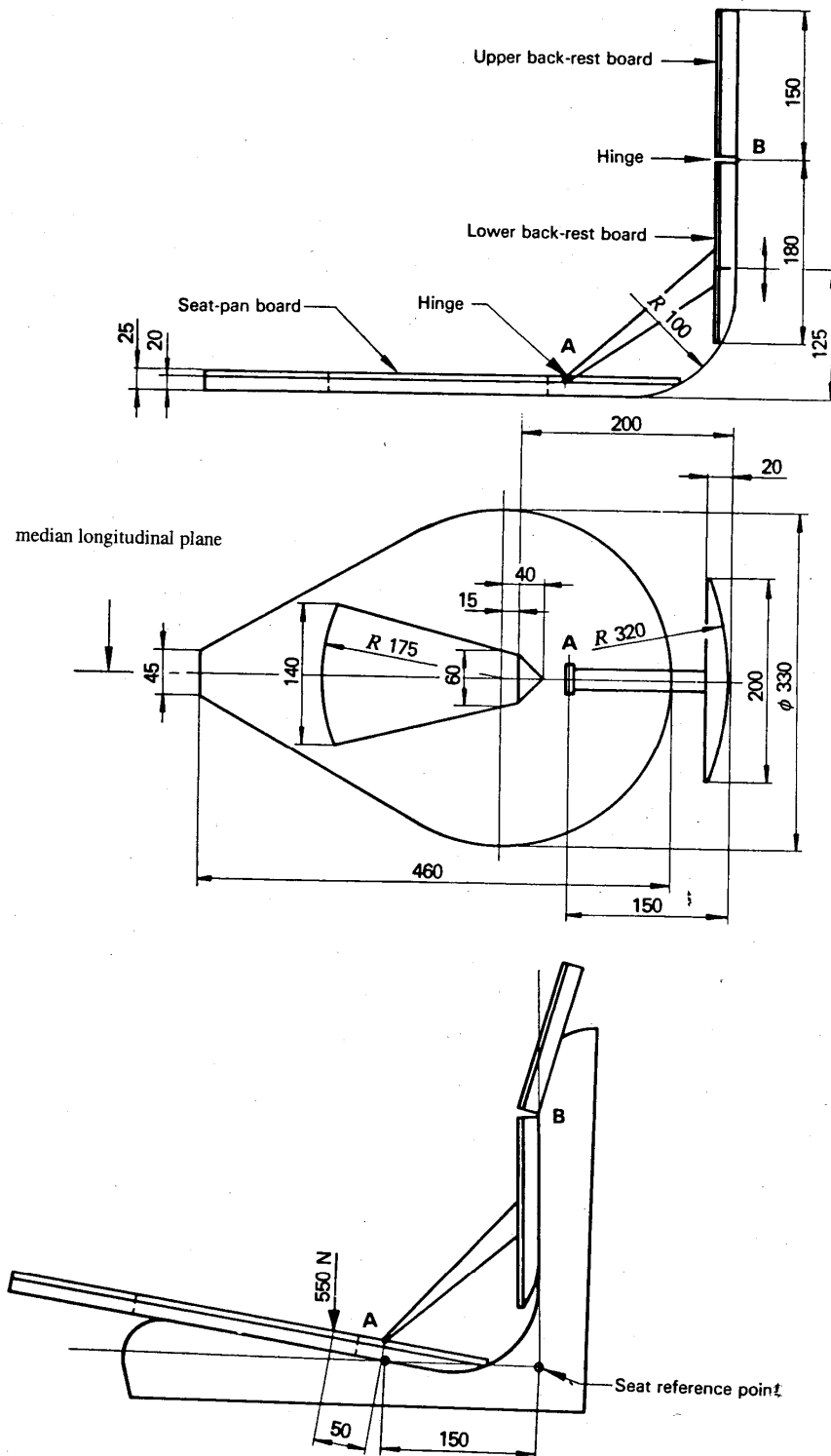

Figures 5.2, 5.3 and 5.4
Apparatus for determination of seat reference point